

Important measurement data  
just a click away!

## With the most flexible continuous Monitoring System



Overview 2

Software 6

Datacenter 10

Alarming 11

Hardware 13

Data security 14

Services 16

Contract Modules 19

## RMS – ROTRONIC MONITORING SYSTEM

The Rotronic continuous Monitoring System allows users to monitor anything from anywhere using an on-premise or cloud (SaaS) solution.

### Strongly regulated applications

- Fridges
- Cold rooms
- Freezers
- Transport with dry ice
- Cryogenics with nitrogen tanks
- Blood banks
- Clean rooms
- Warehouses

### Less regulated applications such as:

- Museums
- Archives
- Storage areas
- And much more...

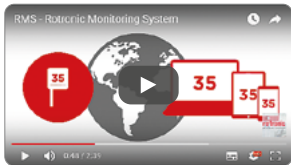

Watch the short Explain-it Movie

### Customize your own RMS Architecture

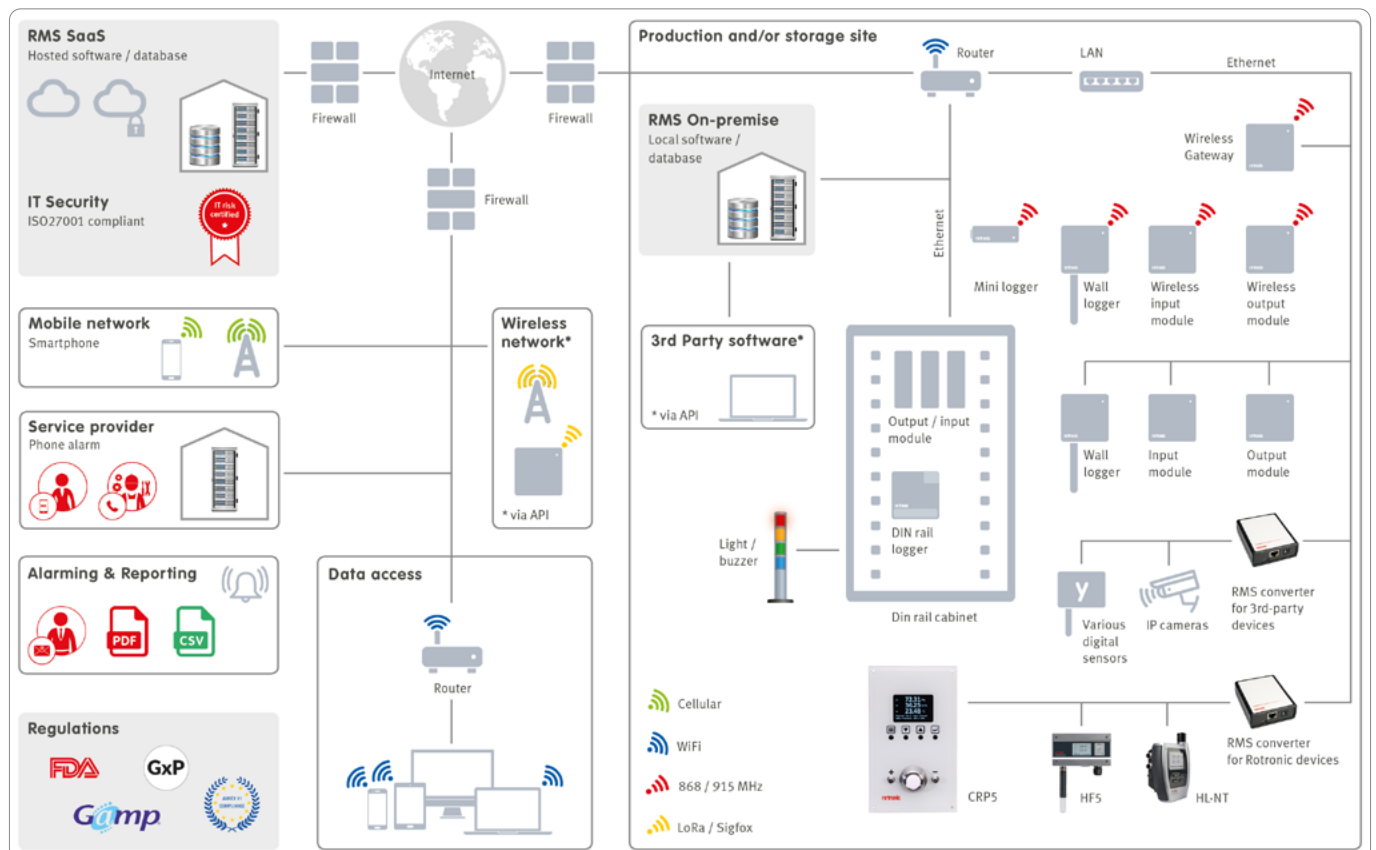

## Multiple parameter monitoring

RMS monitors various parameters to ensure that the environment meets the required specifications for any application.

1. Digital probes give access to a complete audit trail and easy digital calibration thanks to the probe hot swap possibility:

- Relative humidity
- Temperature
- Differential pressure



2. Rotronic offers range of analog probes that can be integrated into the monitoring system:

- NTC temperature probes
- Pt100 temperature probes
- CO<sub>2</sub> probes for incubators (0...20%)



3. Other inputs and outputs for third party devices (particle counters, air flow and other such parameters):

- 0/4...20mA for the integration of existing devices or other parameters
- 0...10V for the integration of existing devices or other parameters
- Digital inputs for door contacts, leak detectors, etc.
- Digital outputs to switch alarm beacons
  - Webcams to enable a snap shot to add to automatically generated reports and see the application in real time (mouse-over)

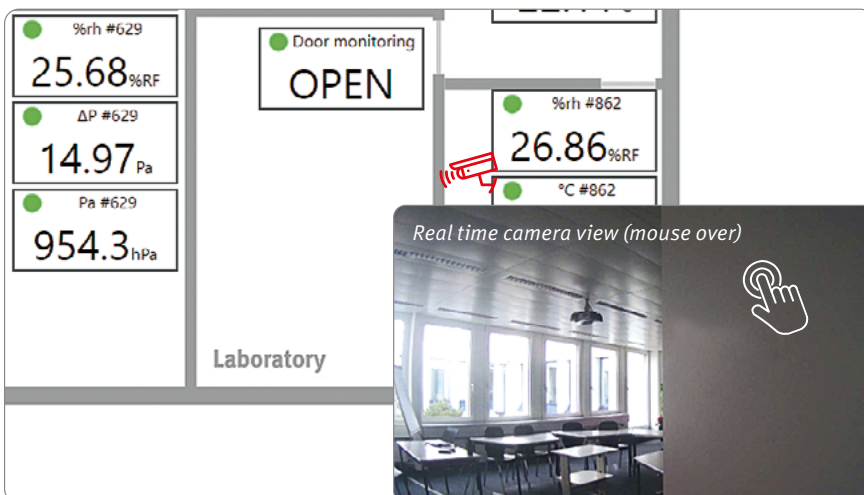

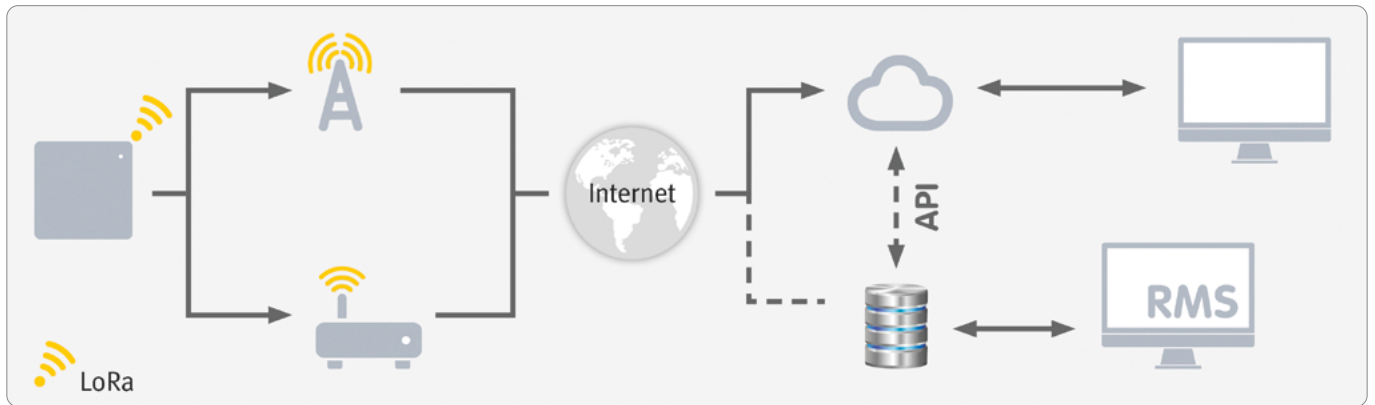

Example: LoRa-Geräte über die API-Funktion.

4. The integration of 3rd party digital devices is possible via multiple methods:
  - MODBUS TCP: If the MODBUS map is available, then it is possible to integrate most MODBUS TCP devices.
  - API: The RMS software has an API function to integrate data from 3rd party devices.
5. Data collected with RMS can be extracted via multiple methods:
  - Via the RMS interface, extract selected data via .pdf, .csv or JSON.
  - Automated reporting is available for .pdf documents.
  - With the API, data can be exported via JSON.
  - The RMS-WEB-OPC Server application can be used to send data to an OPC client.

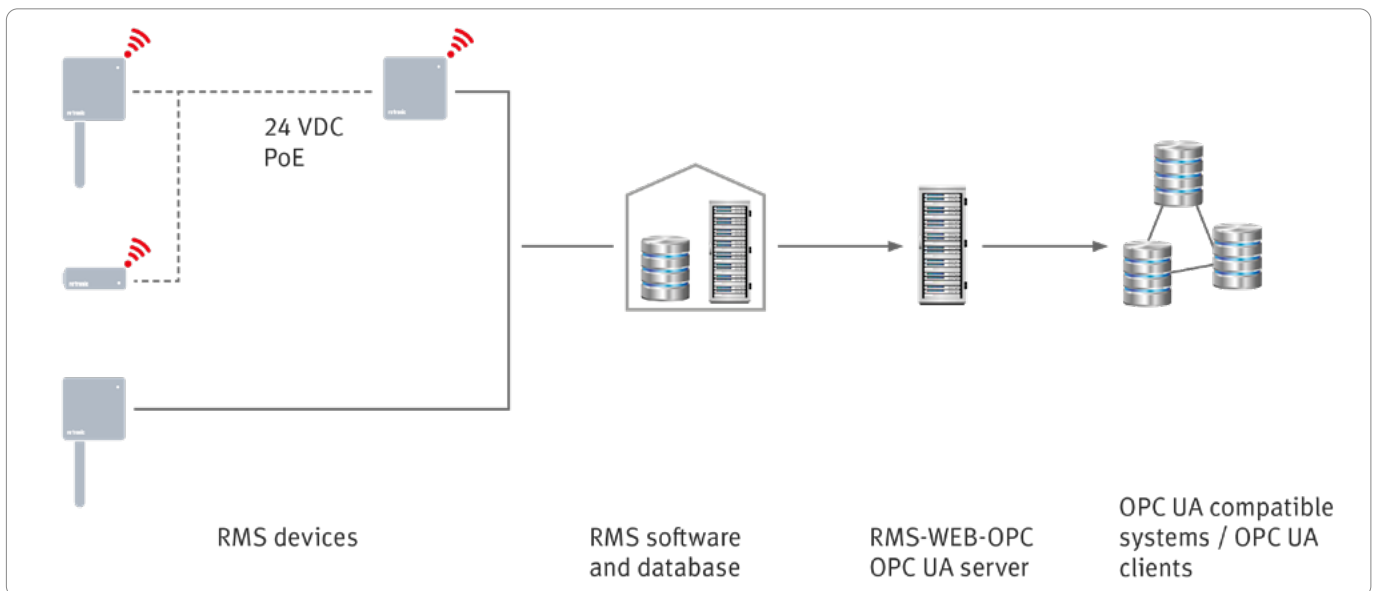

## Wireless or wired secure data communication

### 1. Wireless:

- Data stored on the logger with a battery backup and 24V power supply
- Redundant or parallel operation with various gateways
- Decrease wiring costs
- No more looking for errors in cabling
- Projects accomplished faster due to no cable requirements
- Easy to relocated physical measuring points
- Fast and easy implementation of new measuring points
- Monitor mobile equipment
- 868 or 915 MHz

### 2. Wired:

- Data stored on the logger with a backup battery, PoE and 24V power supply
- No loss of communication for high risk applications
- Link up to the existing Ethernet network

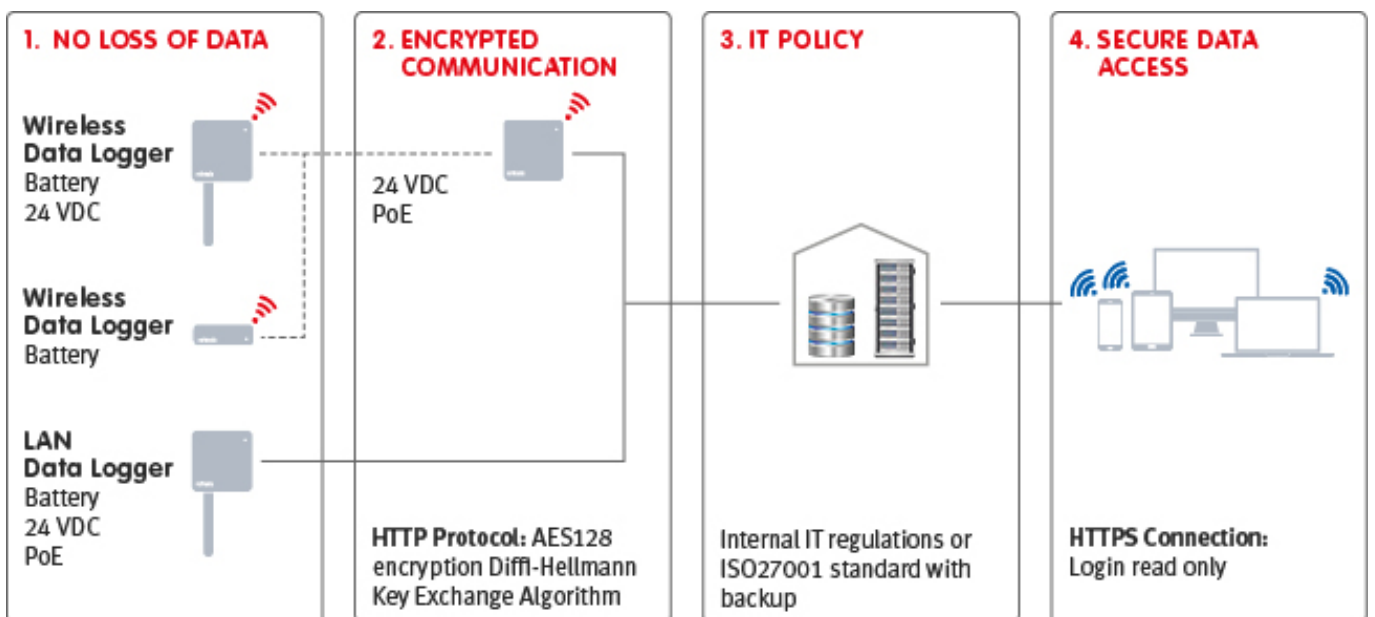
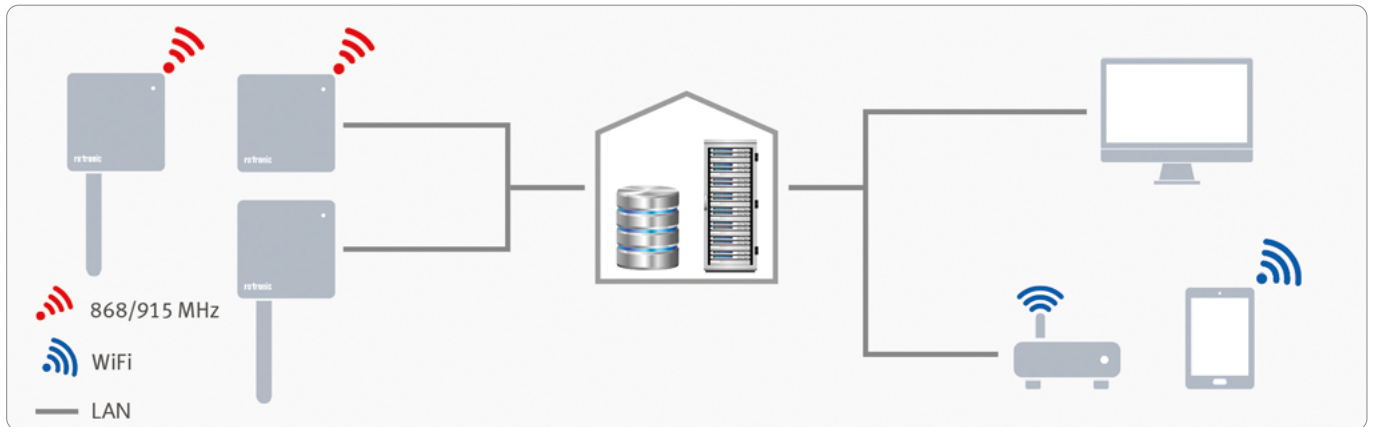

**Compliance**

1. Validatable software
2. FDA CFR 21 Part 11 compliant
3. EU 11 compliant
4. Developed based upon the GAMP®5 recommendations
5. Complete GxP documentation (from the URS to the IQ / OQ / PQ)



**Real time monitoring and alarming**

The RMS software will inform you in real time via E-Mail, SMS and telephone call should a measurement point be out of limits! Automatic reporting allow for a hassle free solution and a quick login via mobile phone, tablet, PC or laptop will give you either a chart, table or a layout overview of the current situation, with short cuts to all events listed within the audit trail.

Find out more at [www.rotronic.com/rms](http://www.rotronic.com/rms)

**MONITORING SOFTWARE**



**Main Software Features**

- Alarm overview – see directly how many alarms are active and where they are coming from
- Receive alerts via interactive phone, SMS’s and E-Mails
- Audit trail to see exactly what happened and when
- Monitor multiple locations – one system for all your monitoring locations
- Input floor plans – get a real overview of the setup

- Scalable – perfect for single points in small installations to thousands of points in worldwide installations
- Automatic report generation
- Integration of Rotronic and any third party hardware – analog and digital
- Automatic validation scripts – for fast and effective OQ validation
- Continuously developing based around customer feedback
- Create custom dashboards per user
- FDA 21 CFR Part 11 & EU 11 complaint
- GAMP<sup>®</sup>5 conform for GxP applications

**Additional Features**

- Calibrate all of your measuring points, possibility to adjust all of the Rotronic devices
- Archive all measuring points that are no longer needed, keeping access to the data for as long as necessary
- Save all your documents in the system: user manuals, data sheets, calibration certificates, SOP’s...

**Main software benefits**

- Compliance, audit and risk management
- Time saving with automatic data collection and report generation
- 24/7 real-time centralised monitoring of all operations
- All critical measurements in one system
- Real time alarming for critical measuring points

**Software solutions**



**1. Fast & Easy with the Rotronic SaaS Cloud solution**

Forget the hassle of having to maintain your IT infrastructure and focus only on what is crucial to your application. You can setup multiple measurement points in various locations and access the data from any device with a browser and internet connection. Setup alarms and notifications to be sure that you are always informed of what is happening!



**2. Remain compliant to GxP regulations with the Rotronic Exclusive SaaS Cloud solution**

Hosted on a high security and redundant datacentre with your own virtual server, you can run the Rotronic category 4 software in the cloud throughout each and every GxP compliant facility. Equip your worldwide facilities with the RMS hardware and access all of the data, including the audit trail, alarming and data analysis functions from a completely validated system.



**3. Take advantage of your own IT infrastructure with the RMS on-premise solution**

Run the RMS software with an SQL database on your own IT infrastructure and have complete control over your entire system and comply to your own internal regulations, access the interface via most browsers.

## System Overview

RMS offers different views/tabs to present your system data, customised to your needs.

- **Chart** – measured values graphically and numerically and direct notification status
- **Table** – measured values numerically and various other data
- **Layout** – measured values numerically with placement in a room layout
- **Dashboard** – individual dashboard for each and every user
- **Events** – audit logs, alarms, warnings and system messages

### Chart view

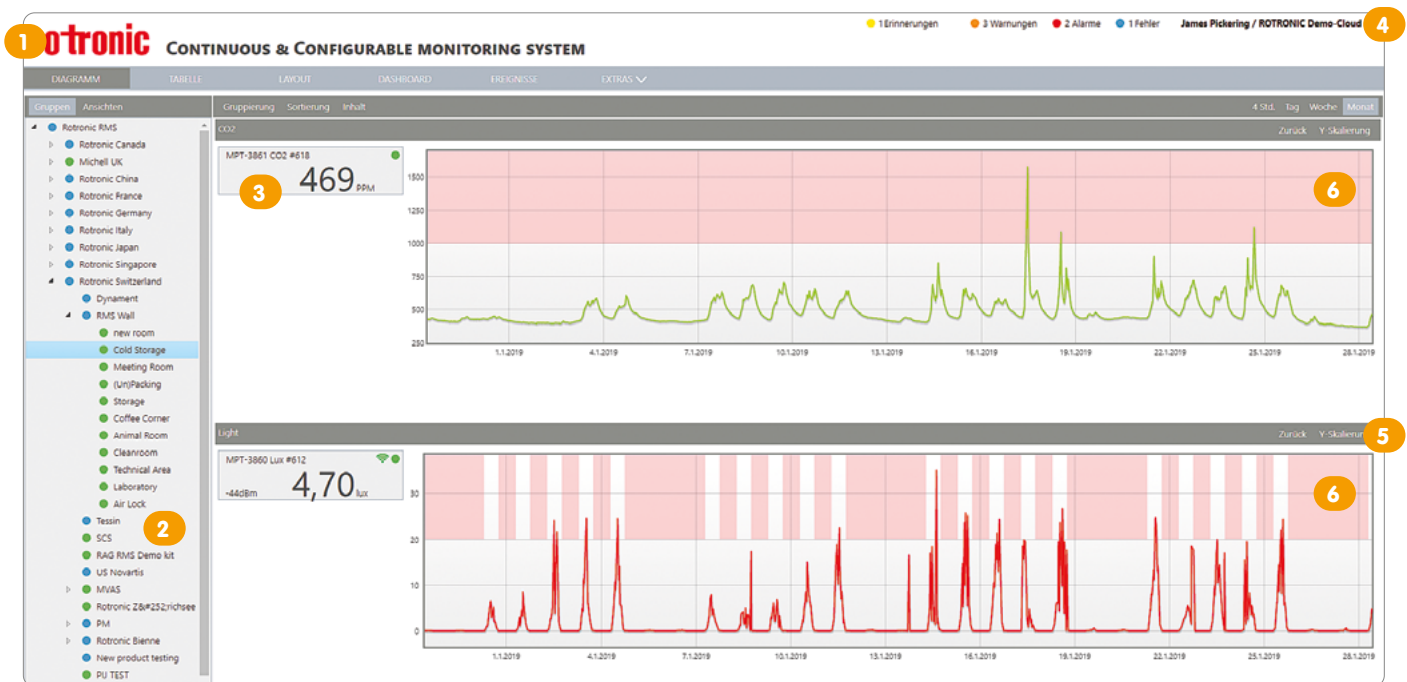

- 1 Upload your company logo
- 2 Group information by location, room...
- 3 Real-time measurement value and live status
- 4 Current logged on user, and notification overview
- 5 Historical overview
- 6 Alarms bands for a visual depiction of warnings and alarms



## DATACENTER



### RMS Database Security

When purchasing the RMS SaaS solution, Rotronic works together with the company 4Net. They provide a virtual data centre for the Rotronic Monitoring System server and database. 4Net uses the Interxion data centre. Interxion’s Zurich data centre provides an ultra-secure, known location for storing and processing data in line with Swiss data protection regulations. Like all Interxion data centres, Zurich operates in full accordance with the ITILv3 framework and has ISO 27001 and ISO 22301 certification. Their compliance with the FINMA circular 07/8 is externally audited.

#### Operational excellence:

- 99.999% availability SLA
- 2N or N+1 configurations for all critical systems
- 24x7 operation and monitoring

#### Sustainability:

- 100% renewable energy
- Carbon neutral, certified by myclimate®

#### Security:

- Monitored 24x7 by CCTV and security patrols

#### Resilience and business continuity:

- 24x7 monitoring and alarms for every critical system
- Connectivity: quadruple-entry fibre from separate carrier main routes and rapidly installed cross connects
- Power: secured grid supply from two sub-stations from two different power providers, two power feeds for all equipment, each independently equipped with a power supply and generator backup with full load capacity for indefinite running
- Environment: SLAs on temperature and humidity in line with ASHRAE recommendations, N+1 cooling, sophisticated water and very early smoke detection systems, Inergen® gas fire suppression in line with local regulations and designed for maximum safety and minimum damage
- Backups saved in a second data centre also located in Switzerland but 80 km away from the main one

# ALARMING



Rotronic Monitoring System alarm protocols were set up to ensure that critical alarms cannot be missed. Notifications can be triggered based upon the risk level.

Four levels of alarming are available, activation is based on the defined risk:

- Reminder for events that are non-urgent:
  - Low battery (device)
  - Simulator connected (measuring point)
  - Reminder that a calibration is due
  - Data gap after downloading missing measured values
- Warning for measured values that are out of limit (measuring point)
- Alarming for measured values that are out of limit (measuring point)
- Error for urgent hardware errors:
  - Device timeout (device)
  - Sensor error (measuring point)

An overview of the alarms can be seen once the user has logged into the system. The user only sees the alarms relevant to his granted access rights. Each measuring point, if not conforming, will be attributed a different colour based upon the alarm status:



Critical alarms can also be set up with a warning before alarms are activated. Hysteresis and a delay can be set up for the warning, with upper and lower limits defined, as well as for the alarming.

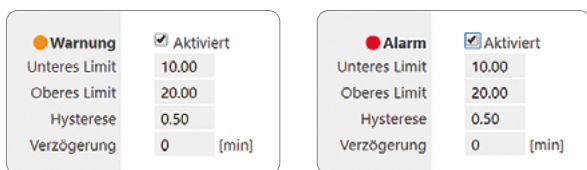

All alarms are clearly shown in the audit trail indicating the unique ID for the event, the time and date of the alarm, information about what the alarm is, the target (the measuring point or device) as well as additional details.

Viewing the audit trail, it is easily possible to see if an alarm has been either acknowledged, or if it has ended. If an alarm is acknowledged, the time, date, name of the user who acknowledged the alarm as well as the alarm details are also saved and visible within the audit trail. Within the audit trail, it is also possible to close or inhibit an alarm.

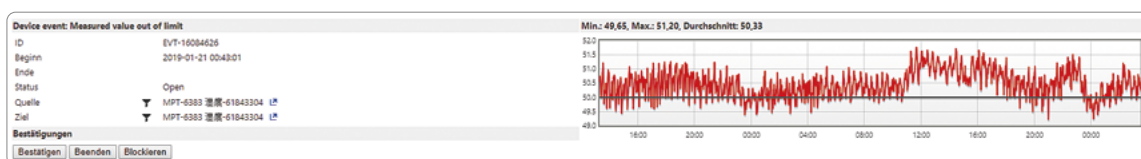

Alarms can be set up based upon either the measuring point, or via an alarm scheme. For alarms based upon the measuring point the choice of options is limited. Within an alarm scheme the user has the possibility to set a condition such as an active time as well as a warning. An action can be configured in both situations.

The various alarms can be notified in different ways and can be sent to just one or multiple users.

- E-Mail
- SMS \*
- Telephone call \*
- Switch relay
- Send data via TCP

\* The user's telephone number must be added to the system.

**E-Mail alarm:** When setting the system up with a TCP/IP based camera, a snap-shot can be added to the E-Mail with a chart (either as a PDF or included in the body of the E-Mail).

**SMS alarm:** The alarm will be sent out in the language in which the software is configured.

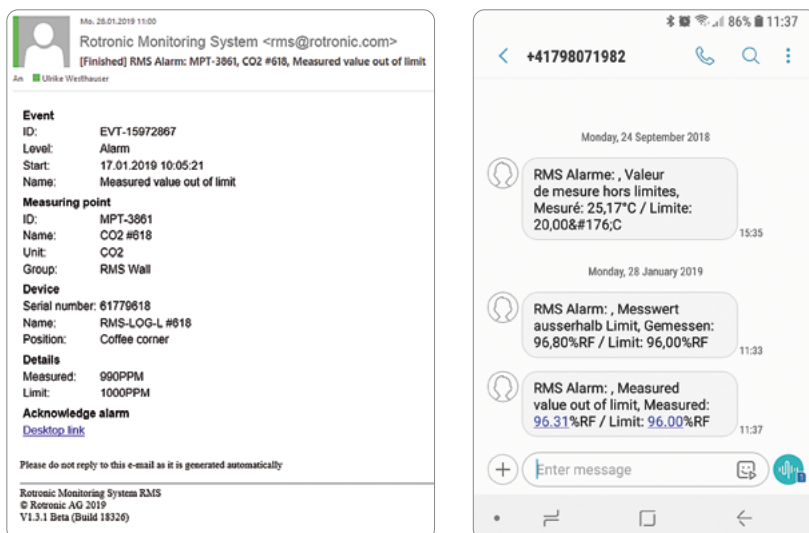

**Telephone call:** Within the system settings, the user can decide the information stated during the telephone call, from the device/measuring point ID to a measuring point comment. For the telephone call, if various users are selected, the system will call the first user on the list and continue through the list. Only when one user inhibits the alarm via the telephone will calling stop. The inhibition time from the telephone call is also set up within the system settings.

**Switch relay:** If a device with a relay is included in the system, then with the alarm scheme, it is possible to trigger that alarm to action either a visual or audible alarm, or another type.

**Send data via TCP:** Data can be transmitted to a TCP/IP device to switch a device to either On or Off.

It is also possible to set up IF-THEN scripts to trigger actions on the basis of one or more defined pre-conditions.

# HARDWARE

## Lan and Wireless System

All RMS components are connected via a LAN or a wireless interface. All data is transmitted to the SQL database and visualised via a web browser.



### RMS Wall module

The RMS wall module is designed for applications where the module is visible to users: simple and practical. The module can be fixed to the wall and easily wiped clean. The RMS Wall module is available with either a LAN or a wireless (868 or 915MHz) interface. The module can be powered either via PoE (LAN version only), 24V or battery and can store 44'000 data points.



#### Wall module devices:

- RMS-LOG-L / 868 / 915
- RMS-GW-868 / 915
- RMS-LOG-T30-L / 868 / 915



The RMS Wall module also exists with display.

#### Wall module with display devices:

- RMS-D-L
- RMS-LOG-L-D



### The RMS Mini module

The RMS Mini module is only available with a wireless interface (868 or 915MHz) and battery powered, with a storage of up to 12'000\* data points.

#### Mini module devices:

- RMS-MLOG-T-868 / 915
- RMS-MLOG-T10-868 / 915
- RMS-MDI-868
- RMS-MLOG-B-868 / 915
- RMS-MADC-868-A / 915-A



- RMS-MADC-868-V
- RMS-MLOG-LGT-868

### RMS Din Rail module

The RMS Din Rail module is for installation where esthetics are not crucial to the application. The RMS Din Rail module is available with either a LAN or a wireless (868 or 915MHz) interface. The module can be powered either via PoE (LAN version only), 24V or battery and can store 44'000 data points.

#### Din Rail module devices:

- RMS-DI-L-R
- RMS-DO-L-R
- RMS-ADC-L-R



### RMS Converter

The RMS Converter allows for integration of digital third party devices with an Ethernet connection. The converter will translate the digital protocol and send it to the database, the values are then visible via the web browser. The converter also has an onboard 7 day memory\*\* should the network go down. The device is limited to 100 devices.

#### RMS converter:

- RMS-CONVERTER-100

\* Please check each device individually for the data storage possibilities.

\*\* The converter should be on the same network as the third party device.

## DATA SECURITY / -INTEGRITY / FDA CONFORMITY

**Data security, data integrity, data availability: these three terms play a central role in monitoring systems. The RMS reassuringly scores in all these fields.**



### Data Security

Data security means the data cannot be accessed by unauthorized persons. This is achieved through encryption during data transfer and storage.

### Data Security in RMS

The monitoring system provides encryption of the data during transfer. This means the data can neither be tapped or manipulated by so-called retry attacks. The security of the stored database in RMS is ensured by the IT structure. The Rotronic Cloud is protected by certified IT data centers. If the database is located in the customer’s server center, the customer defines the security infrastructure. Rotronic then offers IT support.

### FDA/GMP Requirements

Regulators in the pharmaceutical and food industries demand that all relevant events are recorded so they are traceable. This is achieved through the electronic marking of all calibration measurements and verification processes. The so-called “electronic recording” requires unique identification of certificates. This means that every calibration certificate with a date and inspection stamp must be traceable such that the calibration chain can be verified.

### Audit Trail

When a monitoring system is commissioned, it is calibrated and validated. In this way the operator assures his Quality department that the system works correctly. During subsequent operation, all relevant changes must be recorded in full. The audit trail guarantees recording of all changes in the system such as, for example, change in measurement probes, user activities, battery change. This in turn ensures that all events can be tracked at a later date.

### Data Availability

For some manufacturer’s systems, data availability can contradict data security because secure data are difficult to access. The user must authenticate themselves and use secure connections or verified platforms. Nevertheless, the trend is clearly moving towards worldwide data accessibility allowing platform-independent viewing and evaluation.

### Data Integrity

Ensuring data integrity means guaranteeing secure transmission and storage. A measured value must not change during transmission because of disruptions. Data transmission and storage must therefore be safe from manipulation. This is achieved with CRC checksums and intermediate storage during data transmission. In this way, faulty data communication is recognized and the data stored in the buffer memory are sent again until the transmission has been finished.

All data in RMS are sent with CRC checksums and confirmed by the recipient after receipt. Faulty data transmission is thus ruled out. Should the data not arrive with the recipient, they are stored intermediately by the logger and can then be transmitted at a later point in time when the connection has been restored.

### RMS Communications

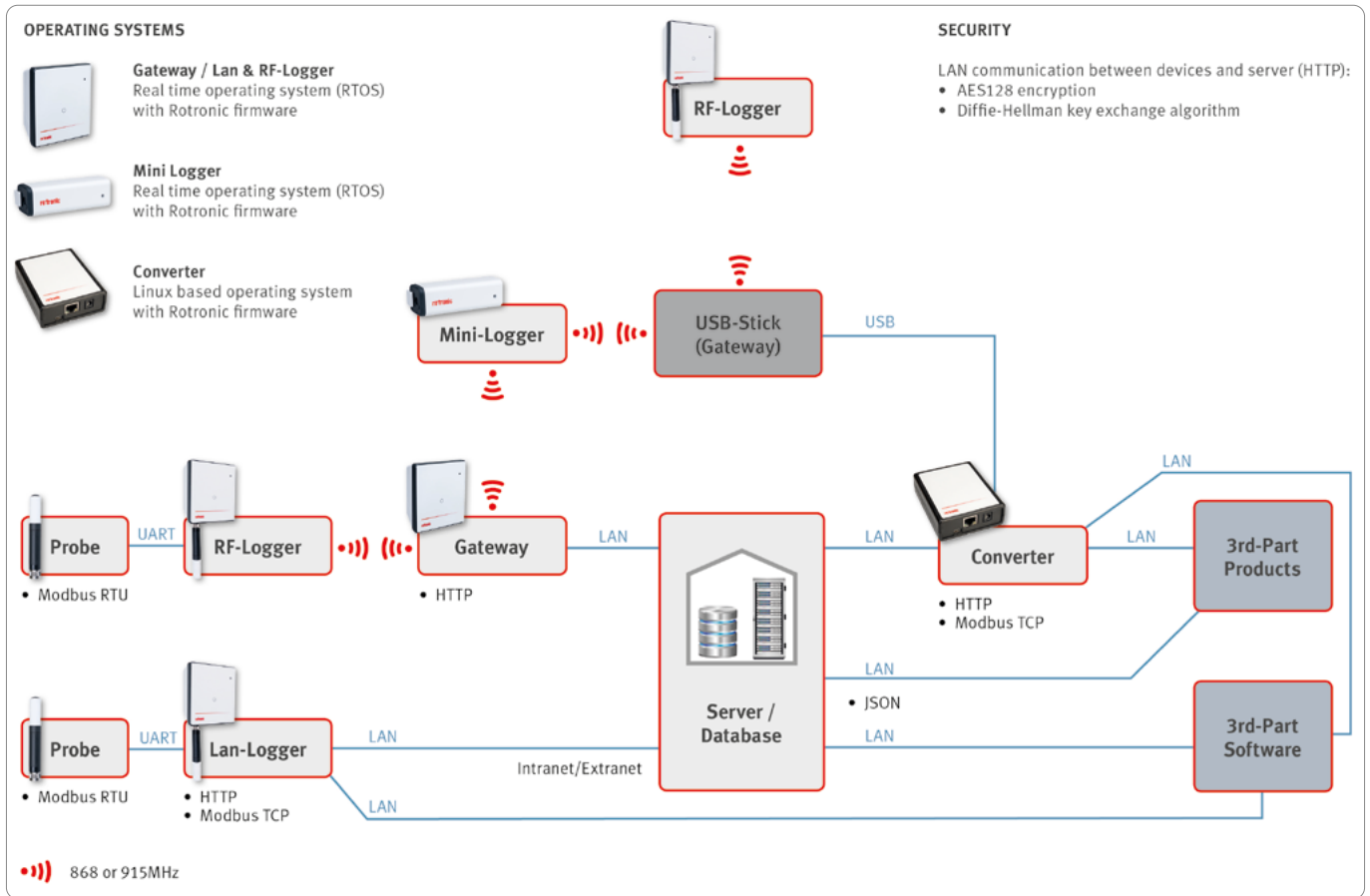

## RMS SERVICES

### Project Procedure

The Rotronic Monitoring System (RMS) is a hardware and software solution adjustable to your requirements for a continuous monitoring system. The complete system conforms to GAMP5, Rotronic is well aware that our support is crucial to your project, so we offer a complete solution. From the user requirement specifications to the IQ/OQ/PQ with our detailed documentation finishing off with tailor made training for your employees.

Furthermore the RMS software is delivered as a GAMP software category 4 system. Our main goal is to fully understand your requirements and deliver the best continuous monitoring system for you and your company.

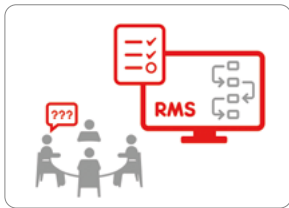

#### Review of the URS

Rotronic has designed a functional description document explaining each and every function of the RMS software. This description will help you create your own URS, but it might also help you adapt the one you already have striving to provide the best risk based approach to compliant GxP computerised systems. Don't know exactly how to build up your URS? No need to worry, Rotronic have the knowledge and documentation required to help support you in any case.

The continuous monitoring system RMS is a very flexible solution both on the hardware and the software side (R&D and production in the Headquarters in Switzerland). You have a problem, let us work together to give you the perfect solution. A personal discussion is of the utmost importance though, only when speaking to you can we really understand your requirements for a continuous monitoring system!

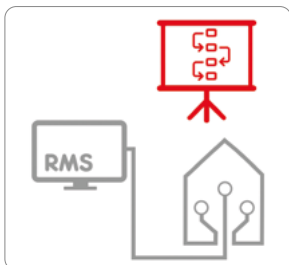

#### Design Concept

After fully understanding your requirements, a project is setup at Rotronic. Each and every step is listed, costs evaluated and an initial time line defined. A crucial point is software adaptations, any adaptations are follow a stringent testing process within Rotronic, so project timing is a key to a successful roll out of your continuous monitoring project.

Rotronic has the possibility to carry out the complete monitoring system project, from the heat mapping of the various areas to the physical installation of the devices. Internally, the project team needs to understand your requirements in order to deliver your solution based upon your time line. Our main aim is an optimised communication based upon information transfer to the entire team: sales, product management, inside sales, after sales, production and R&D are all involved already in this initial process.

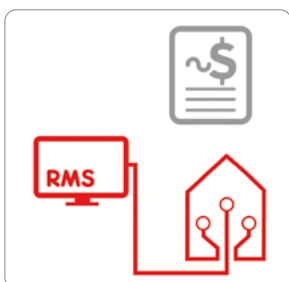

#### Conceptual Offer

Rotronic will give you an initial quotation based upon your URS and the project planning. This initial quotation is rarely the final quotation, but a ball park figure that will help you to get a feeling for the costs of a project. Products will be added and removed, services will be adapted... The initial quotation will help you get a feel for the market and already an understanding of what working with Rotronic is like. We are more than happy to invest time in a project, so that you get the best continuous monitoring solution possible!



**On site Demo Installation**

Pricing and promises in hand, we consider it important that customers actually try out the RMS. Be it via our cloud solution or our server software, our engineering team will offer you a solution based upon your requirements. When you start to play with the software, very quickly, thanks to its simple and effective design, you can work your way through the different functions and get a real understanding for what the system can offer.

With just a few measurement points, you can already get a feeling for what is going on in the various locations that you monitor. Increase of CO<sub>2</sub>, people are in the room, a temperature decrease might mean that the heating has been cut off, the lux increase, the sun is coming up... Everything of course can be verified by adding an IP camera next to the measurement point to confirm what you are seeing.

You can get a feel for the alarming functions, an overview of how the audit trail actually works and what data you can extract from the system! We will support for the optimal installation of your demonstration, you need to test it to understand the flexibility of what Rotronic can offer you. After seeing the demo, new ideas will appear and will help

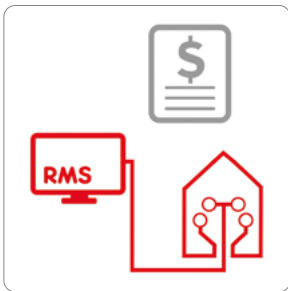

**Final Offer**

You now understand that the sky is not the limit with our universal RMS. You've had new ideas, seen new potential and have accordingly updated your URS. Rotronic has been with you throughout this process and can now give you a tailor made quotation responding to your exact detailed requirements for a continuous monitoring system.



**Verification from the Customer**

Of course, a market comparison is necessary! The flexibility and quality of RMS, the professionalism of our team and the complete package that we can offer will be sure to make Rotronic a very competitive partner for your project. Need more details from our side, don't hesitate to give us a call. Remember, we are FDA 21 CFR Part 11 and GAMP 5 conform for the most demanding applications, but we can also help you with smaller projects where these regulations are not required. With the Rotronic Monitoring System, we have a shoe that fits every foot.



**Installation /Commissioning**

Congratulations on choosing to partner with Rotronic on your project! After a review of the project planning and time lines, we can start with the physical installation of the devices, the setup of the software and SQL database on your server, the configuration of the software and the hardware (this is as well something that you can choose to do on your own, we are always happy to offer a helping hand). The heat mapping or the wireless signal mapping can both be carried out with the helping hand of Rotronic should this be a necessity.



**Validation**

The software is validatable, so time to validate your continuous monitoring system. If you did the URS with the Rotronic documentation, then we can also offer the rest of the validation documentation, the validation master plan, the risk assessment, the functional requirement specifications, the configuration specification, the requirement traceability matrix, the validation script specification, the installation qualification, the operation qualification and the performance qualification of course followed by your tailor made training.

This validation model is based upon the GAMP5 standard and is recognised throughout the pharmaceutical world. The entire validation will prove that your system replies to your URS. Even if you didn't use the Rotronic URS, you can still use the Rotronic documentation as guidelines. With our team of trained professionals, Rotronic can carry out the validation of your system partially or fully if required.



**Maintenance and Support**

Who better to receive support from but from the manufacturer?

Maintaining your system is crucial for the running of your processes. Rotronic offers packages from ISO-17025 and ISO-9001 calibrations only (temperature, relative humidity, dew point, differential pressure) to hardware and software maintenance contracts, build around your requirements. The software is also setup in a way that it makes hardware changes ever so simple and effective. Like the system our support is already very flexible!

## RMS CONTRACT MODULES

Create your tailored version based on the various modules

Software	Hardware	General Support	Installation Services	Onsite Maintenance	Premium Support
<b>PURCHASE</b>	<b>PURCHASE</b>	<b>INCLUSIVE</b>	<b>OPTIONAL</b>	<b>OPTIONAL</b>	<b>COMPULSARY</b>
<b>RENT</b>	<b>PURCHASE</b>	<b>INCLUSIVE</b>	<b>OPTIONAL</b>	<b>OPTIONAL</b>	<b>INCLUSIVE</b>
<b>PURCHASE</b>	<b>RENT</b>	<b>INCLUSIVE</b>	<b>OPTIONAL</b>	<b>OPTIONAL</b>	<b>COMPULSARY</b>
<b>RENT</b>	<b>RENT</b>	<b>INCLUSIVE</b>	<b>OPTIONAL</b>	<b>OPTIONAL</b>	<b>INCLUSIVE</b>

### What we can offer



#### Fast & Easy Software only Solution

Take advantage of our SaaS solution, freeing you from complex software and IT hardware management and benefit from our outstanding IT infrastructure with a state of the art security and data redundancy setup. You are guaranteed to have a 99.01% availability of your data with no hidden costs! You will also benefit from free software improvements and upgrades throughout the lifetime of your monitoring system.

**Contract**  
SaaS Software only



#### Carefree Hardware Solution

You also have the possibility to also rent the hardware from us! Rotronic will keep an inventory of relevant measurement product for you so that you do not have to manage anything other than returning the defective units to us. Should a product fail or break, it will be replaced within 24 working hours<sup>1</sup>. No more issues with making room in your warehouse, finding the devices when you need them and no more cash tied up in possibly never used stock.

**Contract**  
SaaS Software & Hardware



#### Carefree Installation Service

You and your team are too busy or you do not have access to qualified personnel. Your configurable environmental monitoring system can be setup to run, exactly how you want it to as soon as the devices are delivered. Let us install and configure your hardware and software; you will not have to lift a finger!

**Overview**  
Service



#### Carefree Maintenance SLA

Once your system is up and running, who better than Rotronic to service your system. We can calibrate (ISO-17025 or traceable) your devices on a yearly basis, calibrations on site are also possible. At the same time change filters, O-rings and make sure that hardware is running the latest firmware. To guarantee data redundancy, we can also change batteries and ensure that your system is running smoothly.

**SLA**  
Onsite Maintenance

<sup>1</sup> For customers in Switzerland.



**Fully Compliant Exclusive Contract**

For GxP compliant systems that require validation, Rotronic offers a turnkey solution from A to Z. Let us know what your user requirement specifications are and let us provide you with the solution!

**Contract  
Exclusive SaaS**



**On-Premise Support**

If you already have solid IT infrastructure in place, responding to your security policies and up to date with the latest norms, we also offer all of the above with an on-premise software solution.

**Overview  
Support**



**Stay up to date premium Support**

Stay up to date and improve your monitoring with the latest software updates and features sent out to you on a regular basis.

**SLA  
Premium Support**

Questions? Do not hesitate to contact us: [rms@rotronic.ch](mailto:rms@rotronic.ch)

## RMS-HCD

This digital probe is characterized by its high performance. Very low current consumption, the highest degree of accuracy and measurement results within 50 ms are its main features. This is enabled by the new AirChip4000, which together with the HYGROMER® HT-1 sensor forms a powerful combination.

### FEATURES

- Measures relative humidity and temperature
- Outstanding accuracy, repeatability and long-term stability
- Advanced probe housing and construction
- Compatible with RMS data loggers and RMS software
- Low power consumption

General specifications		
Order code	RMS-HCD-S (black) RMS-HCD-S3 (white)	RMS-HCD-IC102 (Industrial probe, 2 m cable)
Humidity sensor	HYGROMER HT-1	
Temperature sensor	PT1000, Class 1/3 B	PT 100, Class 1/3 B
Operating humidity	0...100 %rh	
Operating temperature	-40...+85 °C	-40...+85 °C (Electronics) -100...200 °C <sup>1</sup> (Sensor head)
Accuracy @ 23 °C	±0.8 %rh ±0.1 K	
Long-term stability	1 %rh / year	
Startup time	50 ms	90 ms
Measurement interval	500 ms	
Response time sensor	τ63: <15 s without filter, (temperature and humidity)	
Maximum wind velocity	3.5 m/s without filter	
Supply voltage	2.8...5.5 VDC	3.3...5.5 VDC
Current consumption	0.5 mA	<3 mA
Digital interface	UART	
Protocol	Modbus RTU	
Standards		
Compliance	FDA 21 CFR Part 11 / GAMP5	
Housing / Mechanical parts		
Material	PC, PPS, stainless steel 1.4301	
Protection rating	IP65 (except sensor area)	
Weight	10 g	230 g

<sup>1</sup> Peak load: 100 h. Maximum permissible continuous load: 190 °C



RMS-HCD-S



RMS-HCD-IC102

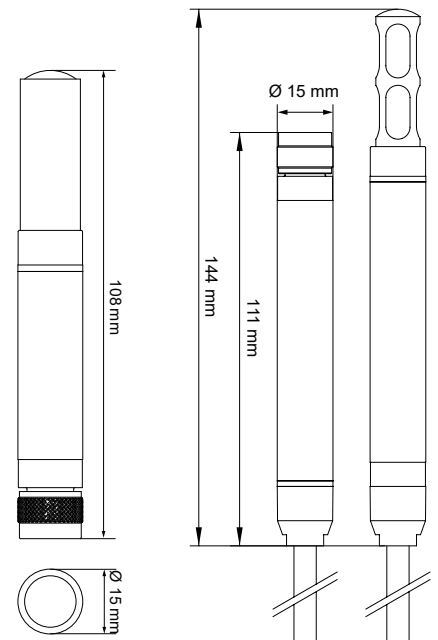

### Compatible

- RMS-LOG-L / RMS-LOG-868 / RMS-LOG-915
- AC3001

### Delivery package

- HygroClip DIGITAL
- Short instruction manual
- Calibration certificate

## RMS-TCD-S-001

The RMS-TCD-S-0001 digital probe was designed for all temperature applications where accuracy and interchangeability are crucial. The temperature probe is attached to a 2m cable to ensure flexibility and ease of use during calibration.

### FEATURES

- Measures temperature
- Outstanding accuracy, repeatability and long-term stability
- Advanced probe housing and construction
- Compatible with RMS data loggers and RMS software
- Low power consumption
- Digital communication
- Hot swap possibility, ensuring little to no downtime
- Automatic serial number replacement documented within the RMS audit trail



General specifications	
Order code	RMS-TCD-S-001
Measurement range	-200...200 °C
Accuracy	±0.25 °C at -50...85 °C
Long term stability	±0.5 °C/year
T63	90 s
Electronics details	
Temperature range	-40...85 °C
Relative humidity range	0...100 %rh
Housing details	
Material	Polycarbonate
Housing potting	Yes
Diameter	Ø15 mm
Length	110 mm
IP Rating	IP65
Connector	Standard Rotronic 7-pin connector
Sensor details	
Temperature sensor	4 wire PT100 Class A (DIN EN 60751)
Material	Stainless steel – austenitic – 1.4571 (316Ti) bar
Sensor potting	Yes
Diameter	Ø3 mm
Length	50 mm
IP Rating	IP68
Battery lifetime	RMS-LOG-868/915/L: @60 s 240 d RMS-LOG-L-D: @60s 18 d
Cable details	
Material	Perfluoroalkoxy alkanes (PFA)
Diameter	Ø2.2 mm
Length	2 m
Temperature range	-190...200°C
Technical details	
Communication	MODBUS RTU
Output signal	UART
Power supply	3.3...5 V
Current consumption	~3.8 mA
Adjustment option 1	2 point user adjustment possible
Adjustment option 2	A, B and C coefficients
Accessories	
Hardware	AC3001, RMS-LOG-L, RMS-LOG-868/915, RMS-LOG-L-D
Software	RMS-CONFIG; Rotronic Monitoring System

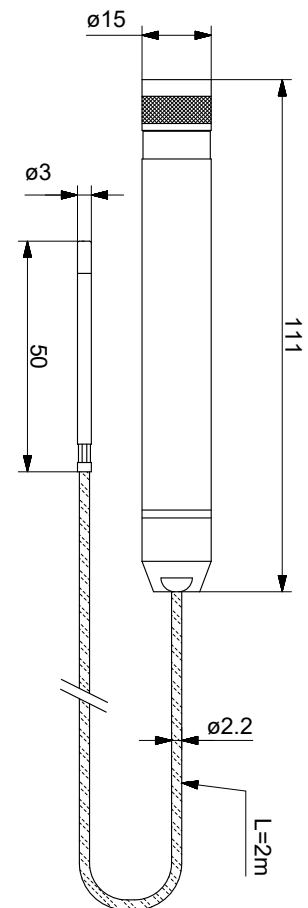

### Compatible

- RMS-TD-0001
- AC3001
- RMS-LOG-L/868/915

### Delivery package

- RMS-TCD-S-001
- Calibration Certificate

## RMS-PCD-S-XXX

The Rotronic differential pressure probes are ideal for clean rooms, operating theaters and applications where even minor differences in pressure can have a big effect. Thanks to our two different measurement methods (thermal mass flow measurement and diaphragm measurement), we offer the perfect solution for every requirement. Together with other measurement parameters, these probes can be integrated in RMS perfectly.

### FEATURES

- High-precision measurement and long-term stability
- With ambient pressure compensation
- Large overload range

General specifications		
Sensor type	Thermal Mass Flow	Membrane
Accuracy <sup>1</sup> at 23 °C ±3 K	±1% FS	±1% FS <sup>2</sup>
Long-term stability <sup>3</sup>	±0.1% FSS/year	±2% FSS/year for ±25Pa probe ±1% FSS/year for ±50Pa probe ±0.5% FSS/year for ±100Pa probe ±0.25% FSS/year for ±250Pa and ±500Pa probes
Zero point compensation <sup>4</sup>	Automatic, 1x per measurement interval	Manual, with external tube; via RMS software <sup>1</sup>
Medium	Air	Air & non-aggressive gases
Ambient pressure compensation	Automatic	Not necessary
Adjustment and calibration	Factory adjustment/calibration: 5 points Customer adjustment: max. 9 points	
Measurement range	-25...+25Pa/-50...+50Pa/-100...+100Pa/-250...+250Pa/-500...+500Pa	
Burst pressure	5 bar	0.7 bar
Leak rate	<180 µl/min.	0 µl/min.
Startup time	<0.5 s	
Measurement interval	1 s probe / ≥10s RMS / 1s Modbus	
Response time τ63	<1 s	
Range of application	-20...+80°C (0...+70°C temp.-comp.) 0...95 %rh non-condensing	
Voltage	3.3 – 5.5 V	
Current consumption	30 mA (avg.)	12 mA (avg.)
Battery life LOG-868/915	350d @ 60s interval	650d @ 60s interval
Battery life LOG-L	395d @ 60s interval	840d @ 60s interval
Protocols	Modbus RTU	

Standards	
Compliance	FDA 21 CFR Part 11 / GAMP5

Housing / Mechanical parts	
Housing material	Polycarbonate (housing) Stainless steel DIN 1.4305 (nuts, connectors)
Fire protection class	Corresponds to UL94-HB
Dimensions	Ø 32 mm x 87 mm
Pressure connections	Tubing connector internal Ø 4 mm x 10 mm
Weight	60 g
IP protection class	IP65

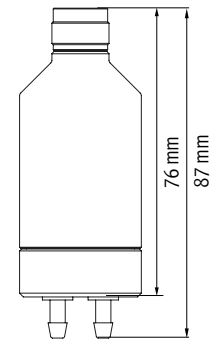
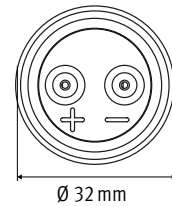

<sup>1</sup> Please see the device manual for detailed considerations.  
<sup>2</sup> For maximum accuracy, Rotronic recommends strongly to perform a zero point compensation after the installation and initial operation and to repeat it annually. For aggressive environments / gas media, a more frequent zero point compensation is advised. Please see the device manual for detailed considerations.  
<sup>3</sup> Highly reducible by a zero point compensation of the RMS-PCD-S-Mxx (membrane sensor).  
<sup>4</sup> A zero point adjustment is recommended for every installation or position change.

### Compatible

- RMS-LOG      Wireless ≥V1.5/LAN data loggers ≥V1.4

### Delivery package

- Differential pressure probe
- Calibration certificate
- Short instruction manual
- Wall-mounted holder
- Short pressure tube internal Ø 4mm x 10cm (PCD-S-Mxx only)

## CCA-S-20X-SET

The CCA-S-20X is an analog probe with NDIR technology for measurement of carbon dioxide (CO<sub>2</sub>). Developed with a pyroelectric infrared detector with dual temperature compensation and an integrated semiconductor temperature sensor to maximize accuracy and minimize drift. The signal is converted to 4...20 mA by the converter with power supply (CCA-S-20X-SET).

### FEATURES

- Measures from 0 to 20 %CO<sub>2</sub>
- Suitable for incubators: 37 °C, 95...98 %rh and 5 %CO<sub>2</sub>
- Interchangeable probes
- ±0.1 °C accuracy in measurement range

General specifications	
Measurement principle	Infrared (NDIR)
Measured parameter	Carbon dioxide concentration (%)
Accuracy	±10 % of measured value
Medium	Air & non-aggressive gases
Long-term stability	±0.24 %CO <sub>2</sub> /year
Temperature dependence	±10 % of measured value
Pressure dependence	±0.15 % of measured value/hPa
Measurement range	0...20 %CO <sub>2</sub>
Application range	-20...50 °C / 0...100 %rh, 700...1200 hPa
Storage conditions	-20...30 °C / 0...95 %rh
Startup time	60 s
Power supply	CCA-S-20X: 3...5 VDC / 80 mA CCA-S-20X-Set: 24 VDC / 150 mA
AC adapter requirements	100...240 VAC / 50...60 Hz / 0.3 A
Output signal	4...20 mA (CCA-S-20X-SET) 0.4...2.0 V (CCA-S-20X only sensor)
Conformity with Standards	
FDA / GAMP directives	FDA CFR21 Part 11 / GAMP 5
Housing / Mechanical parts	
Enclosure material	Polycarbonate (housing) Stainless steel DIN 1.4305 (nut)
Fire protection class	Corresponds to UL94-HB
Dimensions	Sensor: 32 mm x 87 mm Converter box: 100 mm x 77 mm x 40 mm (LxWxH)
IP protection class	IP40
Weight	55 g sensor 200 g converter box

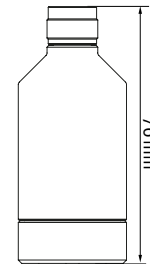
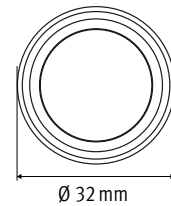

Fig.: CCA-S-20X-SET

### Compatible

- Analog Input                      RMS-MADC-868/915-A
- CO<sub>2</sub> Sensor                        RMS-ADC-L-R
- RMS On-Premise                 CCA-S-20X
- RMS SaaS solutions             RMS-WEB
- RMS-CLD

### Delivery package

- CCA-S-20X
- Power supply
- Converter box
- E2-01XX

## RMS Wall Data Logger

The data logger is the flexible component between the probe and the database in the Rotronic Monitoring System. It stores 44,000 pairs of measured values and transmits them to the RMS database via LAN or wireless link. It guarantees absolute data protection, even if power supply and communications should break down temporarily.

### FEATURES

- 44,000 data point memory
- Fail-safe, thanks to internal battery
- Wireless or LAN interface

General specifications			
Measured parameters	Humidity & temperature, CO <sub>2</sub> , differential pressure, LDP		
Range of application	-40..70 °C / 0..100 %rh		
Storage conditions	-40..30 °C / 0..95 %rh		
Maximum altitude	2000 m ASL		
Power supply	24 VDC ±10 % / <100 mA / Battery: RMS-BAT (2xAA, LiSocI2) / PoE: 802.3af-2003, Class 1		
AC adapter requirements	24 VDC ±10 % / 4 W nominal / <15 W power-limited		
Battery life	3 years (at 23 °C, measurement interval 1 min., HCD-S probe)		
Device data			
Measurement interval	10 s to 15 min.		
Startup time	< 10 s		
Order code	RMS-LOG-L	RMS-LOG-868	RMS-LOG-915
Interfaces	Ethernet	ISM 868 MHz	ISM 915 MHz
Indoor wireless range	-	20..50 meters	15..25 meters
Protocols	HTTP / MODBUS TCP		
Ethernet cable requirement	Min. Cat. 5, SFTP, max. 30 m		
Conformity with standards			
FDA / GAMP directives	FDA CFR21 Part 11 / GAMP 5		
Housing / Mechanics			
Housing material	ABS		
Fire protection class	UL94 -V2		
Dimensions	105 x 113 x 38 mm		
IP protection class	IP65		
Weight	200 g		

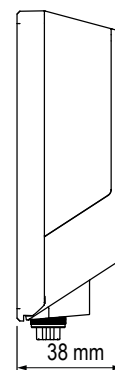
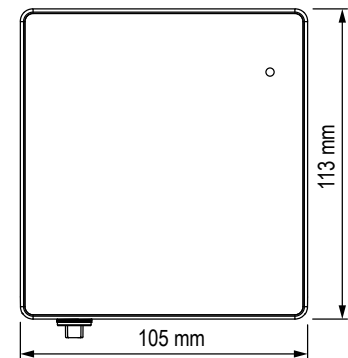

### Compatible

- |                            |                |
|----------------------------|----------------|
| • HygroClip DIGITAL        | HCD/PCD/CCD    |
| • RMS Gateway              | RMS-GW-868/915 |
| • RMS On-premises software | RMS-WEB        |
| • RMS SaaS solutions       | RMS-CLD        |

### Delivery package

- Data logger
- 2 batteries
- Wall bracket
- Short instruction manual
- 2 screws & 2 plugs

## RMS Data Logger with Display

The RMS-LOG-L-D stores up to 44,000 pairs of measured values and transmits them to the RMS database via LAN link. Thanks to its autonomous operation, the logger can display current readings as well as visual and audible alarms even if the power supply and communication should fail temporarily.

### FEATURES

- 44,000 data point memory
- Visual and audible alarms
- Autonomous operation on failure
- Redundant power supply

General specifications	
Measurement interval	10 s to 300 s
Startup time	< 10 s
Software compatibility	≥ V1.3.0, from V2.1 all functions
Application range	-20...70 °C, non-condensing
Storage conditions	-20...30 °C, non-condensing
Maximum altitude	2000 m ASL
Power supply	24 VDC ±10% / Battery: RMS-BAT (2xAA, LiSocI2)
Current consumption max.	50 mA
AC adapter requirements	24 VDC ±10%, 4 W minimum, > 5 W Limited Power Source
PoE	802.3af-2003, Class 1
Device data	
Order code	RMS-LOG-L-D
Ethernet cable requirement	Min. Cat 5, SFTP, max. 30 m
Interface	Ethernet
Protocols	HTTP / Modbus TCP
Number of measuring points	2
Battery life (@60 s and 600 s interval)	HCD-S / HCD-IC: 7 d CCD-S-XXX: 2.4 d PCD-S-XXX: 15 d
HCD-S / HCD-IC	7 d
CCD-S-XXX	2.4 d
PCD-S-XXX	15 d
Storage capacity	44,000 data points
Conformity with standards	
Soldering material	Lead free / RoHS conformity
FDA/GAMP directives	FDA CFR21 Part 11 / GAMP 5
Housing / Mechanics	
Enclosure material	PC, ABS
Dimensions	105 x 113 x 38 mm
IP protection class	IP65
Fire protection class	UL94-V2
Weight	240 g

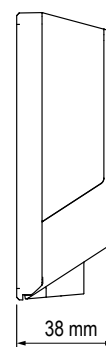
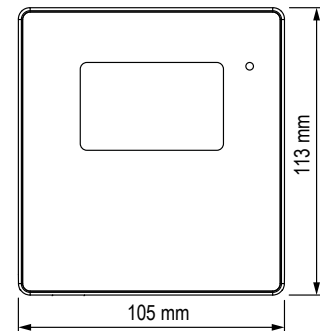

### Compatible

- HygroClip DIGITAL HCD/PCD/CCD
- RMS On-premises software RMS-WEB
- RMS SaaS solutions RMS-CLD
- Autonomous operation and audible alarms from V2.1

### Delivery package

- Data logger, with clamps
- Short instruction manual
- 2 batteries
- Certificate
- Velcro strips

## RMS-LOG-T30-L/868/915

The RMS-LOG-T30 is a data logger with two integrated analog-to-digital converters, to which two PT100 sensors can be connected for high-precision temperature measurement. The measuring accuracy of the data logger with PT100 can be improved by a 1- or 2-point adjustment. The data logger stores 44,000 pairs of measured values and sends them to the RMS database via LAN or wireless interface.

### FEATURES

- Saving of up to 44,000 data points
- 2 x PT100 sensor connections
- 2-, 3- or 4-wire connection
- ±0.1 °C accuracy in measurement range

General specifications			
Measured parameters	2-, 3- and 4-wire RTD measurement		
Number of measuring points	2 x PT100 probes		
Accuracy <sup>1</sup> (@23 °C, without PT100)	±0.1 °C (-100 °C to 200 °C)		
	±0.2 °C (-200 °C to 850 °C)		
Application range	-40...70 °C 0...100 %rh		
Storage conditions	-20...30 °C 0...95 %rh		
Power	24 VDC ±10 % / <100 mA / PoE: 802.3 af-2003, Class 1		
AC adapter requirements	24 VDC ±10 % / >4 W / power-limited		
Device data			
Measurement interval	10 s to 15 min.		
Order code RMS-LOG-T30-xxx	T30-L	T30-868	T30-915
Battery life (23 °C, 60 s interval)	3 years	2.4 years	2.4 years
Interfaces	Ethernet	ISM 868 MHz	ISM 915 MHz
Indoor wireless range	-	20...50 meters	15...25 meters
Compatibility with RMS-GW-xxx Firmware	-	V2.1	V2.1
Compatibility with Software	≥ V1.3.0		
Protocols	HTTP / MODBUS TCP (T30-L)		
Ethernet cable requirement	Min. Cat 5, SFTP, max. 30 m		
Conformity with standards			
FDA / GAMP directives	FDA CFR21 Part 11 / GAMP 5		
Housing / Mechanics			
Housing material	PC, ABS		
Fire protection class	UL94-V2		
Dimensions	105 x 113 x 38 mm		
IP protection class	IP65		
Weight	240 g		

<sup>1</sup> In order to improve the measurement accuracy when using the data logger and the PT100, it is possible to carry out a 1-point or 2-point adjustment. To calculate the total accuracy of the RMS-LOG-T30, all variables must be added.

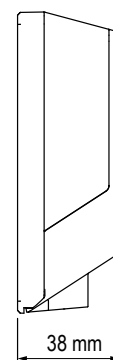
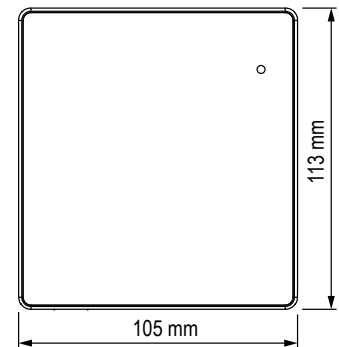

### Compatible

- |                            |          |
|----------------------------|----------|
| • RMS Gateway              | RMS-GW   |
| • RMS On-premises software | RMS-WEB  |
| • RMS SaaS solutions       | RMS-CLD  |
| • PT100 probe              | T30-000X |

### Delivery package

- Data logger
- 2 batteries
- Wall bracket
- Short instruction manual
- 2 cable glands M12 x 1.5

## RMS Mini Logger

The wireless mini data logger is the low-cost data logger in the Rotronic Monitoring System. Its small housing and wireless interface make it a really flexible data logger. The mini logger is available in various sensor variants: internal temperature sensor (NTC), external temperature sensor (NTC), light, voltage measurement, current measurement or digital switch contact. With this versatility, it can monitor refrigerators and incubators, as well as door contacts and OEM analog devices.

### FEATURES

- Stores 10,000 measured values
- Fail-safe, thanks to internal battery
- Battery life up to 2.5 years
- Depending on the version, it measures temperature, current, voltage or light, or monitors a digital switch input
- ISM band 868 MHz / 915 MHz

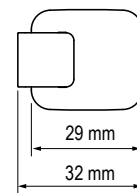
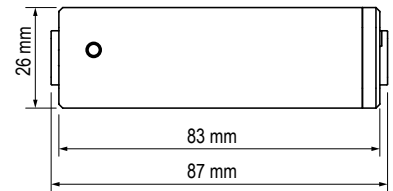

General specifications		
Device type	MS-MLOG-XXX-XXX RMS-MDI-XXX RMS-MADC-XXX-X	RMS-MLOG-BT-XXX RMS-MLOG-B-XXX
Memory size	10,000 measured values	13,000 data points
Range of application (electronics)	-30...85 °C / 0...100 %rh	-40...85 °C / 0...100 %rh
Battery life @23°C, 1 minute interval	2.2 years	2.5 years
IP protection class	IP65	IP30 (B), IP65 (BT)
Working range pressure	300...1100 hPa	
Storage conditions	-30...30 °C / 0...95 %rh	
Battery	1x RMS-BAT	
Measurement interval	10 s to 15 min (software dependant)	
Wireless specifications		
Wireless interface	ISM 868 MHz	ISM 915 MHz
Indoor wireless range	20...50 meters	15...25 meters
Conformity with standards		
FDA / GAMP directives	FDA 21 CFR Part 11 / GAMP5	
Housing / Mechanics		
Housing material	ABS	
Dimensions	83 x 29 x 29 mm	
Fire protection class	UL94-V2	

### Measured parameters

RMS-MLOG-B-XXX	Temperature & humidity
RMS-MLOG-BT-XXX	Temperature & barometric pressure
RMS-MLOG-T-XXX	Temperature
RMS-MLOG-T10-XXX	Temperature with external probe (NTC)
RMS-MADC-XXX-V (0...10 V)	Power
RMS-MADC-XXX-A (0...20 mA)	Power input
RMS-MDI-XXX	Digital input
RMS-MLOG-LGT-XXX	Illumination

### Compatible

- Temperature probe T10-xxxxx
- RMS Gateway RMS-GW-868
- RMS On-premise RMS-WEB
- RMS SaaS solutions RMS-CLD

### Delivery package

- Data logger
- Battery
- Wall bracket
- Short instruction manual
- 2 screws & 2 plugs

## RMS Gateway

The gateway is the interface between the wireless data logger and the server software. It can manage up to 60 data loggers simultaneously, collecting all wireless-logger measurement data, and passing them on to the server software. When several gateways are used in the same network, they are configured redundantly. If one gateway should fail, the measurement values are automatically sent to the server software via another gateway.

### FEATURES

- Connects 60 wireless data loggers simultaneously
- 5 wireless channels for parallel and redundant operation

General specifications		
Range of application	-40..70 °C, 0..100 %rh	
Storage conditions	-40..30 °C, 0..95 %rh	
Maximum altitude	2000 m ASL	
Power supply	24 VDC ±10 % / <100 mA / PoE: 802.3 af-2003, Class 1	
AC adapter requirements	24 VDC ±10 % / 4 W nominal / <15 W power-limited	
Device data		
Measurement interval	10 s to 15 min.	
Startup time	< 10 s	
Order code	RMS-GW-868	RMS-GW-915
Interfaces	Ethernet & ISM868 MHz	Ethernet & ISM 915 MHz
Indoor wireless range	20..50 meters	15..25 meters
Protocols	HTTP	
Ethernet cable requirement	Min. Cat. 5, SFTP, max. 30 m	
Conformity with standards		
FDA / GAMP directives	FDA CFR21 Part 11 / GAMP 5	
Housing / Mechanics		
Housing material	ABS	
Fire protection class	UL94 -V2	
Dimensions	105 x 113 x 38 mm	
IP protection class	IP65	
Weight	200 g	

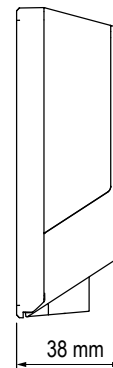
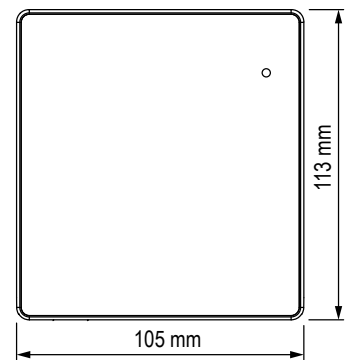

### Compatible

- |                            |          |
|----------------------------|----------|
| • RMS Data Logger          | RMS-LOG  |
| • RMS Mini Logger          | RMS-MLOG |
| • RMS Display              | RMS-D    |
| • RMS On-premises software | RMS-WEB  |
| • RMS SaaS solutions       | RMS-CLD  |

### Delivery package

- Gateway
- Wall bracket
- Short instruction manual
- 2 screws & 2 plugs

## RMS Display

The LAN display is a freely configurable display. As a remote display, it can be placed optimally where it suits the viewer best. It is able to show the measured values, states and alarms of RMS products. The display shows up to four measured values. Two measured values are shown at a time. If more than 2 measured values have been selected, the display alternates between the values that are to be displayed every 5 seconds.

### FEATURES

- Shows up to 4 measured values
- Automatic adjustment of backlight on alarm

General specifications	
Device type	RMS Display
Display of measuring points	Up to 4 measuring points
Range of application	-20...70 °C / 0...100 %rh
Storage conditions	-20...30 °C / 0...95 %rh
Power supply	24 VDC ±10 % / <100 mA / PoE: 802.3 af-2003, Class 1
AC adapter requirements	24 VDC ±10 % / >4 W / power-limited
Measurement interval	10 s
Interface	Ethernet
Protocols	HTTP
Conformity with standards	
FDA / GAMP directives	FDA CFR21 Part 11 / GAMP5
Housing / Mechanical parts	
Housing material	PC, ABS
Fire protection class	UL94-V2
Dimensions	105 x 113 x 38 mm
Display diagonal	2.26 inch
IP protection class	IP65
Weight	206 g

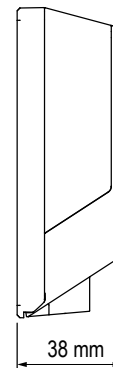
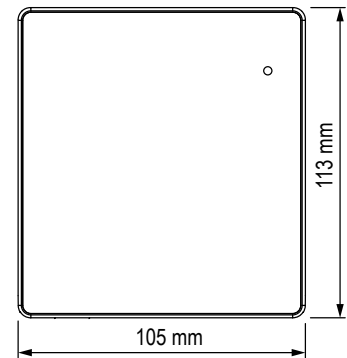

### Compatible

- All measuring points
- RMS Gateway RMS-GW-868
- RMS On-premise RMS-WEB
- RMS SaaS solutions RMS-CLD

### Delivery package

- Display
- Wall bracket
- Short instruction manual
- 2 screws & 2 plugs

## RMS-ADC-L-R

The RMS-ADC-L-R is a data logger with two integrated analog-to-digital converters to which two sensors can be connected for high-precision analog measurement. The data logger stores 44,000 pairs of measured values and sends them to the RMS database via LAN.

### FEATURES

- 44,000 data point memory
- 2 analog sensor inputs
- Various scaling: 0...1/5/10 V and 0/4...20 mA
- ±0.03 % f.s. measurement range accuracy

General specifications	
Measurement interval	10 s to 15 min
Startup time	< 10 s
Software compatibility	≥ V1.3.0
Protocols	HTTP / MODBUS TCP
Ethernet cable requirement	Min. Cat 5, SFTP, max. 30 m
Application range	-40...70 °C, non-condensing
Storage conditions	-20...30 °C, non-condensing
Sensor power supply (Vex)	24 V / 80 mA max.
Current consumption	< 160 mA
AC adapter requirements	24 VDC ±10 %, 4 W minimum, > 5 W power-limited
PoE	802.3af-2003, Class 1
Conformity with standards	
Soldering material	Lead free / RoHS conformity
FDA/GAMP directives	FDA CFR21 Part 11 / GAMP 5
Device data	
Accuracy	± 0.03 % full-scale
Temperature accuracy	± 0.02 % full-scale / °C
Measuring resistance / Load	25 kΩ at voltage input 250 Ω at current input
Number of measuring points	1 or 2 analog inputs
Measurement ranges	0...1 V, 0...5 V, 0...10 V, 0...20 mA and 4...20 mA
Storage capacity	44,000 data points
Sensor quality	<ul style="list-style-type: none"> <li>• Detection of sensor interruption (open loop)</li> <li>• Detection of overload</li> <li>• Detection of underload at 4...20 mA</li> </ul>
Housing / Mechanics	
Housing material	PC. ABS
Dimensions	110 x 119 x 22.5 mm
IP protection class	IP20
Fire protection class	UL94-V0
Weight	125 g

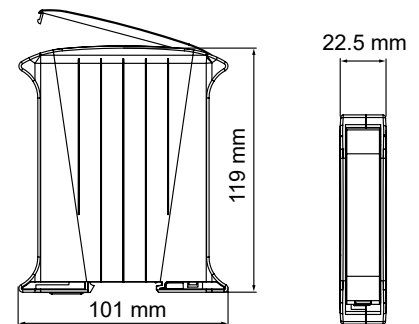

### Compatible

- RMS On-premises software ≥ V1.3.0
- RMS SaaS solutions ≥ V1.3.0

RMS-WEB  
RMS-CLD

### Delivery package

- Data logger, with clamps
- Short instruction manual
- Certificate

## RMS-DI-L-R

The digital input module stores all measured data on an event basis and sends it to the database via Ethernet. The minimum pulse time is 100 ms. Should the connection be lost, the module stores the data intermediately to protect data integrity and fills up the data gaps when the connection has been restored. The device has a battery so that logging of measured data is also ensured in the event of a failure in the external power supply.

### FEATURES

- Two input channels
- Data logging of up to 75,000 measured values



General specifications	
Device type	RMS-DI-L-R
Number of inputs	2 independent digital inputs
Range of application	-40..70 °C / 0..100 %rh non-condensing
Storage conditions	-40..30 °C / 0..95 %rh
Maximum altitude	2000 m ASL
Power supply	24 VDC ±10 % / <100 mA / PoE: 802.3 af-2003, Class 1
AC adapter requirements	24 VDC ±10 % / 4 W nominal / <15 W power-limited
Battery type	RMS-BAT
Battery life	3 years at 23 °C
Device data	
Input frequency	Max. 0.833 Hz or 1.2 s
Pulse recognition	>100 ms (periodically > 1.2 s)
Input circuit	Logic level: 0 V / 5-24 V
	Trigger threshold: ~3.77 V
	Current consumption: <1 mA
Reed circuit	Max. load at input 100 kΩ
Max. cable length at input	<3 m
Measurement interval	Event-based & interval (10 s to 15 min.)
Storage capacity	75,000 data points
Interface	Ethernet
Protocols	HTTP
Conformity with standards	
FDA / GAMP directives	FDA CFR21 Part 11 / GAMP 5
Housing / Mechanical parts	
Housing material	Polycarbonate (PC)
Fire protection class	UL94-V0
Dimensions	89.7 x 62.2 x 108 mm
IP protection class	IP20
Weight	206 g

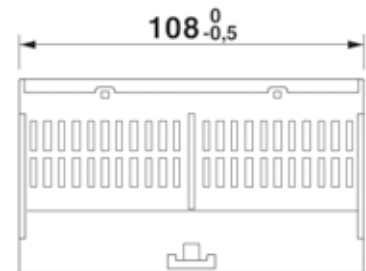
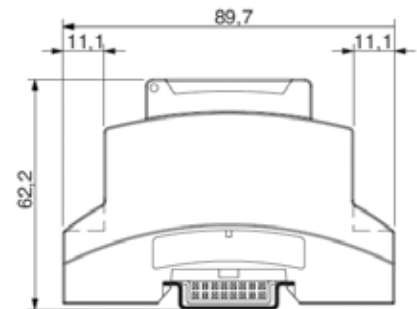

### Compatible

- RMS-Config
- RMS On-premise RMS-WEB
- RMS SaaS solutions RMS-CLD

### Delivery package

- Digital module
- 2 batteries
- Wall bracket (wall-mounted housing)
- Short instruction manual
- 2 screws & 2 plugs

## RMS-DO-L-R

The digital output module serves to display information, issue alarms and control events. The relays can be interrogated or set via Modbus TCP or the RMS software. It is possible to define the conditions in the RMS software and to actuate the outputs on the basis of them.

### FEATURES

- Two output channels

General specifications	
Device type	RMS-DO-L-R
Number of outputs	2, polarity-independent
Range of application	-40..70 °C / 0..100 %rh non-condensing
Storage conditions	-40..30 °C / 0..95 %rh
Maximum altitude	2000 m ASL
Power supply	24 VDC ±10 % / <100 mA / PoE: 802.3 af-2003, Class 1
AC adapter requirements	24 VDC ±10 % / 4 W nominal / <15 W power-limited
Device data	
Interface	Digital signal / galvanically isolated
Relay switching capacity	50 VAC (peak) 1 A / 50 VDC/1 A, polarity-independent
Voltage output (VEX)	24 VDC (Note: The maximum current available depends on the external power supply connected)
Max. cable length at input	<3 m
Measurement interval	>=10 s
Interface	Ethernet
Protocols	HTTP
Conformity with standards	
FDA / GAMP directives	FDA CFR21 Part 11 / GAMP 5
Housing / Mechanical parts	
Housing material	Polycarbonate (PC)
Fire protection class	UL94-V0
Dimensions	89.7 x 62.2 x 108 mm
IP protection class	IP20
Weight	155 g

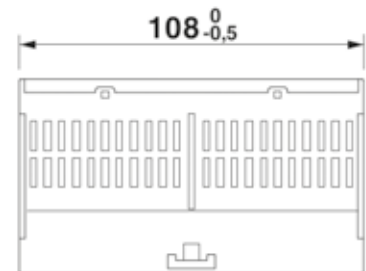
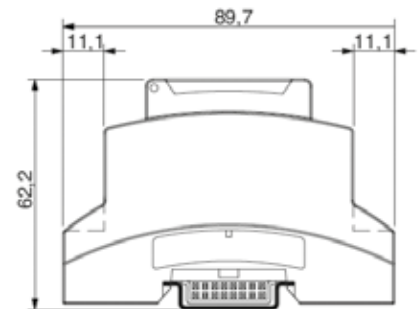

### Compatible

- RMS-Config
- RMS On-premise RMS-WEB
- RMS SaaS solutions RMS-CLD

### Delivery package

- Digital module
- Wall bracket (wall-mounted housing)
- Short instruction manual
- 2 screws & 2 plugs

## RMS Converter

The RMS Converter allows you to easily integrate existing devices and networks into RMS. The RMS Converter acts as an interface, gathering the data from digital devices and sending them to the RMS server software/MS SQL database. In addition, third party digital devices can be integrated if the communication protocol is MODBUS TCP. However, this function requires support from the Rotronic R&D. Where ever possible Rotronic would recommend replacing previous networks with RMS devices in the long term.

### FEATURES

- Integrates digital devices seamlessly into RMS
- Integrates Rotronic digital devices into RMS
- No loss of accuracy due to A/D converters, show up to 5 decimal values

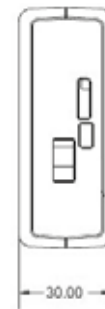
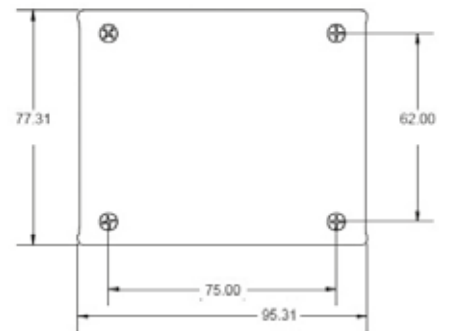

General specifications	
Device type	RMS Converter
Number of measuring points	Integration of up to 100
Range of application	-0 .. 50 °C / 0 .. 95 %rh
Storage conditions	-0 .. 50 °C / 0 .. 95 %rh
Electrical Supply	5 VDC (universal mains adapter included)
Measurement interval	10 s to 15 min
Interface	Ethernet
Protocols	Modbus TCP RoASCII HTTP SNMP Customer-specific enhancements
Supported webcams	D-Link DCS-2121
Conformity with Standards	
FDA / GAMP directives	FDA 21 CFR Part 11 / GAMP5
Housing / Mechanical parts	
Dimensions	94 x 78 x 30 mm
IP protection class	IP20

### Compatible

- |                                 |                               |
|---------------------------------|-------------------------------|
| • Transmitter                   | HF4..HF8 (Ethernet)           |
| • Transmitter                   | PF4/5 (Ethernet)              |
| • RMS On-Premise                | RMS-WEB                       |
| • RMS SaaS solutions            | RMS-CLD                       |
| • Clean room panel              | CRP5                          |
| • Analogue to digital converter | RMS-8ADC-L-R-A/V              |
| • RTD to digital converter      | RMS-4RTD-L-R                  |
| • Particle counter              | All with Modbus TCP interface |

### Delivery package

- Converter
- Short instruction manual
- AC adapter
- Ethernet cable
- USB cable

## AD-0001

The AD-0001 will warn users both visually and aurally of any alarms that are setup within the Rotronic monitoring system. Alarms can be setup via the alarm scheme as well as via the script function (IF/OR/AMD/THEN) and then triggered from the actions settings.

### FEATURES

- Direct visual or sound alarming
- Alarming via thresholds or scripts (IF/OR/AND/THEN)
- Permanent or blinking red LED
- Permanent or pulsing buzzer

General specifications	
Device type	AD-0001
Range of application	-20...50 °C / 0...95 %rh
Storage conditions	-0...50 °C / 0...95 %rh
Electrical supply	24 VDC (power can be supplied via the RMS-DO-L-R)
Light	Red LED
Sound	< 85 dB
Housing / Mechanical parts	
Height	154.5 mm without mounting bracket
Diameter	70 mm
IP protection class	IP65
Housing material	PA and PC

### Sound pressure level dB (A)

		Distance in m										
1	2	3	5	10	20	30	50	100	200	300	500	1000
100	94	90	86	80	74	70	66	60	54	50	46	40
90	84	80	76	70	64	60	56	50	44	40		
85	79	75	71	65	59	55	51	45	39			
70	64	60	56	50	44	40	36					

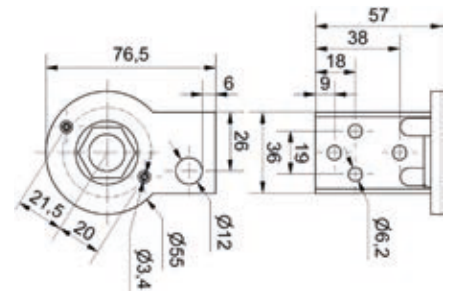

#### Compatible

- RMS-DO-L-R

#### Delivery package

- Device

## RMS-TD-0001

Strict guidelines require high temperature stability in many areas and only allow the smallest fluctuations. However, there are unavoidable fluctuations fridge temperature when the door opens, which must be buffered to ensure that the probe temperature measurement is representative of the product temperature. As of such, the monitored temperature is more stable and meaningful. The sensor holder is traceable end-to-end and meets all FDA and GxP environments.

### FEATURES

- Ensure that the temperature measurement is representative of the product temperature with this temperature buffer
- Easy installation of temperature probes in fridges and freezers

General specifications	
Order code	RMS-TD-0001
Temperature range	-196...40 °C
PET bottle	Polyethylene terephthalate (PET)
Mounting bracket	Poly lactide (PLA)
Sand	Biloxit (certified)
Dimensions	34 x 110 mm



### Delivery package

- PET bottle
- Lid with seal
- Sand (weighed for the bottle)
- Two centering sleeves (suitable for 6 mm diameter probes only)
- Mounting bracket
- Cable ties

## WB-0001

The WB-0001 detects the presence of water or conductive fluids once it reaches a level that bridges the two conductive strips on the bottom of the housing. Once the strips are bridged, audible and visual alerts as well as an internal switch are triggered. The sensing height can be adjusted from 0.08 mm to 13.5 mm using the included adjustable mounting bracket (that can be attached to any flat surface by either using the attached adhesive strips or mounting screws).

### FEATURES

- Detect leaks as soon as they occur
- Visual and audible alarm
- Battery powered
- Adjustable sensing height
- Relay output

General specifications	
Parameters	Water or conductive fluids
Range of application	0...50 °C
Power supply	3V CR2450 lithium metal battery
Battery lifetime	5 years steady state / 48 hours during alarm condition
Power consumption	0.9 mA steady state / 3.0 mA during alarm condition
Dimensions	53 x 105.23 x 30.77 mm
Housing	ABS and polycarbonate
Cable length	1.5 m
IP protection class	Water tight up to 3/4 of the body height
Weight	137.5 g
Technical Information / Functions	
Switch type	SPST NO SSR
Audible alarm	At least 85dB @30 cm distance
Visual alarm	Red LED for water level, Yellow LED for low battery

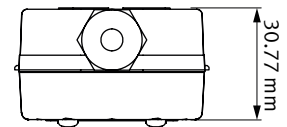
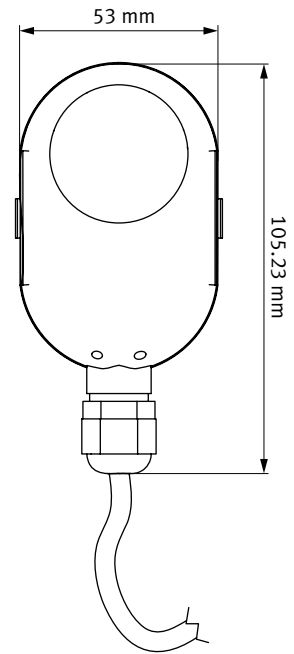

### Compatible

- RMS-MDI-868/915
- RMS-DI-L-R

### Delivery package

- 1 CR2450 lithium metal battery
- Short instruction manual

## Temperature probes

The RMS temperature portfolio will cover a various array of applications, from the coldest such as liquid nitrogen tanks and cryogenic freezers to freezers, refrigerators and cold rooms to hotter ones such as water baths, incubators, ovens and autoclaves. Certain probes are also designed for specific applications for monitoring legionella within water pipes and monitoring room temperature.

### T10-0001

---

- Applications: liquid nitrogen, cryogenics...
- Application range: -196...-90 °C
- Cable length: 2 m
- Probe diameter: 6-6.15 mm
- Probe length: 50 mm
- IP65
- Select NTC T10-0001 within RMS
- Sensor: NTC



### T10-0002

---

- Applications: Dry ice, freezers...
- Application range: -80...150 °C
- Cable length: 2 m
- Probe diameter: 6-6.15 mm
- Probe length: 50 mm
- IP65
- Select NTC T10-0002/0006 within RMS
- Sensor: NTC

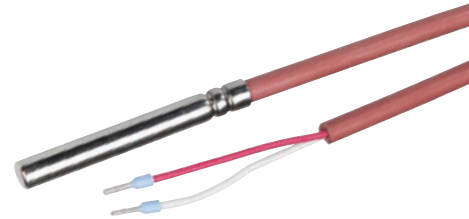

### T10-0003/T10-0013/T10-0113

---

- Applications: freezers, fridges, cold rooms, water baths, incubators, ovens...
- Application range: -50...120 °C
- Cable length: 2 m
- Probe diameter: 6-6.15 mm
- Probe length: 50 mm
- IP65
- Select NTC T10-0003/4 within RMS
- Sensor: NTC

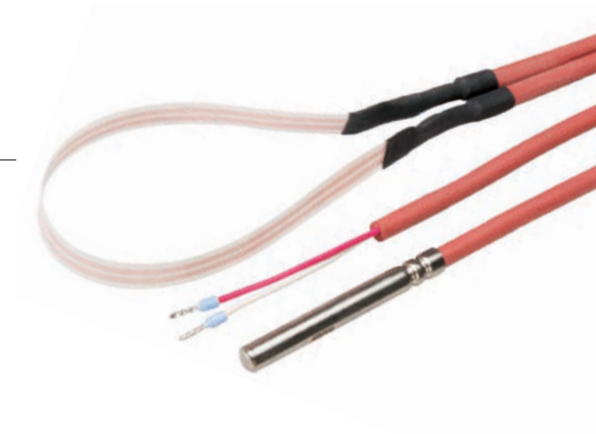

## Temperature probes

### T10-0005

- Applications: Dry ice, freezers...
- Application range: -90...0 °C
- Cable length: 4 m
- Probe diameter: 6-6.15 mm
- Probe length: 50 mm
- IP68
- Select NTC T10-0005 within RMS
- Sensor: NTC

### T10-0006

- Applications: freezers, fridges, cold rooms, water baths, incubators, ovens...
- Application range: -80...150 °C
- Cable length: 4 m
- Probe diameter: 6-6.15 mm
- Probe length: 50 mm
- IP65
- Select NTC T10-0002/0006 within RMS
- Sensor: NTC

### T30-0001

- Applications: Cryotechnology, dry ice
- Application range: -196...260 °C
- Cable length: 2000 mm
- Probe diameter: 6-6.15 mm
- Probe length: 50 mm
- IP68
- Sensor: 4 wire Pt100

### T30-0003

- Applications: Standard
- Application range: -50...200 °C
- Cable length: 2000 mm
- Probe diameter: 6 mm
- Probe length: 50 mm
- IP65
- Sensor: 4 wire Pt100

### T30-0006

- Applications: Standard
- Application range: -50...200 °C
- Cable length: 4000 mm
- Probe diameter: 6 mm
- Probe length: 50 mm
- IP65
- Sensor: 4 wire Pt100

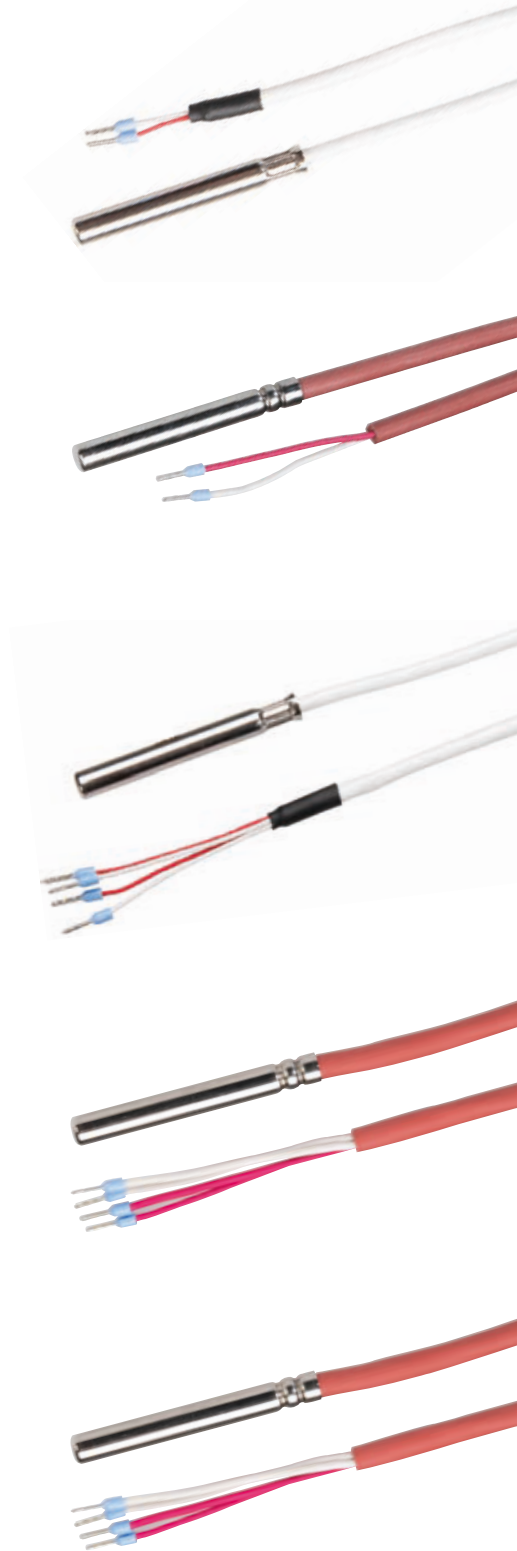

## Temperature probes

### T30-0010

---

- Application range: -190...200 °C
- Cable length: 4000 mm
- Probe diameter: 3.6 mm
- Probe length: 50 mm
- IP65
- Sensor: 4 wire Pt100

### T30-0012

---

- Application range: -190...260 °C
- Cable length: 2000 mm
- Probe diameter: 3 mm
- Probe length: 50 mm
- IP68
- Sensor: 4 wire Pt100

### T30-0013

---

- Applications: Doors
- Application range: -50...200 °C
- Cable length: 2000 mm
- Probe diameter: 6 mm
- Probe length: 50 mm
- IP65
- Sensor: 4 wire Pt100

