

This authorizes the application of the Certification Mark(s) shown below to the models described in the Product(s) Covered section when made in accordance with the conditions set forth in the Certification Agreement and Listing Report. This authorization also applies to multiple listee model(s) identified on the correlation page of the Listing Report.

This document is the property of Intertek Testing Services and is not transferable. The certification mark(s) may be applied only at the location of the Party Authorized To Apply Mark.

Applicant: BEKA associates Ltd
Old Charlton Road
Address: Hitchin
Herts SG5 2DA
Country: United Kingdom

Manufacturer: BEKA associates Ltd
Old Charlton Road
Address: Hitchin
Herts SG5 2DA
Country: United Kingdom

Party Authorized To Apply Mark: Same as Manufacturer
Report Issuing Office: Intertek Testing & Certification Ltd., Leatherhead

Control Number: 4008610

Authorized by:



for L. Matthew Snyder, Certification Manager



This document supersedes all previous Authorizations to Mark for the noted Report Number.

This Authorization to Mark is for the exclusive use of Intertek's Client and is provided pursuant to the Certification agreement between Intertek and its Client. Intertek's responsibility and liability are limited to the terms and conditions of the agreement. Intertek assumes no liability to any party, other than to the Client in accordance with the agreement, for any loss, expense or damage occasioned by the use of this Authorization to Mark. Only the Client is authorized to permit copying or distribution of this Authorization to Mark and then only in its entirety. Use of Intertek's Certification mark is restricted to the conditions laid out in the agreement and in this Authorization to Mark. Any further use of the Intertek name for the sale or advertisement of the tested material, product or service must first be approved in writing by Intertek. Initial Factory Assessments and Follow up Services are for the purpose of assuring appropriate usage of the Certification mark in accordance with the agreement, they are not for the purposes of production quality control and do not relieve the Client of their obligations in this respect.

Intertek Testing Services NA Inc.
545 East Algonquin Road, Arlington Heights, IL 60005
Telephone 800-345-3851 or 847-439-5667 Fax 312-283-1672

Standard(s):	Explosive Atmospheres – Part 0: Equipment – General Requirements [UL 60079-0:2019 Ed.7+R:15Apr2020] Explosive Atmospheres - Part 11: Equipment Protection By Intrinsic Safety "i" [UL 60079-11:2013 Ed.6 +R:28Mar2014] Explosive Atmospheres - Part 0: Equipment - General Requirements [CSA C22.2#60079-0:2015 Ed.3] Explosive Atmospheres - Part 11: Equipment Protection by Intrinsic Safety "i" (R2018) [CSA C22.2#60079-11:2014 Ed.2] Nonincendive Electrical Equipment for Use in Class I and II, Division 2 and Class III, Divisions 1 and 2 Hazardous (Classified) Locations [UL 121201:2017 Ed.9+R:26Aug2019] Enclosures for use in Class II, Division 1, Groups E, F, and G Hazardous Locations [CSA C22.2#25:2017 Ed.4] Nonincendive Electrical Equipment For Use In Class I And II, Division 2 And Class III, Divisions 1 and 2 Hazardous (Classified) Locations [CSA C22.2#213:2017 Ed.3+U1;U2] Electrical Equipment for Measurement, Control, and Laboratory Use; Part 1: General Requirements>Valid without technical revision: 01Jan2022< [UL 61010-1:2012 Ed.3+R:29Apr2016] Safety Requirements for Electrical Equipment for Measurement, Control, and Laboratory Use Part 1: General Requirements [CSA C22.2#61010-1-12:2012 Ed.3+U1;U2;A1]
Product:	4 and 5 Digit Loop Powered Indicators and Loop Powered Rate Totaliser for use in: Class I Division 1 Groups A B C D T5 $-40^{\circ}\text{C} \leq T_a \leq +70^{\circ}\text{C}$ Class II Division 1 Groups E F G $-40^{\circ}\text{C} \leq T_a \leq +60^{\circ}\text{C}$ Class III Division 1 $-40^{\circ}\text{C} \leq T_a \leq +60^{\circ}\text{C}$ Class I Zone 0 AEx ia IIC T5 Ga $-40^{\circ}\text{C} \leq T_a \leq +70^{\circ}\text{C}$ Zone 20 AEx ia IIIC T80°C Da $-40^{\circ}\text{C} \leq T_a \leq +60^{\circ}\text{C}$ Ex ia IIC T5 Ga $-40^{\circ}\text{C} \leq T_a \leq +70^{\circ}\text{C}$ Ex ia IIIC T80°C Da $-40^{\circ}\text{C} \leq T_a \leq +60^{\circ}\text{C}$ and Class I Division 2 Groups A B C D T5 Class II Division 2 Groups F G Class III Division 2 $-40^{\circ}\text{C} \leq T_a \leq +70^{\circ}\text{C}$
Brand Name:	BEKA
Models:	BA304G, BA324G, BA354G.



LOOP POWERED INDICATORS AND TOTALISER WITH SEPARATELY POWERED BACKLIGHT

HAZARDOUS LOCATION

NON-HAZARDOUS LOCATION

See notes 1 & 3

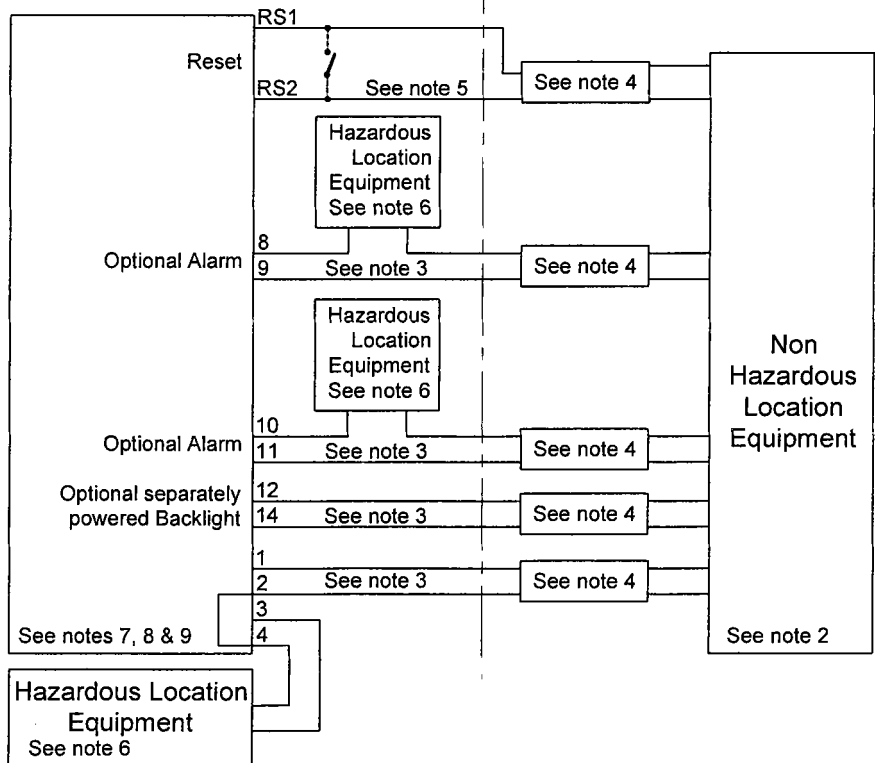
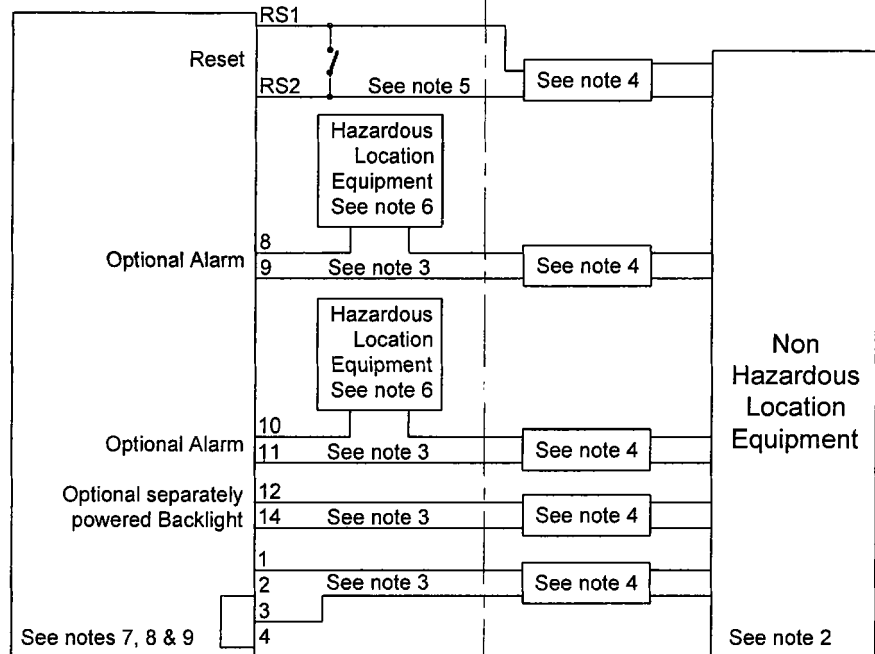

Appd.	
Ckd.	
Modification	
Date	
Iss.	

BEKA associates
 Hitchin England
 company confidential, copyright reserved.

Appd.	<i>[Signature]</i>
Ckd.	<i>[Signature]</i>
Modification	New drawing

Date	29.11 2016
Iss.	1

Title
 ETL Intrinsically Safe Control Drawing for
 BA304G, BA324G LOOP POWERED INDICATORS
 BA354G LOOP POWERED RATE TOTALISER

Drawn SQ	Checked OL	Scale -
Drawing No.		CI300-83
Sheet 1 of 5		



Iss.	1	Date	29.11 2016	Modification	New drawing	Ckd.	<i>[Signature]</i>	Appd.	<i>[Signature]</i>
Iss.		Date		Modification		Ckd.		Appd.	

BEKA associates
England
Hitchin
company confidential, copyright reserved.

LOOP POWERED INDICATORS AND TOTALISER WITH LOOP POWERED BACKLIGHT

HAZARDOUS LOCATION

NON-HAZARDOUS LOCATION

See notes 1 & 3

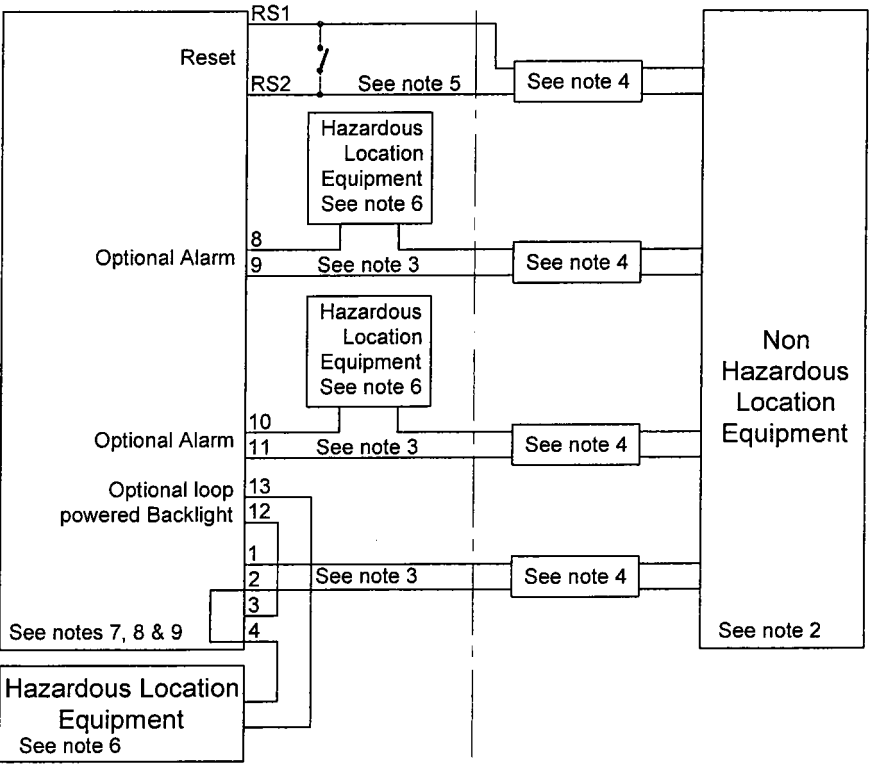
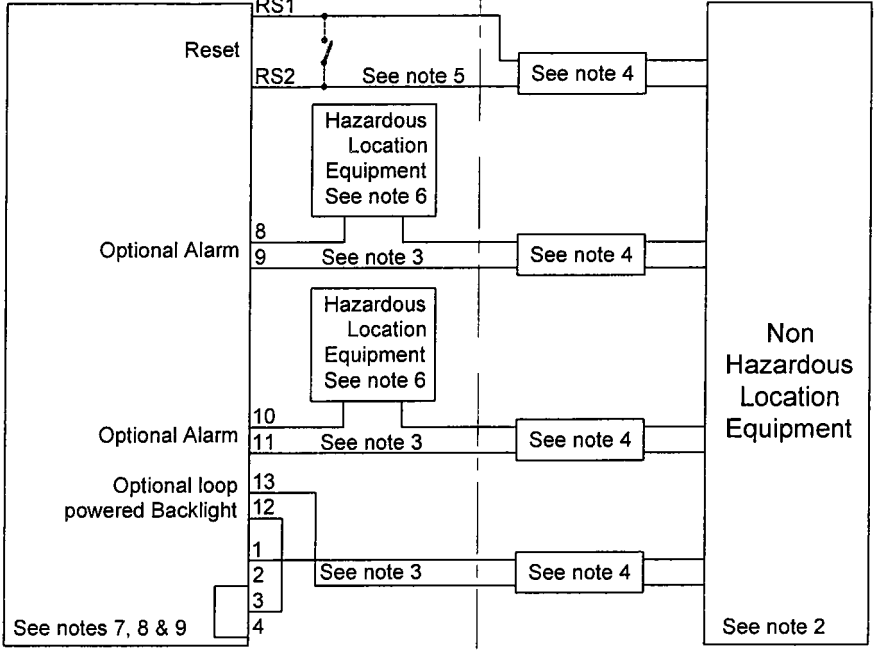

Title
ETL Intrinsically Safe Control Drawing for
BA304G, BA324G LOOP POWERED INDICATORS
BA354G LOOP POWERED RATE TOTALISER

Drawn	SQ	Checked	O.L	Scale	-
Drawing No.			CI300-83		
Sheet 2					

Iss.	1	Date	29.11 2016	Modification	New drawing	Ckd.		Appd.	
Iss.		Date		Modification		Ckd.		Appd.	

BEKA
Hitchin
associates
England
company confidential, copyright reserved.

6. Simple Apparatus as defined in the National Electrical Code ANSI/NFPA 70, or for installations in Canada by the Canadian Electrical Code C22.2
OR:

- Ui equal or greater than The highest Uo of the NRTL or CSA approved apparatus powering the loop.
- li equal or greater than The highest Io of the NRTL or CSA approved apparatus powering the loop.
- Pi equal or greater than The highest Po of the NRTL or CSA approved apparatus powering the loop.
- Lo of the NRTL or CSA approved apparatus powering the loop equal or greater than The sum of the cable inductances and the internal inductances Li of each NRTL or CSA approved apparatus in the loop.
- Co of the NRTL or CSA approved apparatus powering the loop equal or greater than The sum of the cable capacitances and the internal capacitances Ci of each NRTL or CSA approved apparatus in the loop.

7. Loop powered indicators and loop powered rate totalisers with coding and model numbers as shown in the table below.

'G' FIELD MOUNTING INSTRUMENTS

Type	Model Nos.	Division Marking	Zonal Marking	Ambient Temp.
Loop powered indicators Loop powered rate totaliser	BA304G BA324G BA354G	Gas: Class I Division 1 Groups A, B, C & D T5	Gas: Class I Zone 0 AEx ia IIC T5 Ga	-40°C to +70°C
		Dust: Class II Division 1 Groups E, F & G Class III Division 1	Dust: Zone 20 AEx ia IIC T80°C Da	-40°C to +60°C

8. **CAUTION** The BA304G and BA324G Indicators and the BA354G Rate Totaliser enclosures are manufactured from conducting plastic per Article 250 of the National Electrical Code.

Iss.	Date	Title	Drawn	Checked	Scale
			SQ	OL	-
			Drawing No.	C1300-83	
			Sheet 4		



Iss.	1	Date	29.11 2016	Modification	New drawing	Ckd.	<i>[Signature]</i>	Appd.	<i>[Signature]</i>
Iss.		Date		Modification		Ckd.		Appd.	

BEKA associates
Hitchin
England
company confidential, copyright reserved.

9. Safety parameters

4/20mA input terminals 1, 2, 3 & 4

- U_i = 30V
- I_i = 200mA
- P_i = 0.84W
- U_o = 1.1V
- I_o = 3mA
- P_o = 4.5mW

- C_i = 5.4nF
- L_i = 0.016mH
- C_o = 60.6nF
- L_o = 0.78mH

4/20mA input terminals 1, 2, 3, 4, 12 & 13 & loop powered backlight.

- U_i = 30V
- I_i = 200mA
- P_i = 0.84W
- U_o = 1.1V
- I_o = 3mA
- P_o = 4.5mW

- C_i = 5.4nF
- L_i = 0.016mH
- C_o = 60.6nF
- L_o = 0.78mH

Separately powered backlight terminals 12 & 14.

- U_i = 30V
- I_i = 200mA
- P_i = 0.84W

- C_i = 3.3nF
- L_i = 0.008mH
- C_o = 63nF
- L_o = 0.79mH

Alarm terminals 8, 9, 10 and 11

- U_i = 30V
- I_i = 200mA
- P_i = 0.84W
- U_o = 1.47V
- I_o = 1.0µA
- P_o = 2.2µW

- C_i = 0nF
- L_i = 0.008mH
- C_o = 66nF
- L_o = 0.79mH

Reset terminals RS1 & RS2
BA354G rate totaliser only.

- U_i = 30V
- I_i = 200mA
- P_i = 0.84W
- U_o = 6V
- I_o = 2.5mA
- P_o = 3.8mW

- C_i = 0nF
- L_i = 0.008mH
- C_o = 66nF
- L_o = 0.79mH

Title
ETL Intrinsically Safe Control Drawing for
BA304G, BA324G LOOP POWERED INDICATORS
BA354G LOOP POWERED RATE TOTALISER

Drawn SQ	Checked QL	Scale —
Drawing No. Sheet 5		CI300-83



LOOP POWERED INDICATORS & TOTALISERS WITH SEPARATELY POWERED BACKLIGHT

HAZARDOUS LOCATION

See note 3

NON-HAZARDOUS LOCATION

See note 1

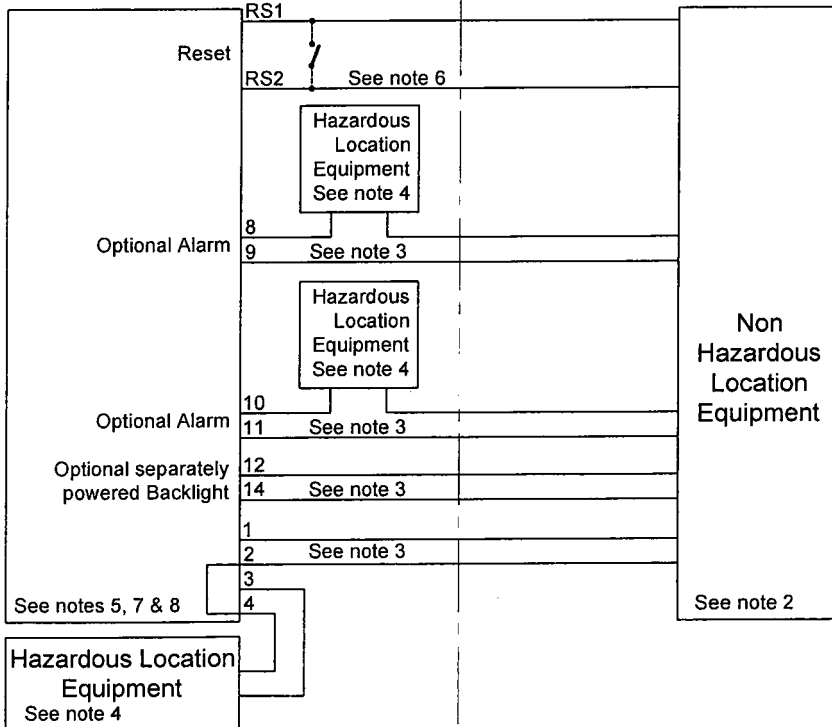
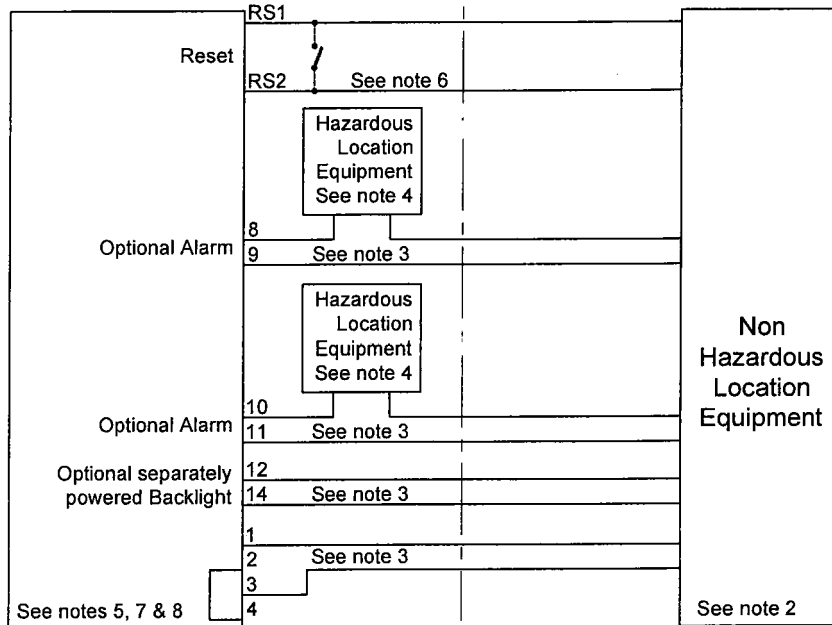

BEKA associates
 Hitchin
 England
 company confidential, copyright reserved.

Iss.	1	Date	29.11.2016	Modification	New drawing	Appd.	<i>[Signature]</i>	Ckd.	<i>[Signature]</i>	Appd.	
Iss.		Date		Modification		Appd.		Ckd.		Appd.	

Title
 ETL Nonincendive Control Drawing for
 BA304G and BA324G LOOP POWERED INDICATORS
 BA354G LOOP POWERED RATE TOTALISERS

Drawn	SQ	Checked	OL	Scale	-
Drawing No.		CI300-84			
Sheet 1 of 4					

LOOP POWERED INDICATORS AND TOTALISERS WITH LOOP POWERED BACKLIGHT

HAZARDOUS LOCATION
See note 3

NON-HAZARDOUS LOCATION
See note 1

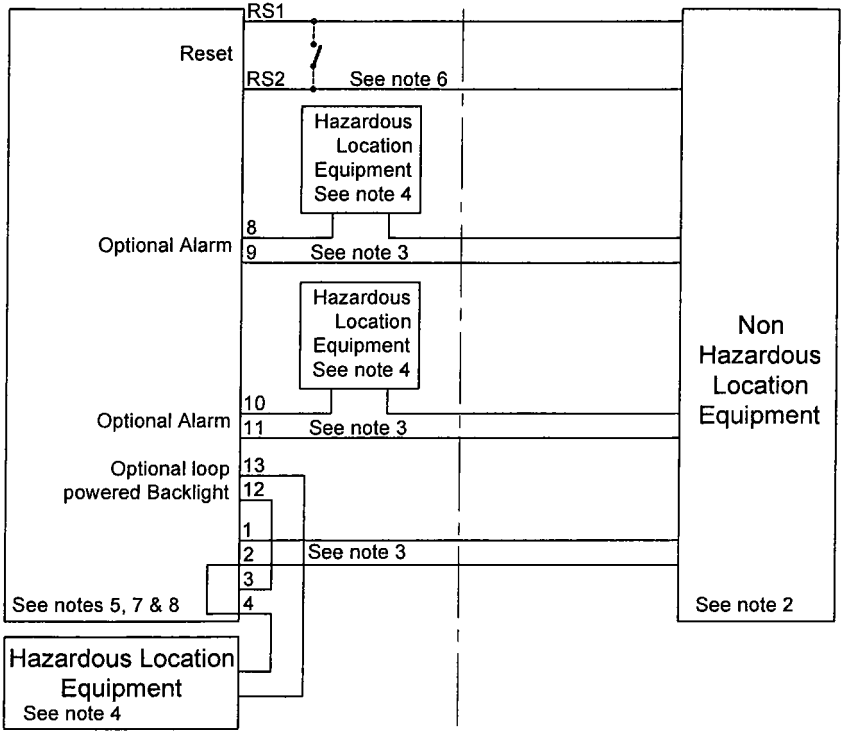
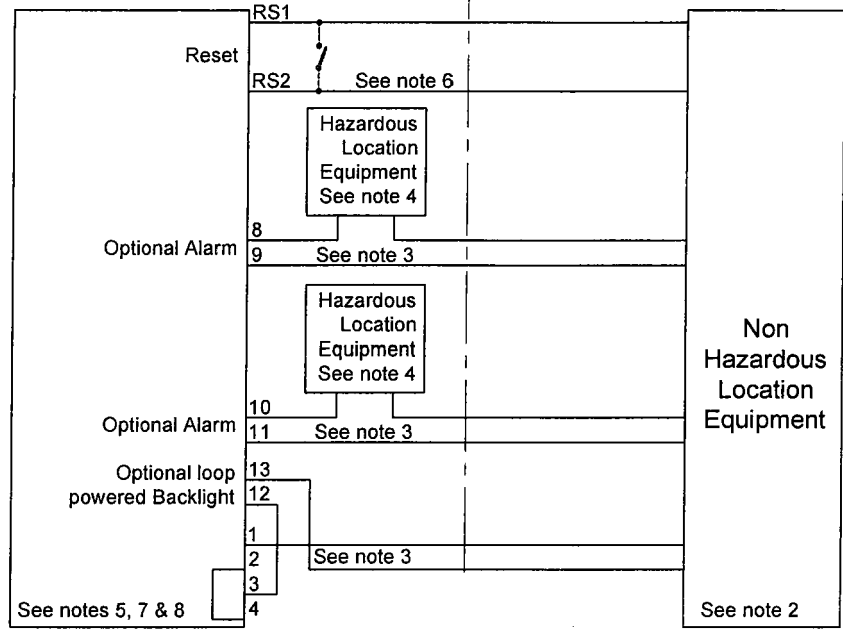

Iss.		Modification		Ckd.		Appd.	
Date							
BEKA associates England Hitchin company confidential, copyright reserved.							
Date	29.11 2016	Modification	New drawing	Ckd.	<i>[Signature]</i>	Appd.	<i>[Signature]</i>
Iss.	1						

Title
 ETL Nonincendive Control Drawing for
 BA304G and BA324G LOOP POWERED INDICATORS
 BA354G LOOP POWERED RATE TOTALISERS

Drawn	SQ	Checked	QL	Scale	-
Drawing No.			CI300-84		
Sheet 2					



Iss.	
Date	
Modification	
Ckd.	
Appd.	

BEKA **associates**
Hitchin England
company confidential, copyright reserved.

Iss.	1
Date	29.11 2016
Modification	New drawing
Ckd.	<i>[Signature]</i>
Appd.	<i>[Signature]</i>

Notes

1. The unclassified location equipment shall not use or generate more than 250V rms or 250V dc.
2. Nonincendive field wiring installations shall be in accordance with the National Electrical Code ANSI/NFPA 70. The Nonincendive Field Wiring concept allows interconnection of Nonincendive Field Wiring Apparatus with Associated Nonincendive Field Wiring Apparatus using any of the wiring methods permitted for unclassified locations. Installations in Canada shall be in accordance with the Canadian Electrical Code C22.2.
3. Classified location equipment shall be NRTL Approved Nonincendive Field Wiring Apparatus or simple apparatus as defined in ANSI/NFPA70. For Canadian installations classified location equipment shall be NRTL or CSA Approved Nonincendive Field Wiring Apparatus.
4. Simple Apparatus as defined in the National Electrical Code ANSI/NFPA 70, or for installations in Canada by the Canadian Electrical Code C22.2 or as defined in note 3.
5. Loop powered indicators and loop powered rate totalisers with model numbers and coding as shown in the tables below.

'G' FIELD MOUNTING INSTRUMENTS

Type	Model Nos.	Division Marking	Zonal Marking	Ambient Temp.
Loop powered indicators Loop powered rate totaliser	BA304G BA324G BA354G	Class I Division 2 Groups A, B, C & D T5 Class II Division 2 Groups F & G Class III Division 2	None	-40°C to +70°C

6. Reset terminals RS1 and RS2 are only fitted to the BA354G Rate Totaliser. They may be connected to Associated Nonincendive Field Wiring Apparatus, Nonincendive Field Wiring Apparatus or simple apparatus such as a single pole switch.
7. **CAUTION** The BA304G, BA324G Indicators and the BA354G Rate Totaliser enclosures are manufactured from conducting plastic per Article 250 of the National Electrical Code.

Iss.	Date	Title	Drawn	Checked	Scale
			SQ	QL	-
		ETL Nonincendive Control Drawing for BA304G and BA324G LOOP POWERED INDICATORS BA354G LOOP POWERED RATE TOTALISERS	Drawing No.		
			Sheet 3 C1300-84		

Iss.	Date	Modification	Ckd.	Appd.
1	29.11 2016	New drawing		
 BEKA Hitchin associates England company confidential, copyright reserved.				
Iss.	Date	Modification	Ckd.	Appd.

8. Safety parameters

4/20mA input terminals 1, 2, 3 & 4

$$\begin{aligned} I_i &= 200\text{mA} \\ U_o &= 1.1\text{V} \\ I_o &= 3\text{mA} \end{aligned}$$

Separately powered backlight terminals 12 & 14.

$$U_i = 30\text{V}$$

Reset terminals RS1 & RS2
BA354G and BA354NG rate totalisers only.

$$\begin{aligned} U_i &= 4.3\text{V} \\ U_o &= 6\text{V} \\ I_o &= 2.5\text{mA} \end{aligned}$$

4/20mA input terminals 1, 2, 3, 4, 12 & 13 & loop powered backlight.

$$\begin{aligned} I_i &= 200\text{mA} \\ U_o &= 1.1\text{V} \\ I_o &= 3\text{mA} \end{aligned}$$

Alarm terminals 8, 9, 10 and 11

$$\begin{aligned} U_i &= 30\text{V} \\ I_i &= 200\text{mA} \\ U_o &= 1.47\text{V} \\ I_o &= 1.0\mu\text{A} \end{aligned}$$

Title
ETL Nonincendive Control Drawing for
BA304G and BA324G LOOP POWERED INDICATORS
BA354G LOOP POWERED RATE TOTALISERS

Drawn SQ	Checked OL	Scale -
Drawing No.		CI300-84
Sheet 4		