

PINOUT	
PIN	SENSOR CONNECTION
1	SENSE
2	COMMON
3	PUMP
4	HEATER -
5	HEATER +

- NOTES:
- 20 AWG WIRES ADVISED FOR BOARD CONNECTION
 - WIRE LENGTH - 200 mm MAX
 - T90 < 4 SECONDS

UNLESS OTHERWISE SPECIFIED DIMENSIONS ARE IN MILLIMETERS STANDARD TOLERANCES: X X.X X.XX ±0.5 ±0.2 ±0.1 REQUIRED SURFACE FINISH - R _a 3.2 (N8) OR BETTER DEBURR AND BREAK SHARP EDGES ALL PARTS TO BE CLEAN AND FREE FROM DUST & OIL	MATERIAL: SENSOR - STAINLESS STEEL ISOLATOR - PTFE DRAWN BY: S.McCURRACH DRAWN ON: 02/04/2020	TITLE: MINIATURE OXYGEN SENSOR WITH ISOLATOR AND INTERFACE PCB O2S-FR-T3		
		THIRD ANGLE PROJECTION	DRAWING NO. O2S-XX-T3-PCB	REVISION: 2
		SCALE: 2:1	SHEET 1 OF 3	A3

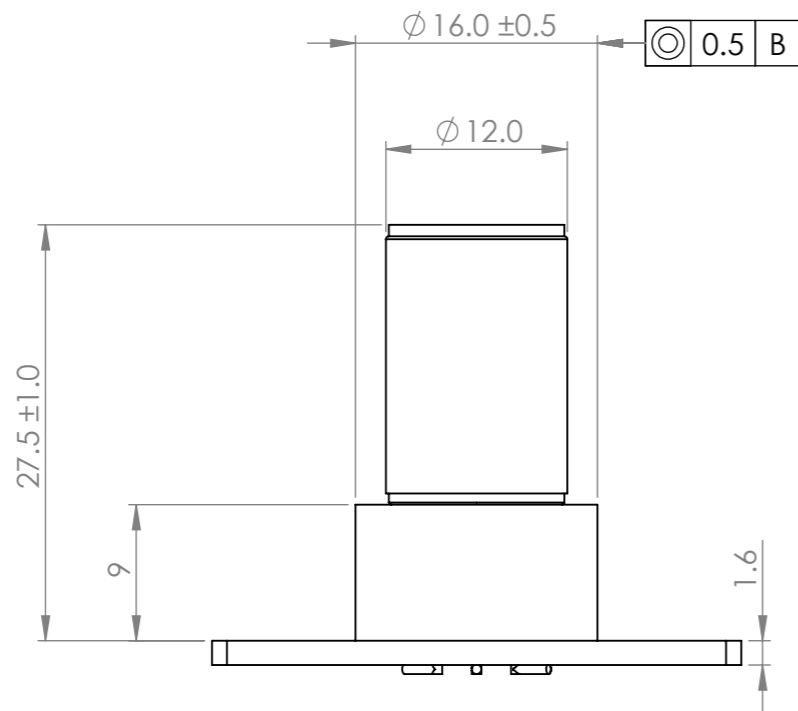
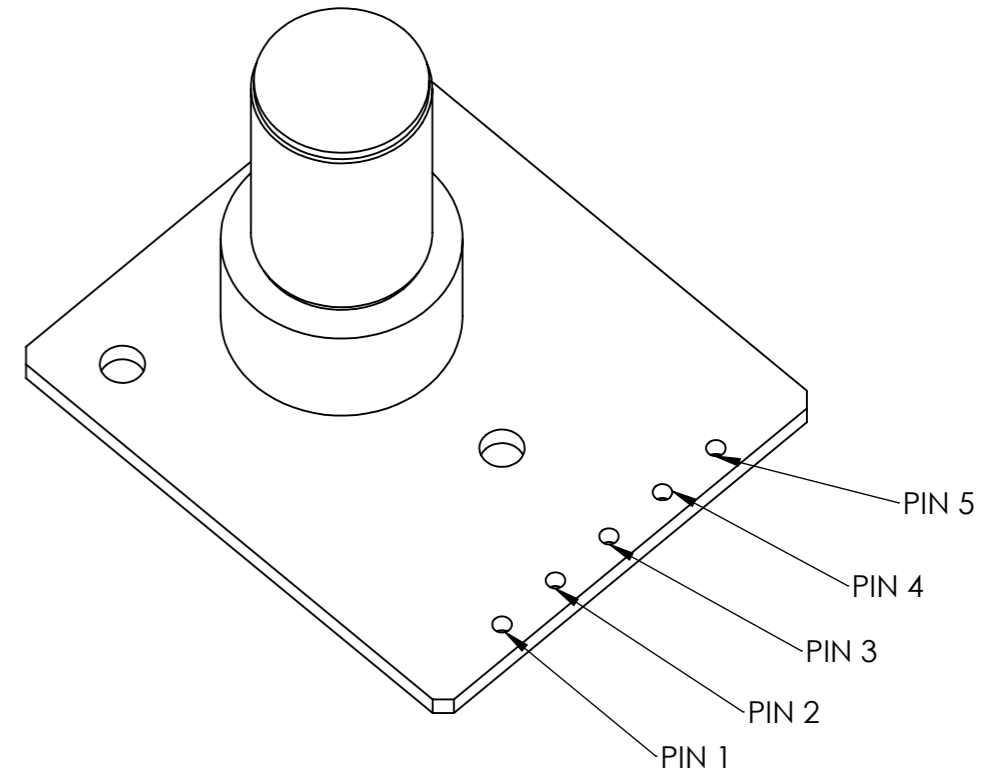
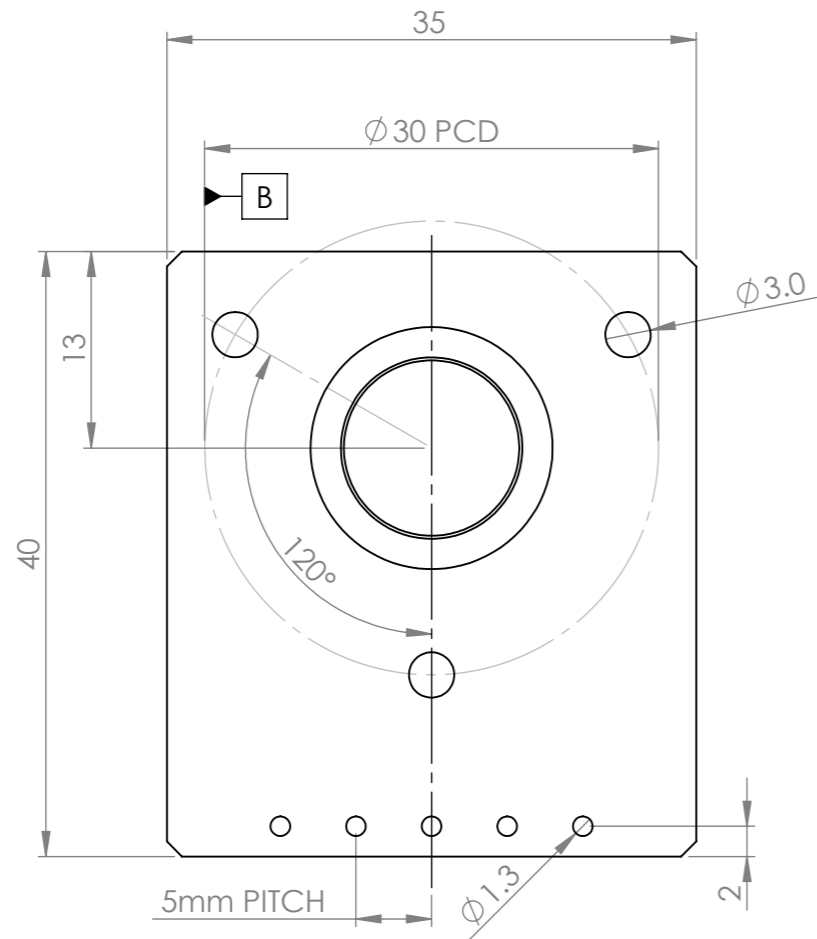

PINOUT	
PIN	SENSOR CONNECTION
1	SENSE
2	COMMON
3	PUMP
4	HEATER -
5	HEATER +

- NOTES:
- 20 AWG WIRES ADVISED FOR BOARD CONNECTION
 - WIRE LENGTH - 200 mm MAX
 - T90 <15 SECONDS

UNLESS OTHERWISE SPECIFIED DIMENSIONS ARE IN MILLIMETERS STANDARD TOLERANCES: X X.X X.XX ±0.5 ±0.2 ±0.1 REQUIRED SURFACE FINISH - R _a 3.2 (N8) OR BETTER DEBURR AND BREAK SHARP EDGES ALL PARTS TO BE CLEAN AND FREE FROM DUST & OIL	MATERIAL: SENSOR - STAINLESS STEEL ISOLATOR - PTFE DRAWN BY: S.McCURRACH DRAWN ON: 02/04/2020	TITLE: MINIATURE OXYGEN SENSOR WITH ISOLATOR AND INTERFACE PCB O2S-T3		
		THIRD ANGLE PROJECTION	DRAWING NO. O2S-XX-T3-PCB	REVISION: 2
		SCALE: 2:1	SHEET 2 OF 3	A3

8 7 6 5 4 3 2 1

F
E
D
C
B
A

F
E
D
C
B
A

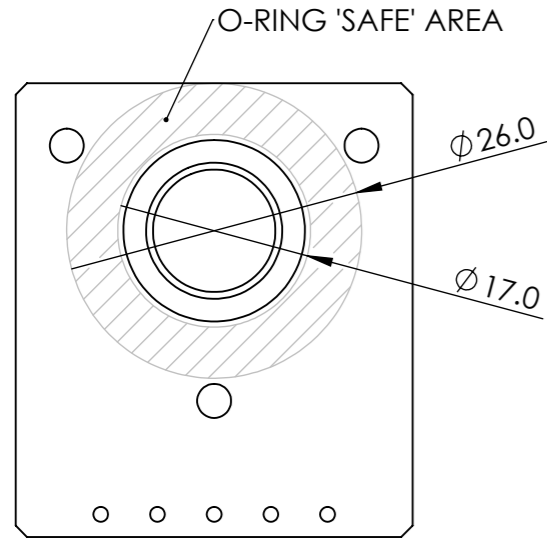

CLEARANCE FOR WIRES
MUST BE GIVEN

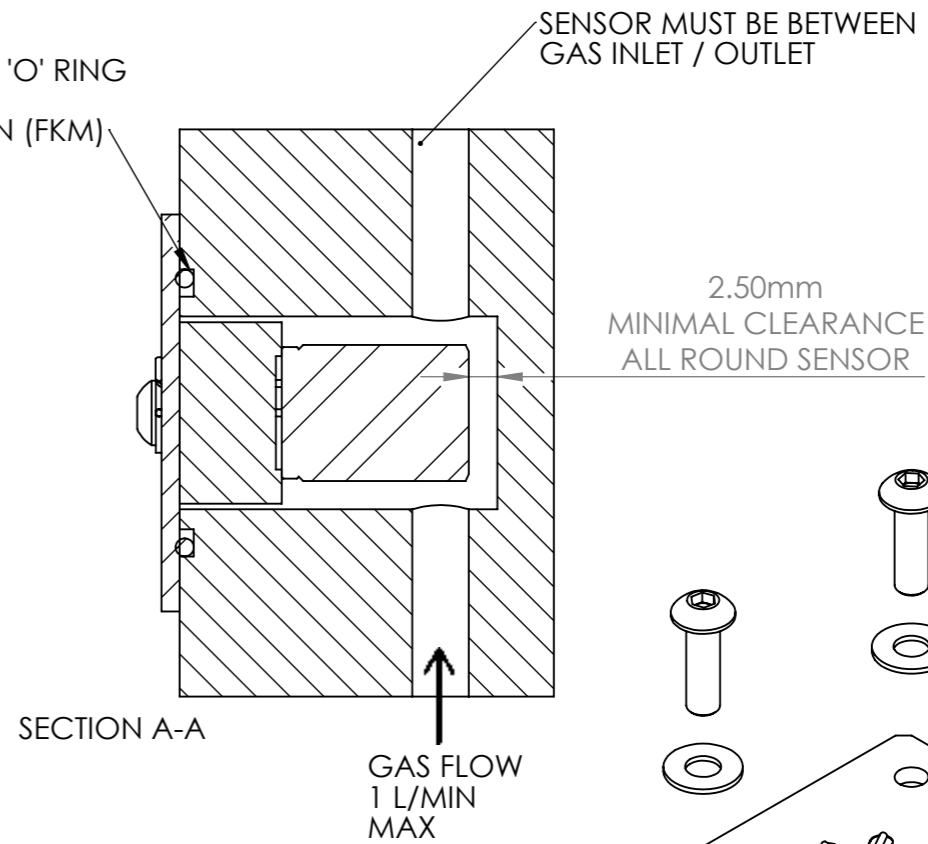
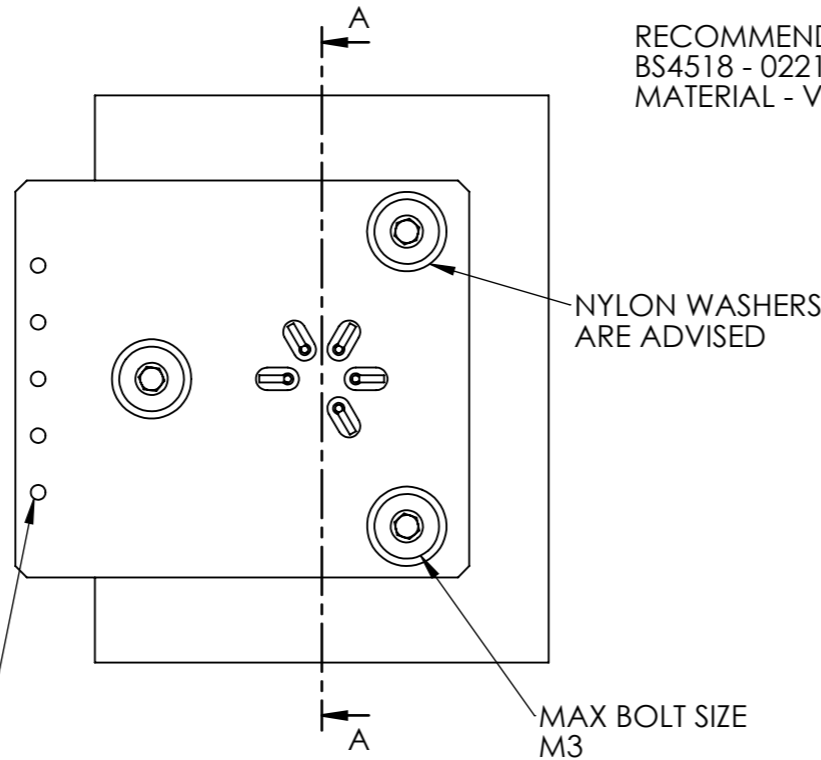

BLOCK FOR IMFORMATION PURPOSES ONLY
NOT SUPPLIED BY SST
RECOMMENDED MATERIALS:
STEEL, ALUMINIUM OR PTFE

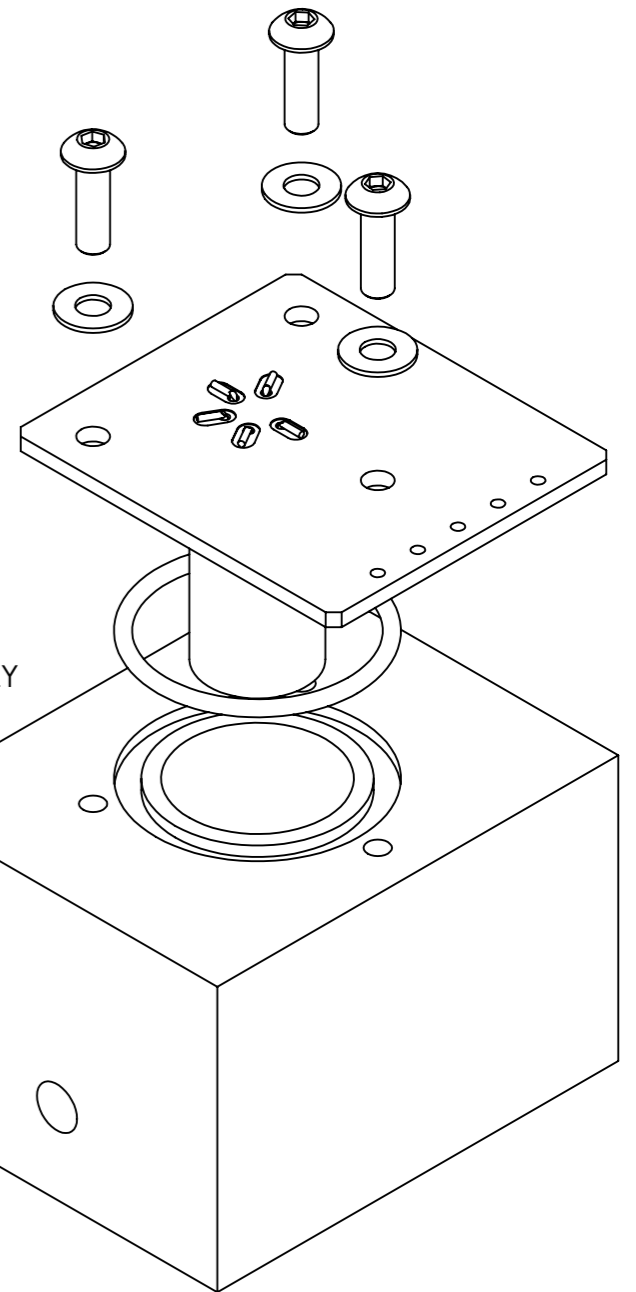

RECOMMENDED MOUNTING ANGLES
DURING OPERATION SENSOR SHOULD NOT BE MOUNTED WITH PCB ON TOP

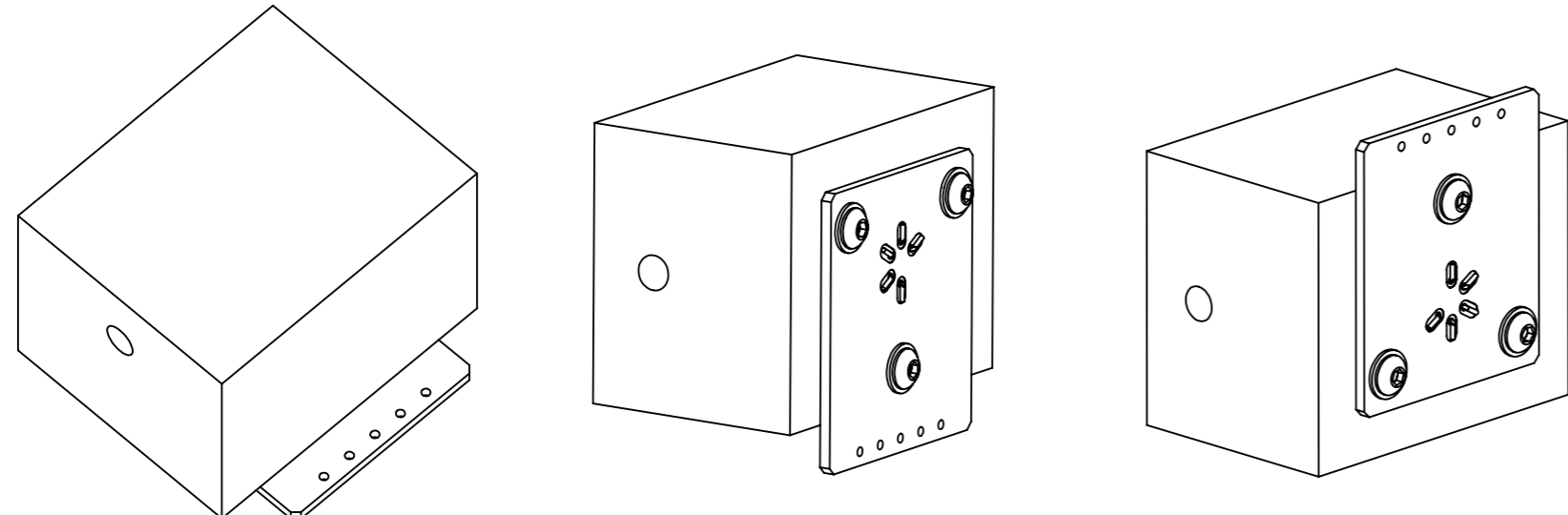

8 7 6 5 4 3 2 1

UNLESS OTHERWISE SPECIFIED DIMENSIONS ARE IN MILLIMETERS STANDARD TOLERANCES: X X.X X.XX ± 0.5 ± 0.2 ± 0.1 REQUIRED SURFACE FINISH - Ra3.2 (N8) OR BETTER DEBURR AND BREAK SHARP EDGES ALL PARTS TO BE CLEAN AND FREE FROM DUST & OIL	MATERIAL: SENSOR - STAINLESS STEEL ISOLATOR - PTFE	TITLE: MINIATURE OXYGEN SENSOR WITH ISOLATOR AND INTERFACE PCB RECOMMENDED MOUNTING	
	DRAWN BY: S.McCURRACH DRAWN ON: 02/04/2020	THIRD ANGLE PROJECTION	DRAWING NO. O2S-XX-T3-PCB
		SCALE: 3:2	SHEET 3 OF 3