

# MDLITE

MULTIDETEK-LITE

## USER'S MANUAL

COMPACT GAS CHROMATOGRAPH





*MultiDetek-Lite*

Compact Gas Chromatograph

USER'S MANUAL  
V1.1



## Table of Contents

Table of Contents .....	4
Table of Figures .....	5
1. Forewarning .....	6
2. Warranty and service policies .....	7
3. Declaration of conformity .....	10
4. Specifications .....	11
5. Installation .....	12
5.1. Storage and handling instructions .....	12
5.2. Analyzer application .....	14
5.3. Start-up .....	14
5.4. Shut-off .....	19
5.5. Typical installation .....	21
6. Hardware description .....	28
6.1. Detectors .....	28
6.2. Online Sensors .....	29
6.3. Motherboard .....	30
6.4. Sample gas proportional valve .....	39
6.5. Display with Touch Screen (7" 800x480) .....	39
6.6. Serial port .....	39
6.7. Relays .....	39
6.8. 4-20mA module .....	39
6.9. Diaphragm valve .....	40
6.10. Carrier gas electronic pressure regulator (LDepc) .....	40
6.11. Ovens and columns .....	41
7. Operation .....	42
7.1. User interface .....	42
7.2. Software procedures .....	48
8. Drawings & Schematics .....	59
8.1. Parts Identification .....	60
8.2. Back Panel Identification .....	61
8.3. Back Panel Pin Identification .....	62
8.4. Electrical schematic (block diagram) .....	63
8.5. Enclosure Dimensions & Panel Cutout .....	68
9. Maintenance and troubleshooting .....	69
9.1. Spare part list .....	69
9.2. Tools .....	70
9.3. Maintenance procedures .....	72
9.4. Troubleshooting .....	77

## Table of Figures

Figure 1: Boot up screen .....	15
Figure 2: Boot-up alerts .....	15
Figure 3: Oven setpoint.....	16
Figure 4: Operating Parameters .....	18
Figure 5: Typical Installation.....	22
Figure 6: Same source actuation .....	24
Figure 7: 2 sources of actuation .....	25
Figure 8: O2 doping .....	27
Figure 9: Type of Detectors .....	28
Figure 10: MultiDetek-Lite printed circuit board (PCB) .....	30
Figure 11: ACDC Board .....	31
Figure 12: Bus Board .....	31
Figure 13: Master Board .....	32
Figure 14: Plasma Board.....	32
Figure 15: Flow Board.....	33
Figure 16: Flow Board Output Connector .....	33
Figure 17: Multi Board .....	34
Figure 18: Multi Board Relay Connector.....	34
Figure 19: Multi Board 4-20mA output.....	35
Figure 20: 4-20mA Board.....	35
Figure 21: 4-20mA Board Outputs .....	36
Figure 22: 4-20mA Board Relay Outputs .....	36
Figure 23: Oven Board.....	37
Figure 24: TCD Board .....	37
Figure 25: FID Board.....	38
Figure 26: Solenoid proportional valve.....	39
Figure 27: Isothermal and programmable oven .....	41
Figure 28: Analysis menu .....	42
Figure 29: Settings menu .....	44
Figure 30: Calibration menu .....	45
Figure 31: Diagnostic menu .....	46
Figure 32: More menu.....	47
Figure 33: Parts Identification.....	60
Figure 34: Back Panel Identification.....	61
Figure 35: Back Panel Pin Identification .....	62
Figure 36: Electrical Schematic .....	63
Figure 37: Electrical Schematic [Master Board].....	64
Figure 38: Electrical Schematic [Oven Board] .....	65
Figure 39: Electrical Schematic [Plasma Board] .....	66
Figure 40: Electrical Schematic [Flow Board].....	67
Figure 41: HCD box.....	72
Figure 42: MultiDetek-Lite fan.....	73

## 1. Forewarning

Any user that wants to use the MultiDetek-Lite must read this manual. It contains valuable information to successfully operate this instrument. LDefek assumes that all operators have taken the time to read this information before installing, operating and troubleshooting this analyzer.

If any error is suspected by the reader, please contact LDefek. LDefek reserves the right to make any changes to subsequent editions of this document without prior notice to holders of this edition.

In no event shall LDefek be liable for any damages arising out of or related to this document or the information contained in it.

We want to thank you for choosing LDefek as your gas analyzer supplier.

---

## 2. Warranty and service policies

Goods and part(s) (excluding consumables) manufactured by the seller are warranted to be free from defects in workmanship and material under normal use and service for **twelve (12) months** after installation and start-up and not exceeding **eighteen (18) months** from shipment date. Consumable, chemical traps, O-rings, etc., are warranted to be free from defects in workmanship and material under normal use and service for a period of **ninety (90) days** from the date of shipment by the seller. Goods, part(s) proven by the seller to be defective in workmanship and/or material shall be replaced or repaired, free of charge, F.O.B. Seller's factory provided that the goods, part(s) are returned to Seller's designated factory, transportation charges prepaid, within the twelve (12) months after installation and start-up and not exceeding 18 months from shipment date. In the case of consumables, within the ninety (90) days period of warranty, a defect in goods, part(s) and consumable of the commercial unit shall not operate to condemn such commercial unit when such goods, part(s) and consumable are capable of being renewed, repaired or replaced.

The Seller shall not be liable to the Buyer, or any other person, for the loss or damagedirectly or indirectly, arising from the use of the equipment of goods, from breach of anywarranty, or any other cause.

### **ALL OTHER WARRANTIES, EXPRESSED OR IMPLIED ARE HEREBY EXCLUDED.**

IN CONSIDERATION OF THE HEREIN-STATED PURCHASE PRICE OF THE GOODS, THE SELLER GRANTS ONLY THE ABOVE-STATED EXPRESS WARRANTY. NO OTHER WARRANTIES ARE GRANTED INCLUDING, BUT NOT LIMITED TO, EXPRESS AND IMPLIED WARRANTIES OF MERCHANTABILITY AND FITNESSFOR A PARTICULAR PURPOSE.

THIS WARRANTY IS THE ONLY WARRANTY MADE BY LDETEK INC. FOR THE GOODS DELIVERED HEREUNDER, AND NO EMPLOYEE, REPRESENTATIVE OR OTHER PERSON OR ENTITY IS AUTHORIZED TO ASSUME FOR LDETEK INC ANY OBLIGATION OR LIABILITY BEYOND OR AT VARIANCE WITH THIS WARRANTY IN CONNECTION WITH THE SALE OF LDETEK PRODUCTS.

**Limitations of Remedy.** SELLER SHALL NOT BE LIABLE FOR DAMAGES CAUSED BY DELAY IN PERFORMANCE. THE SOLE AND EXCLUSIVE REMEDY FOR BREACH OF WARRANTY SHALL BE LIMITED TO REPAIR OR REPLACEMENT UNDER THE STANDARD WARRANTY CLAUSE. IN NO CASE, REGARDLESS OF THE FORM OF THE CAUSE OF ACTION, SHALL THE SELLER'S LIABILITY EXCEEDS THE PRICE TO THE BUYER OF THE SPECIFIC GOODS

MANUFACTURED BY SELLER GIVING RISE TO THE CAUSE OF ACTION. BUYER AGREES THAT IN NO EVENT SHALL SELLER'S LIABILITY EXTEND TOINCLUDE INCIDENTAL OR CONSEQUENTIAL DAMAGES. CONSEQUENTIAL DAMAGES SHALL INCLUDE BUT ARE NOT LIMITED TO, LOSS OF ANTICIPATED PROFITS,

---

LOSS OF USE, LOSS OF REVENUE, COST OF CAPITAL AND DAMAGE OR LOSS OF OTHER PROPERTY OR EQUIPMENT. IN NO EVENT SHALL THE SELLER BE LIABLE FOR PROPERTY DAMAGE AND/OR THIRD-PARTY CLAIMS COVERED BY UMBRELLA INSURANCE AND/OR INDEMNITY COVERAGE PROVIDED TO THE BUYER, ITS ASSIGNS, AND EACH SUCCESSOR INTEREST TO THE GOODS PROVIDED HEREUNDER.

**Major force.** The seller is not liable for failure to perform due to labour strikes or acts beyond the seller's direct control.

## SERVICE POLICY

1. If a product should fail during the warranty period, it will be repaired free of charge. For out-of-warranty repairs, the customer will be invoiced for repair charges at current standard labour and materials rates.
2. Customers who return products for repairs, within the warranty period, and the product is found to be free of defect, may be liable for the minimum current repair charge.
3. For parts replacement, the original part must be returned with the serial and model numbers of the analyzer. **NO PART WILL BE SHIPPED IF THE ORIGINAL IS NOT SENT BACK TO LDETEK INC.**

## RETURNING A PRODUCT FOR REPAIR

Upon determining that repair services are required, the customer must:

- Obtain an RMA (Return Material Authorization) number.
- Supply a purchase order number or other acceptable information.
- Include a list of problems encountered along with the name, address, telephone, and RMA number.
- Ship the analyzer in its original crating or equivalent. Failure to properly package the analyzer will automatically void the warranty.
- Every gas connection must be capped with appropriate metal caps. Failure to do so will automatically void the warranty.
- Write the RMA number on the outside of the box.
- Use an LDefetek-approved carrier. Also, the delivery must be sent to LDefetek facilities. LDefetek will not accept airport-to-airport delivery.
- LDefetek will not cover the transportation fees.

Other conditions and limitations may apply to international shipments.



## **PROPRIETARY RIGHTS**

Buyer agrees that any LDetek's software, firmware and hardware products ordered or included in the goods ordered are proprietary of LDetek. No change, modification, defacement, alteration, reverse engineering, neither software de-compilations nor reproductions of such software or hardware products, or disclosures of programming content to other parties are authorized without the express written consent of LDetek.

To maintain LDetek's trade secret and other proprietary protection of such software and firmware, such items are not sold hereunder but are licensed to the buyer.

LDetek Inc. reserves the right to interrupt all business relationships and warranty or service if there is any tentative from any customers to reverse engineering any of LDetek products or to tamper with any sealed module.

Trademarks and product identification as MultiDetek-Lite are the property of LDetek Inc. and shall be used only in connection with LDetek's products. No third party could remove or deface any model number or marks.

## 3. Declaration of conformity

### EU Declaration of Conformity



Manufacturer: LDetek Inc.  
Address: 990 Monfette E., Thetford Mines, QC G6G 7K6



declare, under our sole responsibility, on the date that it is placed on the market, the product(s):

#### MD Lite

to which this declaration relates, is/are in conformity with the latest technical requirements of the following EU directives and is in conformance with the relevant sections of the harmonised EN standard(s):

Low Voltage (LVD) - 2014/35/EU  
EN 61010-1:2010+A1:2019+AC:2019-04

Electromagnetic Compatibility (EMC) - 2014/30/EU  
EN 61326-1:2013 – *Class A (emissions) and Industrial Locations (immunity)*

Restriction of the Use of Certain Hazardous Substances (RoHS2) - 2011/65/EU+(EU)2015/863  
EN IEC 63000:2018



Dany Gagne, CTO  
06 03 2025,  
Thetford Mines, QC

## 4. Specifications

Gas Chromatography Detector:	<ul style="list-style-type: none"> <li>• PED / TCD / FID</li> </ul>
Online Detectors:	<ul style="list-style-type: none"> <li>• Quartz Crystal Microbalance / Electrochemical / Zirconia</li> </ul>
Standard features:	<ul style="list-style-type: none"> <li>• 7" touchscreen display</li> <li>• LAN/Web control</li> <li>• Self-diagnostic system with maintenance planning</li> <li>• Isothermal ovens for GC columns (up to 3x in one unit)</li> <li>• Electronic flow control regulators for carrier &amp; sample gases</li> <li>• 4-20 mA output per impurity (up to 8 outputs)</li> <li>• Alarm Historic</li> <li>• Digital system output for remote monitoring (dry relay contact)</li> </ul>
Options:	<ul style="list-style-type: none"> <li>• Serial communication (RS232/485) / Profibus / Modbus / Ethernet</li> <li>• Integrated stream selector system</li> <li>• Digital inputs for remote starting</li> <li>• Analog inputs for connecting external instruments</li> <li>• Remote control for stream selector (LDGSS)</li> <li>• Built-in online sensor module for trace moisture: Quartz Crystal (ppb/ppm) or Ceramic (ppm)</li> <li>• Built-in online sensor module for trace oxygen: Electrochemical (ppm) or Zirconia (ppm)</li> </ul>
Gas connections:	<ul style="list-style-type: none"> <li>• 1/8" or 1/4" face seal or compression fittings</li> </ul>
Carrier pressure:	<ul style="list-style-type: none"> <li>• 100 PSIG (other carrier pressure available on request)</li> </ul>
Operating ambient temperature range:	<ul style="list-style-type: none"> <li>• 5 °C - 45 °C</li> </ul>
Calibration gas:	<ul style="list-style-type: none"> <li>• 50% to 90% of the full scale</li> </ul>
Sample pressure:	<ul style="list-style-type: none"> <li>• 5 to 30 PSIG (other pressures available on request)</li> </ul>
Supply:	<ul style="list-style-type: none"> <li>• 115 VAC, 50 – 60 Hz or 220 VAC, 50 – 60 Hz</li> </ul>
Power consumption:	<ul style="list-style-type: none"> <li>• Maximum 250 Watts</li> </ul>
Repeatability:	<ul style="list-style-type: none"> <li>• Three times the percentage of deviation (3*CV %) of each component has to be smaller than 5% on ten consecutive cycles</li> </ul>
Accuracy:	<ul style="list-style-type: none"> <li>• Better than +/- 1% error or LDL whichever is higher</li> </ul>
LDL:	<ul style="list-style-type: none"> <li>• 3 times the noise level</li> </ul>
LOQ:	<ul style="list-style-type: none"> <li>• 3 times LDL value</li> </ul>
Long-term stability & drift:	<ul style="list-style-type: none"> <li>• Three times the percentage of deviation (3*CV %) of each component has to be smaller than 10% for 8 hours</li> </ul>
Linearity:	<ul style="list-style-type: none"> <li>• For 5 points within the measuring range, the linear curve must have its R2 at a value between 0.998 and 1.00</li> </ul>

---

## 5. Installation

### 5.1. Storage and handling instructions

#### 5.1.1. Analyzer storage instructions

In order for this product to be functional upon installation it should be stored in accordance with the guidelines below:

- The product must be housed in a sheltered area, out of direct sunlight and rain.
- The product should be stored to minimize the possibility of sitting in ground water.
- The temperature within the storage environment should be maintained between +10 and +30 °C (50 and +85 °F).
- The humidity within the storage environment must be 10 to 95 %RH
- The storage environment must not expose the analyzer to any corrosive elements.
- All electrical and process connections should remain disconnected and capped.
- All protective coatings should remain in place until installation.
- Any documentation supplied with the product should be removed from the packing crate and stored elsewhere to protect its integrity.
- Storing the product for longer than 6 months could affect the time required for start-up.

#### 5.1.2. Detector cautions

The MultiDetek-Lite utilizes multiple detection techniques that have been well-established in the industry for many years, including Plasma Emission Detector (PED), Flame Ionization Detector (FID), Thermal Conductivity Detector (TCD), and others upon request.

##### **PED**

The PED operates on the principle of spectroscopic emission. A pure quartz cell is placed in an electromagnetic field generated by a specific high-intensity generator. This electromagnetic field creates plasma, which emits light at different wavelengths. By using appropriate optical filters, the detector can detect the desired impurities. One of the key benefits of the PED is its ability to offer a selective mode based on the spectral line used to measure specific impurities, providing both selectivity and sensitivity.

To prevent the quartz cell from cracking, it is important to maintain **atmospheric pressure in the analyzer vent**. Any back pressure on the detector vent connection can cause damage and require the replacement of the plasma detector module. However, the PED is a low-maintenance device that does not require regular upkeep.

##### **FID**

The FID is a commonly used gas chromatography detector for the analysis of organic compounds. It operates on the principle that when organic molecules pass through a hydrogen flame, they are ionized, creating a current that is measured. The magnitude of the current is proportional to the concentration of the organic compound. The FID requires a

---

fuel gas (usually hydrogen) and an oxidant gas (usually air) to sustain the flame. The FID is highly sensitive to most organic compounds, making it a popular choice for a wide range of applications.

### **TCD**

A TCD is a type of detector commonly used in gas chromatography. It operates by measuring changes in the thermal conductivity of the carrier gas flowing through the detector caused by the presence of analytes. The TCD consists of a sensing element and two reference elements, all of which are housed in an oven. When the carrier gas passes through the sensing element, it transfers heat away from a filament that is heated to a constant temperature. As the analytes pass through the sensing element, they displace the carrier gas, causing a decrease in thermal conductivity and a corresponding increase in filament temperature. This temperature change is detected and measured by the reference elements, allowing for the quantification of the analytes. The TCD is highly selective and sensitive and is commonly used for the detection of non-volatile or semi-volatile compounds, such as gases, inorganic compounds, and some organic compounds.

---

## 5.2. Analyzer application

The MultiDetek-Lite is specifically designed for analyzing impurities and samples as outlined in the instrument's specification sheet. Using this instrument with any **other gas type may cause damage** to the analyzer. To ensure safe and proper use, refer to the "Operating Parameters" document that accompanies the unit. It is important to note that the GC is not intended for use in hazardous areas.

## 5.3. Start-up

To ensure the proper start-up of the MultiDetek-Lite, it is important to follow the steps below. All LDefek products are carefully packaged in a sturdy cardboard box, and each instrument is accompanied by a USB drive containing relevant documentation. If you require any assistance, please do not hesitate to contact us at [support@ldetek.com](mailto:support@ldetek.com).

1. Carefully unpack the instrument from the box and inspect it to ensure that it is in good condition and has not been damaged during shipping.
2. Locate the documents, USB drive, fuse kit and power cables.
3. Choose whether to install the unit on a table or mount it on a rack. If mounting on a rack, refer to section 8 for panel cutout drawings and to determine the required space.
4. Carefully install the instrument in its designated location and inspect it to ensure that it is in good condition and undamaged. Before connecting the carrier gas lines to the MultiDetek-Lite, it is necessary to install and purge the lines. Please consult the "Operating Parameters" document included on the USB drive for information on the appropriate carrier gas type, pressure and gas line connections.
5. The carrier gas purifier (LDP1000) must be started first. To install it, follow the steps in the LDP1000 user's manual.
6. After the LDP1000 has been purged, connect its outlet to the back panel connection of the MultiDetek-Lite named "Carrier Inlet". Before connecting the carrier, it is very important to remove all the caps installed on the MultiDetek-Lite back panel. **Any back pressure on the detector vent connection can cause damage and require the replacement of the plasma detector module.**
7. Once the gas lines have been purged and the carrier gas is connected, connect the power source. Check the "Operating Parameters" document to verify that the voltage is correct (either 120VAC or 240VAC), and make sure that the voltage indicated on the red indicator of the power inlet module on the back panel matches the voltage of the power source. **Using the wrong voltage source can cause severe damage to the instrument.**
8. Turn ON the unit by switching on the back panel switch and wait for the unit to boot. The MultiDetek-Lite works within a Linux-based environment. The software will start automatically after the start-up. After each boot-up, the chromatogram screen shown below will appear.

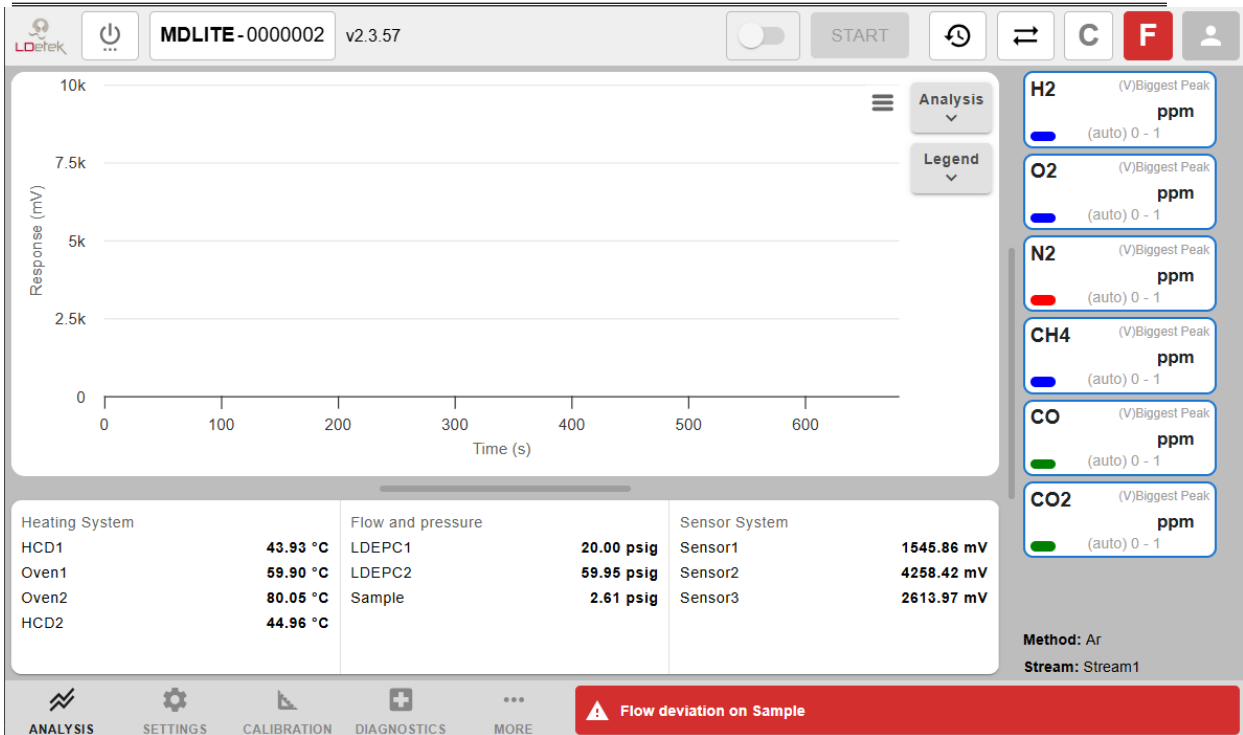

Figure 1: Boot up screen

- Before proceeding, it is essential to resolve all active alerts, except for "Flow deviation on Sample" and "Low flow on Sample". To view the list of active alerts, double-click on the red alert bar to open the alert menu.

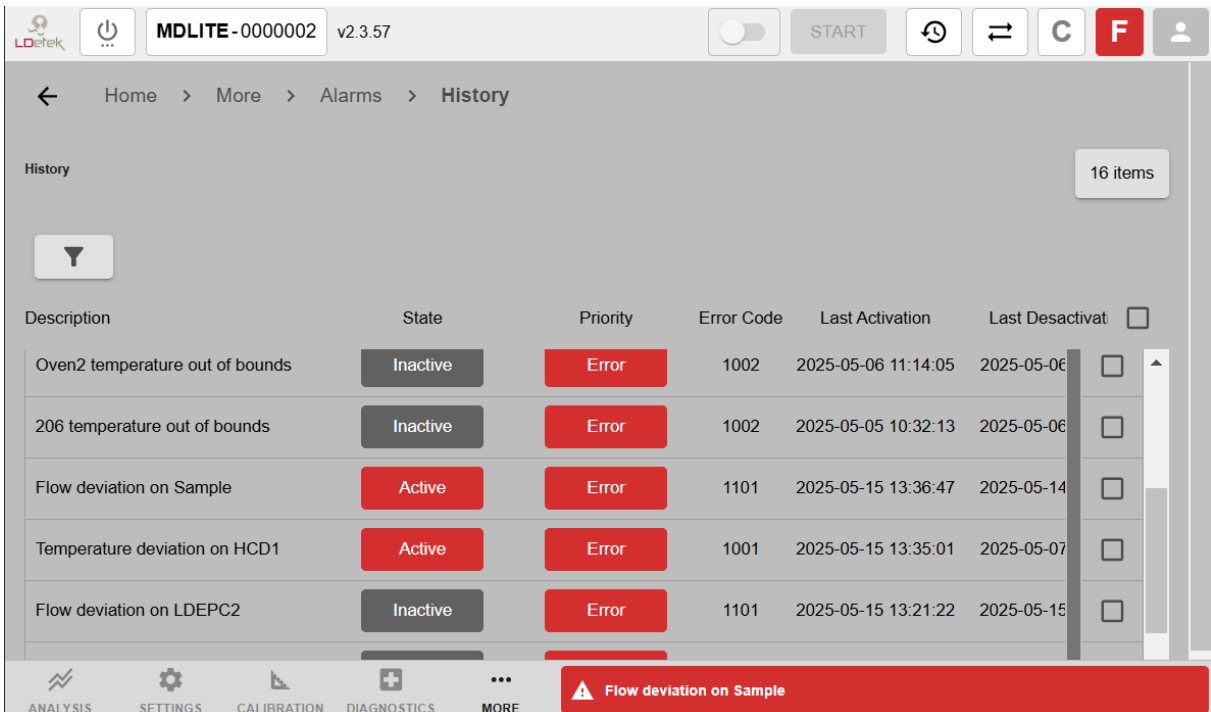

Figure 2: Boot-up alerts

Below are the principal alerts that you may encounter:

**Temperature deviation:** This type of alert is normal during initial start-up and will typically resolve itself after a few minutes as the ovens and HCD warm up. However, if the alert persists and no temperature change occurs, it may indicate a problem that requires further attention. To check the setpoint for each module, refer to the "Operating Parameters" document or go to the settings menu (Setting>>Oven>>Oven# or Settings>>HCD>>HCD#). Then, check the setpoint value. If the alert remains active after a few minutes, please contact LDeftek support for further assistance.

Hardware		HCD	
Enable this hardware		<input checked="" type="checkbox"/>	
P Gain	<input type="text" value="60"/>	I Gain	<input type="text" value="0.3"/>
D Gain	<input type="text" value="0"/>	Low Limit	<input checked="" type="checkbox"/> <input type="text" value="-100"/> °C
High Limit	<input checked="" type="checkbox"/> <input type="text" value="500"/> °C	Temp. Dev.	<input checked="" type="checkbox"/> <input type="text" value="3"/> °C
Setpoint	<input type="text" value="45"/> °C	Sampling Time	<input type="text" value="1"/> s

Figure 3: Oven setpoint

**Flow deviation on LDepc #:** This alert may appear after the initial start-up and can take a few minutes to disappear as each LDEPC must stabilize to its setpoint. The setpoints for each LDEPC are listed in the document "Operating Parameters," or can also be seen from the settings menu (Settings>>Flow>>LDEPC#). Check the value beside "Setpoint" to confirm it. If the alert persists after a few minutes, ensure that the inlet pressure is set to the value specified in the "Operating Parameters" document (typically 100 psig) and that there are no restrictions in the carrier gas line between the source and the analyzer's carrier inlet. If the above checks do not resolve the alert, please contact LDeftek support for further instructions.

Low flow on Sample: This alert will typically resolve automatically within a few minutes. During initial start-up, the sample proportional valve needs some time to stabilize. The setpoint for the sample flow can be found in the document "Operating Parameters". You can also check the sample setpoint in the settings menu (Settings>>Flow>>Sample). If the alert persists and no flow change is detected after a few minutes, please verify that the sample pressure is set to the value specified in the document "Operating Parameters" (typically 5-30 psig). Additionally, make sure that the right stream is selected, and finally, ensure that there are no obstructions between the sample source and the analyzer's sample inlet. If the alert remains active after these checks, please contact LDefek support for further assistance.

Detector # off: This alert may be resolved automatically after a few minutes. It is the time required for the detectors to stabilize and purge after the initial start-up. Once the LDEPC reaches their setpoints and a partial purge is achieved, the detectors will turn on automatically. To confirm the setpoints for each sensor, refer to the document "Operating Parameters". If the alert persists after a few minutes, please ensure that the LDEPC is functioning properly, and the carrier inlet pressure is set to the value indicated in the document "Operating Parameters". Additionally, make sure that there are no obstructions in the carrier gas flow path. If you still have an active "Detector # off" alert after confirming the above steps, please contact LDefek support for further instructions.

10. After resolving all active alerts, except for "Flow deviation on Sample" and "Low flow on Sample", the system must purge. A partial purge will take about 2-3 hours, and a good purge will take 12-24 hours depending on the system configuration. Note that for ppb systems with ranges of measurements below 1000 ppb, the purge may take 2-3 days.

To ensure that the system is well purged, you can compare the sensor voltages with the values specified in the "Operating Parameters" document. The current sensor values can be seen at the bottom-right of the chromatogram menu. The rule of thumb is to have signals between +/-25% of the values specified in the "Operating Parameters". The number of sensors depends on the MultiDetek-Lite's configuration. The figure below shows an example of a voltage chart found in the "Operating Parameters" document.

The sensor voltage values are indicated in the "Voltage" column of Figure 4.

Sensor (4)						
Name	List Order	Communication ID	Enable	Hardware	Components	Voltage
Sensor1	1	4	yes	Digital Plasma1.Sensor1	N2	681.9 mV
Sensor2	2	5	yes	Digital Plasma1.Sensor2	CH4	613.26 mV
Sensor3	3	6	yes	Digital Plasma2.Sensor1		471.97 mV
Sensor4	4	7	yes	Digital Plasma2.Sensor2	Ar	434.74 mV

Figure 4: Operating Parameters

11. Once the sensor voltages are within +/- 25% of the values shown in the "Operating Parameters" document, you can connect the calibration gas cylinder (span) to the system. When selecting a span gas cylinder, ensure that the concentration range for each impurity is within 50% to 90% of the full-scale range. Additionally, the balance gas of the cylinder should match the carrier gas or sample gas.

For example, if the MultiDetek-Lite is configured to measure 0-10ppm Ar and 0-50ppm N2 in Oxygen using Helium as the carrier gas, a certified span gas with a concentration range between 5-9ppm Ar and 25-45ppm N2 in Helium or Oxygen can be used. It is recommended to use the same balance gas as the carrier gas, as it simplifies troubleshooting.

Depending on the system configuration, the span gas cylinder must be connected to the appropriate inlet to calibrate the system. If the system has an integrated stream selector, the span gas must be connected to the span inlet. Otherwise, it should be connected to the sample inlet. Make sure to set the span gas pressure according to the values indicated in the "Operating Parameters" document. Once the span gas is connected, the "Sample Low Flow" alert should disappear. It might be required to select the span stream from the chromatogram menu. If needed refer to the section 7.2.3. When the alerts are all resolved, the red alert bar on the bottom will automatically disappear.

---

Once the sample lines are properly purged, simply start a cycle from the chromatogram menu. At the end of the analysis, it is important to look at the chromatogram to make sure all peak(s) fit completely in their respective window(s). If some peaks aren't perfectly integrated into their respective window, restart the analysis several times. If the issue persists, it is recommended to send the machine file (.ldb) to LDeTek support for further instructions. Refer to section 7.2.7 for further details on Machine file exporting.

During shipping, the system may experience vibrations that can lead to changes in its properties, including retention time. If this occurs and peaks no longer fit within their integration windows, LDeTek experts can analyze the machine file and help modify the parameters to correct the issue.

12. When all peaks are within their integration window, the span calibration of the system can be done. Refer to section 7.2.5. for details about calibration.
13. After the calibration, the system can be switched to the process/sample gas and is ready for normal operation.

#### **5.4. Shut-off**

During normal operation, the MultiDetek-Lite must always be purged with carrier gas. Leaving the system without carrier gas may result in air contamination that could damage the analyzer permanently.

If the system needs to be stopped, the connections on the back panel must be capped. Make sure that the carrier gas is closed before capping the analyzer because **any back pressure to the detector vent connections will damage the plasma detector modules**. Refer to the steps below to ensure the proper shut-off of the unit:

1. In the software, make sure you are in Admin mode. If needed, refer to section 7.2.1.
2. Once in admin mode, click on the power button in the top-left corner. A window will pop up asking you if you want to restart or power off the system. Click on "Shutdown" and the device will turn OFF.
3. Close the sample gas supply by closing the cylinder or any valve that controls it.
4. Disconnect the sample inlet and sample outlet tubes from the analyzer back panel.
5. If needed, repeat steps 4 and 5 for span gas, and O<sub>2</sub> doping gas.
6. Decrease the carrier gas pressure to 20 psi and disconnect the carrier inlet tube from the analyzer back panel.
7. Put a male cap over the carrier inlet tube that was removed.

8. If the actuation gas is coming from the same source as the carrier gas, repeat steps 7 and 8 for the actuation gas inlet.
9. Remove all the remaining vents tubes on the back panel.
10. Install all the caps on the MultiDetek-Lite back panel.
11. Power OFF the LDP1000 by moving its power switch to OFF and then, remove the power cable.
12. Wait until the LDP1000 reaches the ambient temperature (about 2 hours).
13. Remove the tube connected at the outlet connection of LDP1000 and quickly cap the outlet connection of the purifier with a male or female cap. The type of caps depends on your LDP1000 model.
14. Remove the tube connected at the inlet connection of LDP1000 and quickly cap the inlet connection of the purifier with a female cap. The type of caps depends on your LDP1000 model.
15. Shut down the carrier gas source on the cylinder or tank.

---

## 5.5. *Typical installation*

### 5.5.1. Carrier gas

For the GC to operate properly, it is very important to give the best reference baseline to ensure the reliability and durability of the internal components. In this section, we will explain the importance of the continuous supply of carrier gas and its purity.

Figure 5 shows a typical installation of a MultiDetek-Lite. The carrier gas is supplied with an automatic switchover system (LDASS). This system also includes 2 inlets integrated stream selector (ISS). This allows the operator to switch between the sample and span gas. As shown in Figure 6, some installations might use an LDGSS instead of an ISS. On these installations, streams are connected to the LDGSS before going to the MultiDetek-Lite. Figure 5 also shows that an Oxygen doping system has been added for trace O<sub>2</sub> measurement. For more details, please refer to section 5.5.3 O<sub>2</sub> doping. Generally speaking, Argon, Helium or Nitrogen are used as carrier gas. Their physical properties make these gases the top choices for use in gas chromatography. However, the purity of these carriers is critical to ensure stable, accurate and reliable results.

The carrier gas is used to carry the sample gas to the chromatographic columns and gas detectors, therefore, the purity of the carrier gas is very important. To maintain the equilibrium inside the analyzer, we must start with a certified carrier gas with a purity of grade 5 or higher (>99.999%). This grade is certified to have a maximum concentration of 10 ppm of total impurities. The grade 5 carrier is then purified by a filter-type heated gas purifier (LDP1000). Starting from grade 5, the outlet purity of the purifier will be 99.999999% (grade 8.0). Some applications might require different grades of carrier gas. Please refer to the document "Operating Parameters" to see what the specification is for your analyzer.

As demonstrated in Figure 5, an automatic switchover system is required to automatically switch the carrier gas cylinder when the pressure reaches 200-250psig. This automatic switchover system ensures that there is no carrier flow interruption in the system. Once the system is switched to the backup bottle, it is the responsibility of the user to replace the empty bottle. The lifetime of a carrier bottle is application dependent but a small to mid-size GC requires a 50 litres (9 cubic meters) bottle once a month.

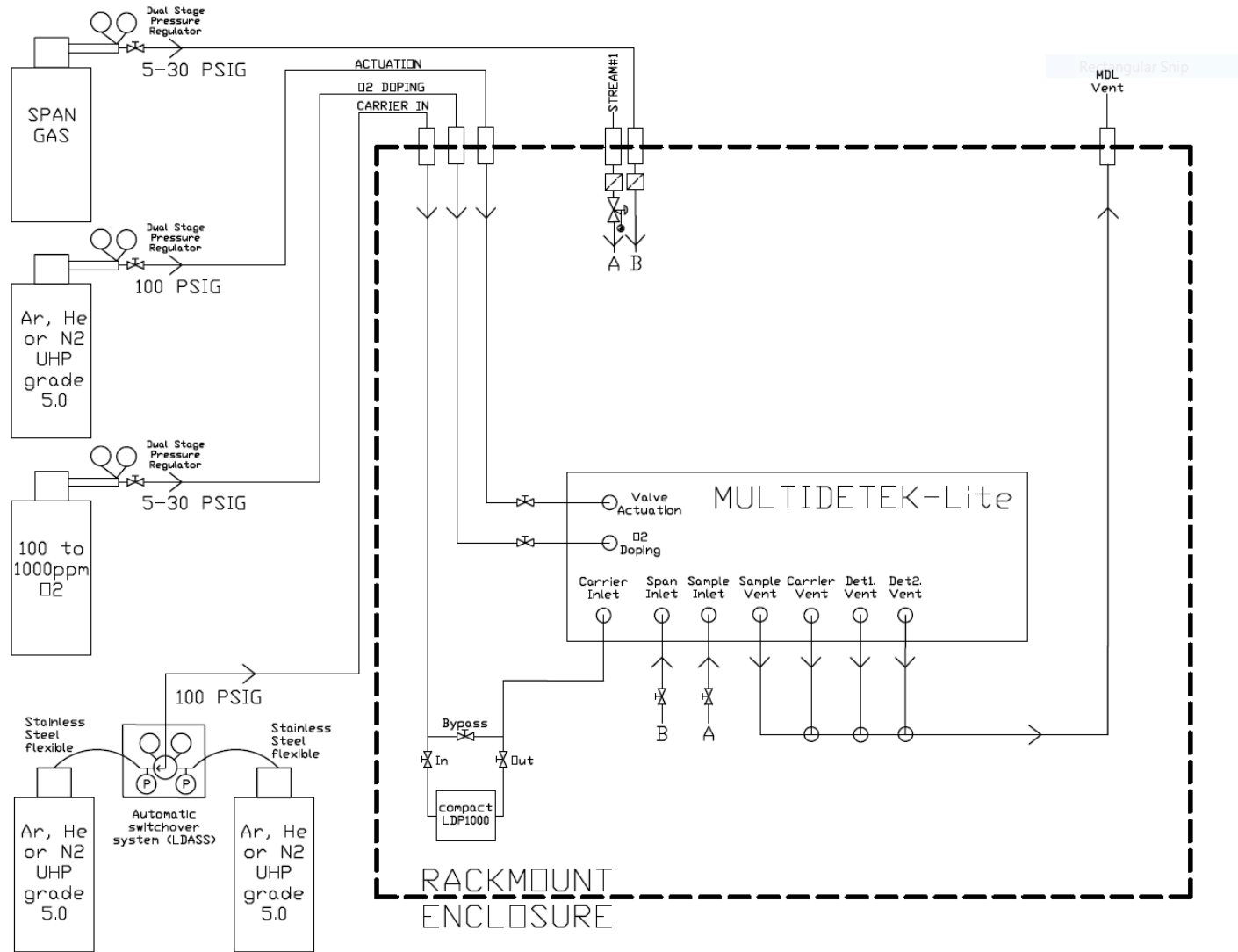

Figure 5: Typical Installation

### 5.5.2. Valves actuation

Separating the actuation from the reference carrier gas allows our gas chromatograph MultiDetek-Lite to achieve better results and more stability. The reason for it is mainly because of pressure changes when valves are actuating during cycles. This causes an impact on the carrier gas pressure and results in baseline fluctuation which can affect the response of the detector. Such events are more visible when low ppb analysis is required. This is due to the high level of sensitivity required for such applications.

Figure 6 and Figure 7 show a typical example of a GC plumbing diagram having a carrier gas supply configured with an automatic switchover system (LDASS). Both figures show a different way to make the gas connections to the actuation. The demonstrated system also includes a stream selector system (LDGSS) allowing different streams to be selected for analysis.

Generally, Argon, Helium or Nitrogen are used as carrier gas. It is important to use an actuation gas having the same specifications as the carrier gas to avoid any hardware damage that could occur if the actuation and carrier gas are mixed unexpectedly. It is worth noticing that the gas consumption for valve actuation will be negligible. A mid-size will consume about 10ml per cycle which is small compared to the few hundred ml/min of carrier consumption.

Figure 6 is the low-cost and easiest way to interconnect the actuation gas to the carrier gas source. This technique avoids the need of installing a second source of gas for actuation. Having a reasonably long volume of piping externally to the GC system acts like a buffer and will absorb the pressure shocks during valve actuation.

Figure 7 is the high-class technique and consists of feeding the GC system with two separate sources. Using this method, the system is completely independent of any variation caused by valve actuation. This is what LDefek recommends for low ppb applications where extreme stability is required to achieve a high level of sensitivity. To implement this method, a second double-stage stainless steel pressure regulator is mounted on a gas cylinder separated from the carrier gas source. As explained above, the actuation gas should be the same type as the carrier.

Using stainless steel pressure regulator/diaphragm/piping/valve/pigtail hoses is required to maintain the leak integrity and purity. A dual-stage control is also needed to avoid pressure fluctuation. Depending on the GC application, other requirements may be necessary. We strongly suggest asking our experts to provide you with the most suitable automatic switchover system for LDefek instruments.

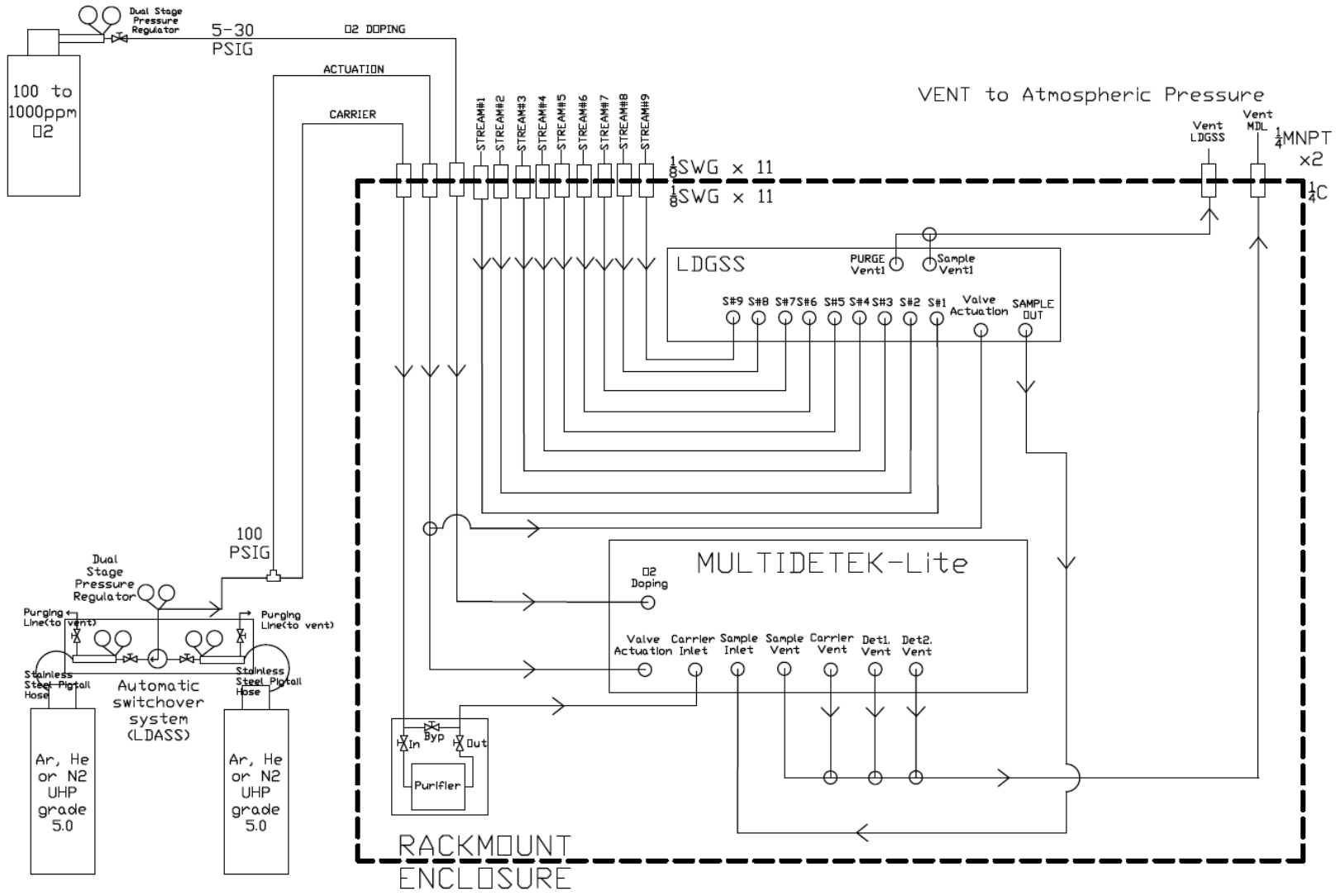

Figure 6: Same source actuation

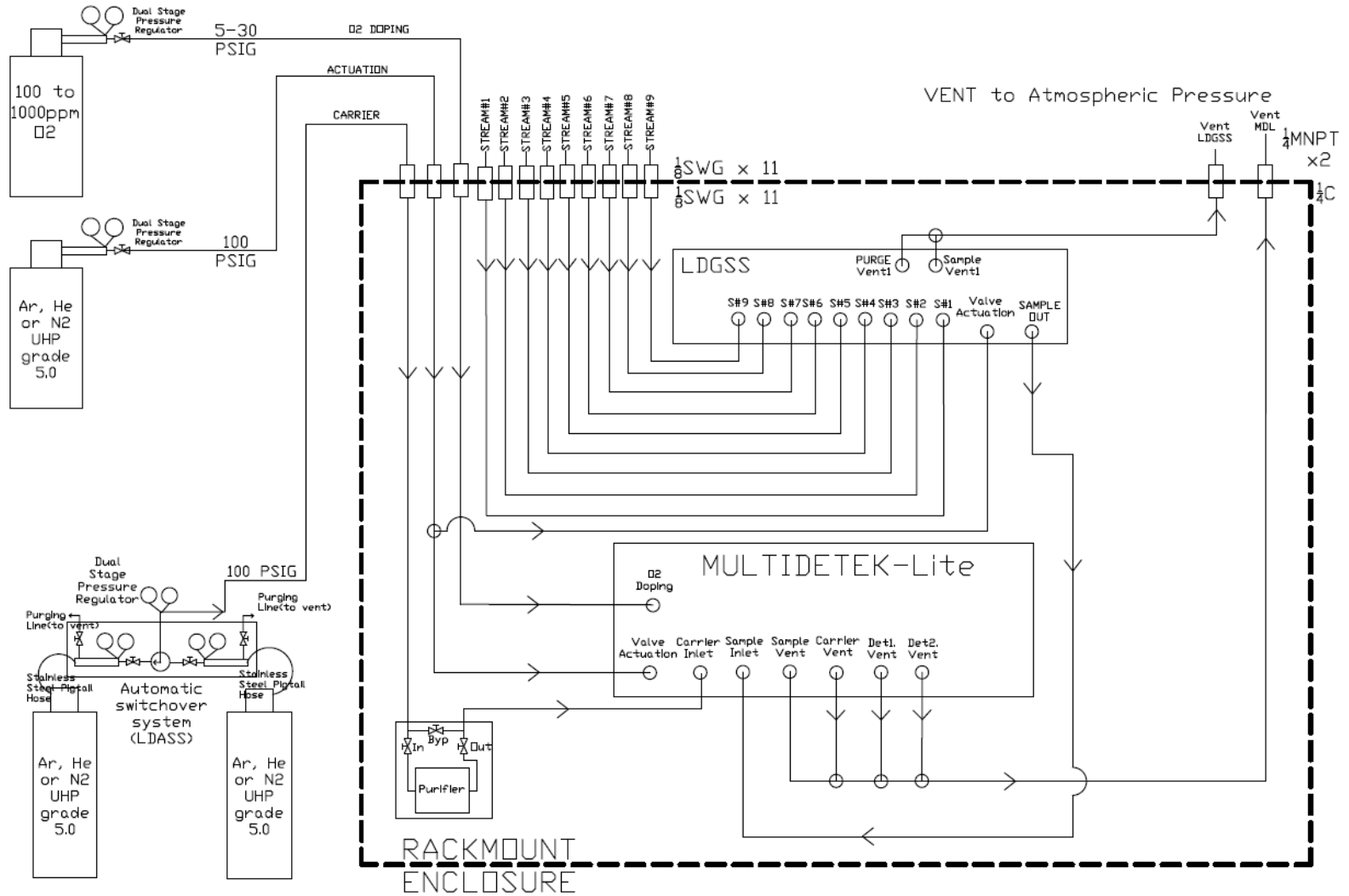

Figure 7: 2 sources of actuation

### 5.5.3. O<sub>2</sub> doping

Figure 5 shows a typical installation that requires O<sub>2</sub> doping. This feature is only required when O<sub>2</sub> is measured at the ppm/ppb level and is used to keep our system saturated with Oxygen. In chromatography, it is well known that oxygen is adsorbed by the Molecular Sieve and the porous polymer-type columns used for separating and measuring trace oxygen. Even if a good column activation is performed at the beginning, over time the oxygen will slowly desorb from the column and the column will start to adsorb the oxygen content coming from the volume of sample gas injected. This phenomenon has a big impact on the analysis accuracy for measuring Oxygen at ppm/ppb due to a part of the sample staying inside the columns. It generally results in a loss of the ppb/ppm peak of Oxygen even on the span calibration gas. By adding an Oxygen doping gas, the active sites inside the columns are permanently filled with Oxygen. It stabilizes the system and ensures good reproducibility and accuracy resulting in better sensitivity.

Figure 8 shows a typical example of a GC plumbing diagram having an O<sub>2</sub> doping option. Valve 4 is a 2 streams selector that switches between the sample gas and the doping gas. The doping inlet must be connected to a certified gas bottle containing a known concentration of O<sub>2</sub> in a balance gas being the same as the carrier gas. In general, the concentration of the doping gas varies between 100-1000ppm O<sub>2</sub>. A rule of thumb is to have the doping concentration 10 times higher than the measuring range. For instance, if the MultiDetek-Lite is configured to measure 0-20ppm O<sub>2</sub>, the O<sub>2</sub> doping bottle should be about 200ppm.

The pressure of this cylinder must be set at a value between 5-30psig. Depending on the GC application, the flow consumption of the doping gas will be as low as 100sccm for a period varying from 2-7 minutes per cycle. When the GC is idle, there is no doping gas consumption. Therefore, such a bottle can last for a long period before needing to be replaced.

Valve 4 is switching to the doping gas at the beginning of an analysis cycle and the doping gas is injected into the channel used to measure the trace oxygen. Generally, the sampling loop of this channel is the first to be injected to ensure that the oxygen doping gas can be injected as quickly as possible, eventually being flushed out of the system rapidly.

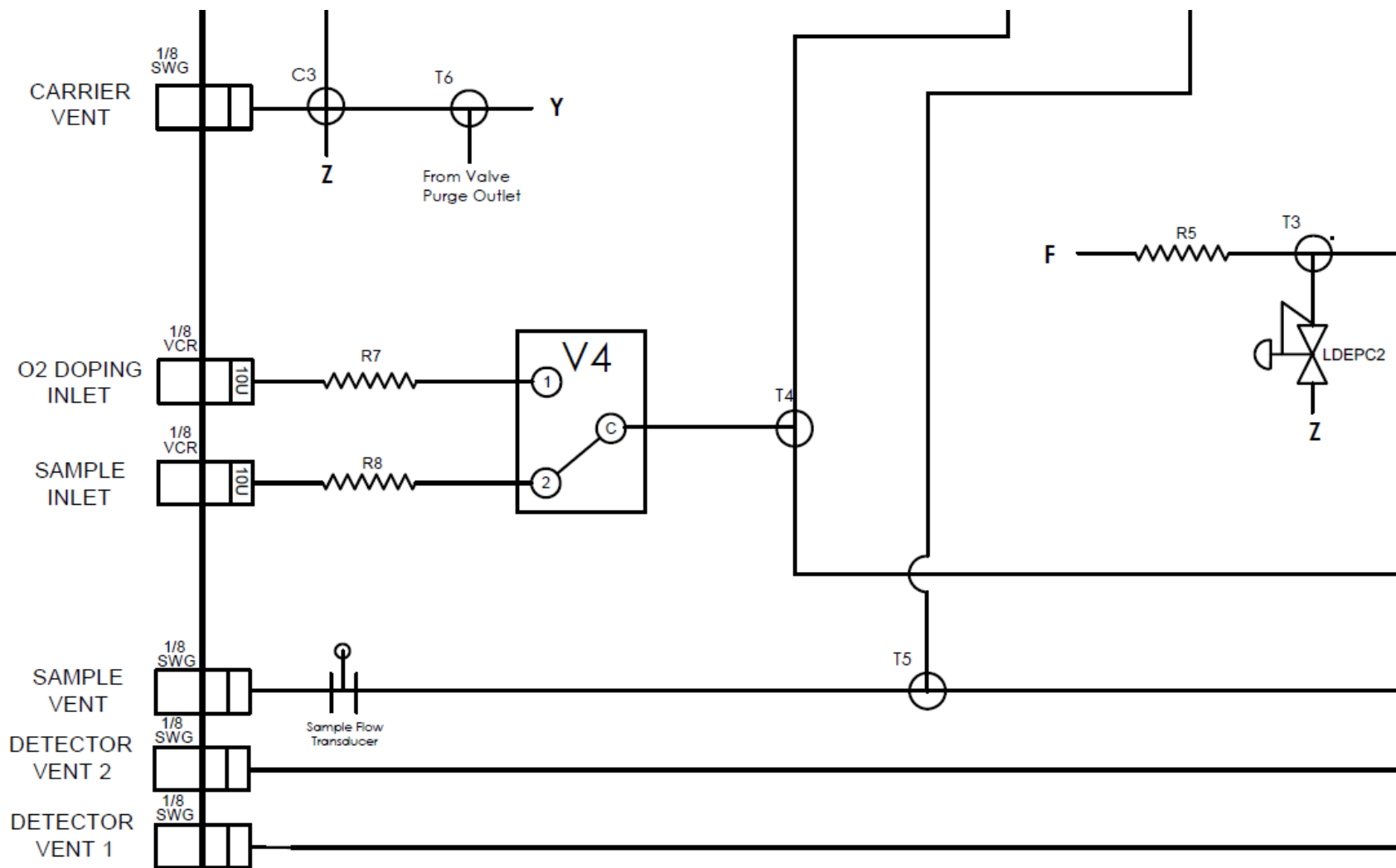

Figure 8: O<sub>2</sub> doping

---

## 6. Hardware description

The MultiDetek-Lite has major components included in its chassis. This section will describe each component that can be replaced for maintenance or upgrade. Please refer to the Ordering section of this manual to get the part number for a replacement part. To order spare parts, please note the serial number of your unit and contact the LDeTek factory at [support@ldetek.com](mailto:support@ldetek.com).

### 6.1. Detectors

The PED detector module is a 155 mm (6.1") x 82 mm (3.22") x 63 mm (2.48") box that contains all components needed to proceed to accurate measurement. The MultiDetek-Lite can accept up to 2 PEDs in the same chassis. This module is maintenance-free. The PED is a very sensitive and selective detector perfect for trace impurities. It can only be defective if the detector has been pressurized or contaminated with liquid or high-concentration hydrocarbons. The PED design is modular and can be easily replaced on-site.

The **FID** detector is used to measure hydrocarbons, and its design makes it suitable for easy operation. The maintenance is easy since it offers easy access. As with any FID, maintenance consists of cleaning the interior of the detector. Its compact design makes it possible to install up to 2 FIDs in the same MultiDetek-Lite chassis or in a combination with other detectors.

The **TCD** is used to measure impurities at a high concentration and is used to be a complement to the PED detector. It can be installed in series or parallel with the PED and then offers a very wide dynamic measurement range. The TCD is also modular and is easy to manipulate for maintenance.

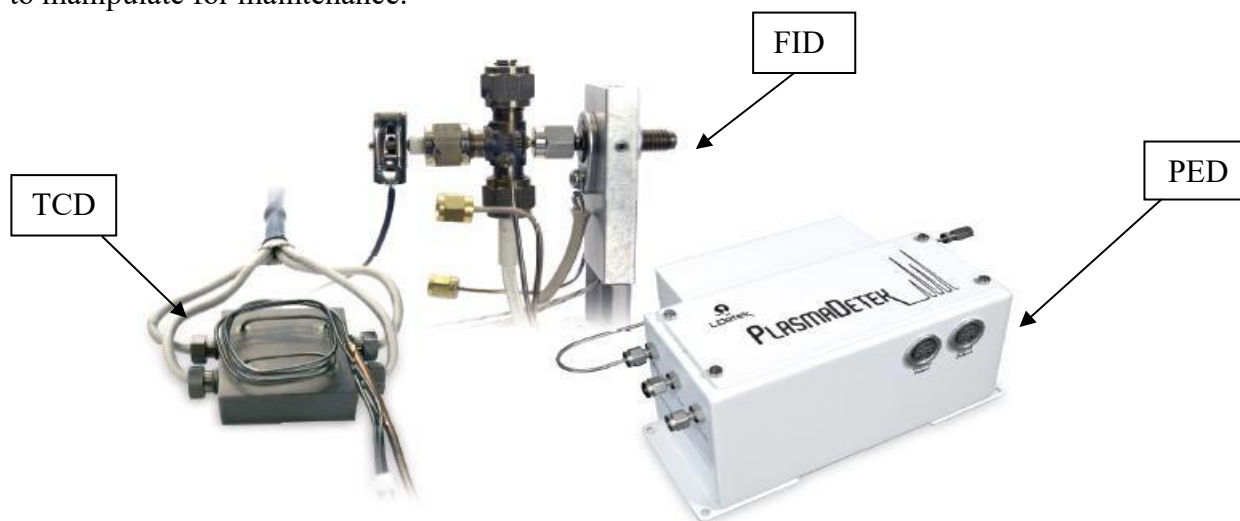

Figure 9: Type of Detectors

## 6.2. Online Sensors

The **SenzTx** is an oxygen transmitter available with either zirconia or electrochemical sensing technology. It provides continuous measurement of oxygen concentration across a wide range, from 0.5 ppm to 96 % O<sub>2</sub>, depending on the selected configuration. The sensor is designed for stable, long-term operation in process environments.

The **Easidew** sensor measures moisture in terms of both dew point and moisture content. It operates over a range from -110 °C to +20 °C dew point (-166 °F to +68 °F) and uses a ceramic sensing element with integrated microprocessor-based electronics to ensure accurate and repeatable readings throughout the service life of the transmitter.

The **QMA** sensor determines trace moisture concentration by monitoring the frequency modulation of a hygroscopic-coated quartz crystal. This method provides high sensitivity to water vapor, with a detection limit down to 20 ppb H<sub>2</sub>O, making it suitable for trace-level moisture applications.



▲ SenzTx



▲ Easidew



▲ QMA

---

### 6.3. **Motherboard**

This motherboard controls all components inside the analyzer (e.g. flows, signals, LCD display, temperature, 4-20mA, etc.). It is comprised of the master board (MCU) as well as different sub modules. The master board communicates with these sub-modules through the bus board. Here is a list of the boards with a short description:

- ACDC Board: Used to convert main voltage to 24V DC
- Bus Board: Backbone of the board assembly.
- Master Board: Brain of the board assembly.
- Plasma board: Used to control the detector and HCD
- Flow board: Used to control the flows, 4-20mA outputs and relays
- Multi board: Used to control detectors, HCDs, flows, 4-20mA outputs and relays
- 4-20mA board: Used to control 4-20mA outputs and relays
- Oven board: Used to control the ovens
- TCD board: Used to control the TCD module
- FID board: Used to control the FID modules

These boards must only be replaced with LDetek's confirmation, as there is a risk of electrical shock. These boards are not plug-and-play replaceable. If a board needs to be replaced, contact LDetek for the proper procedure.

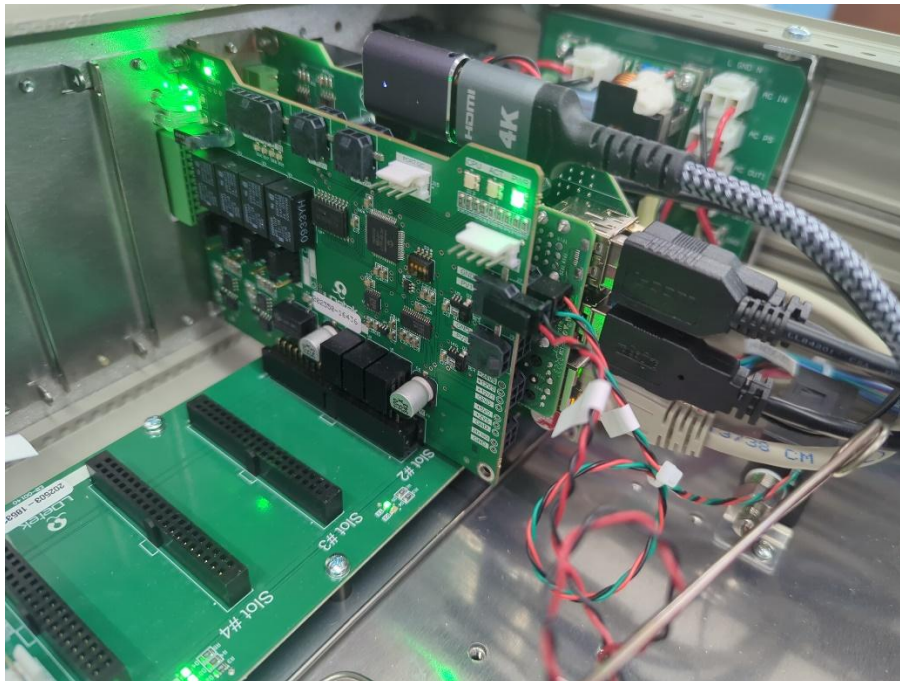

Figure 10: MultiDetek-Lite printed circuit board (PCB)

### 6.3.1. ACDC Board

The ACDC board converts the main supply voltage to 24V DC and supplies it to the bus board.



Figure 11: ACDC Board

### 6.3.2. Bus Board

The PCBs in the MultiDetek-Lite are arranged in a modular way. The bus board is the backbone of the electrical system. It distributes DC power to each board. In fact, all other boards are connected to it through a slot connector or via a wire harness plugged into the slave connector. RS-422 communication also travels through the slot connectors and the wire harness.

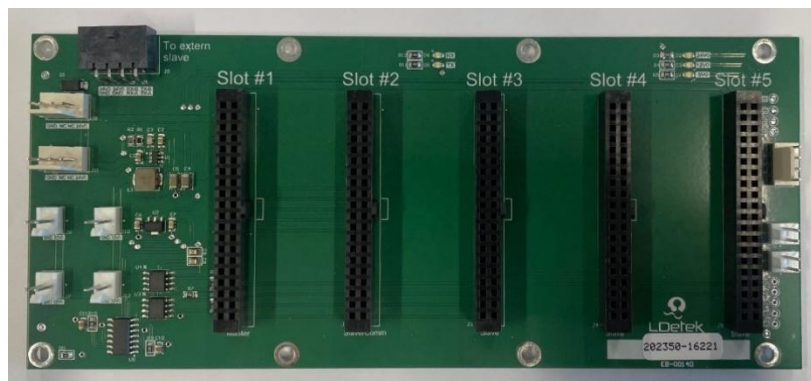

Figure 12: Bus Board

---

### 6.3.3. Master Board

The master board is the brain of the MultiDetek-Lite. It hosts the operating system and a server for remote access through a web browser. The master board ensures communication with the outside world and sends data to the display. It is also responsible for sending commands and queries to the slave boards in the MultiDetek-Lite (plasma board, flow board, multi board, 4-20mA board, oven board, TCD board, FID board, etc.).



Figure 13: Master Board

### 6.3.4. Plasma Board

The plasma board is responsible for operating the PEDs and the HCDs. It powers the detectors and reads the output signals. Additionally, the plasma board is responsible for maintaining the HCDs at a constant temperature. It reads the temperature using an RTD and supplies voltage to the heating element as needed. The plasma board responds to commands and queries from the master board; it does not operate on its own.

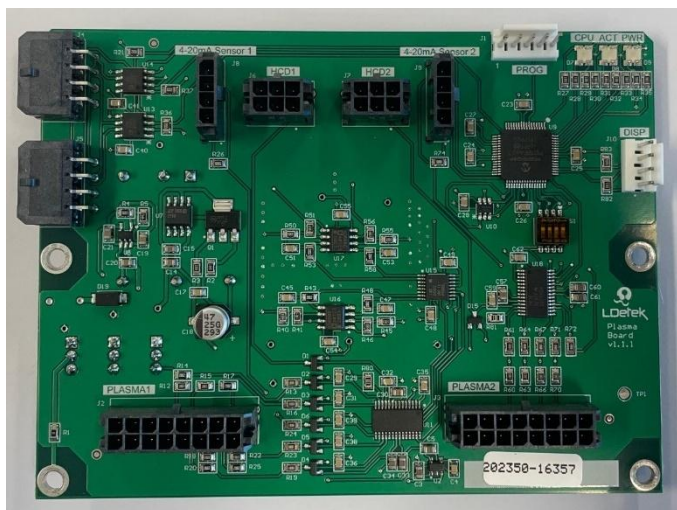

Figure 14: Plasma Board

### 6.3.5. Flow Board

The flow board is responsible for reading and regulating flow rates and pressures. To perform these operations, it reads flow rate sensors and pressure sensors, and it controls proportional valves. The flow board also controls the on/off valves used to actuate the diaphragm valves. Additionally, it controls 2 non-isolated 4-20mA outputs and 4 output relays. The flow board responds to commands and queries from the master board; it does not operate on its own.

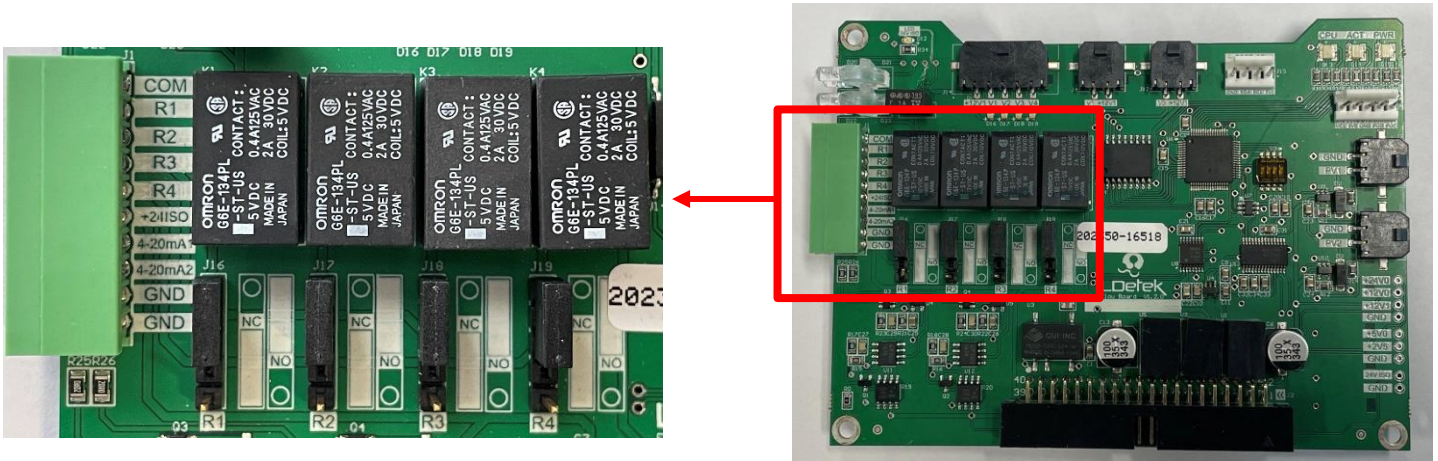

Figure 15: Flow Board

The flow board provides 4 relays that can be configured as N.O. or N.C. using the jumpers. The voltage must be limited to **24 V**, and the current must be limited to **100 mA**. The flow board also provides 2 non-isolated 4-20mA outputs. The maximum load is **500Ω**. A 24 V output is also provided, the maximum output current is 50mA.

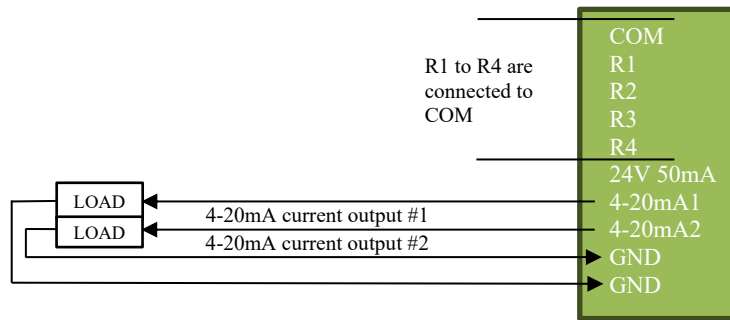

Figure 16: Flow Board Output Connector

### 6.3.6. Multi Board

The multi board is a hybrid between a plasma board and a flow board. It can operate a PED and an HCD. It powers the detector and reads the output signals. Additionally, the multi board is responsible for maintaining the HCDs at a constant temperature. It reads the temperature using an RTD and supplies voltage to the heating element as needed. It can read and regulate flow rates and pressures. To perform these operations, it reads flow rate sensors and pressure sensors, and it controls proportional valves. The multi board also controls the on/off valves used to actuate the diaphragm valves. Finally, it controls an isolated 4-20mA output and 8 output relays. The multi board responds to commands and queries from the master board; it does not operate on its own.

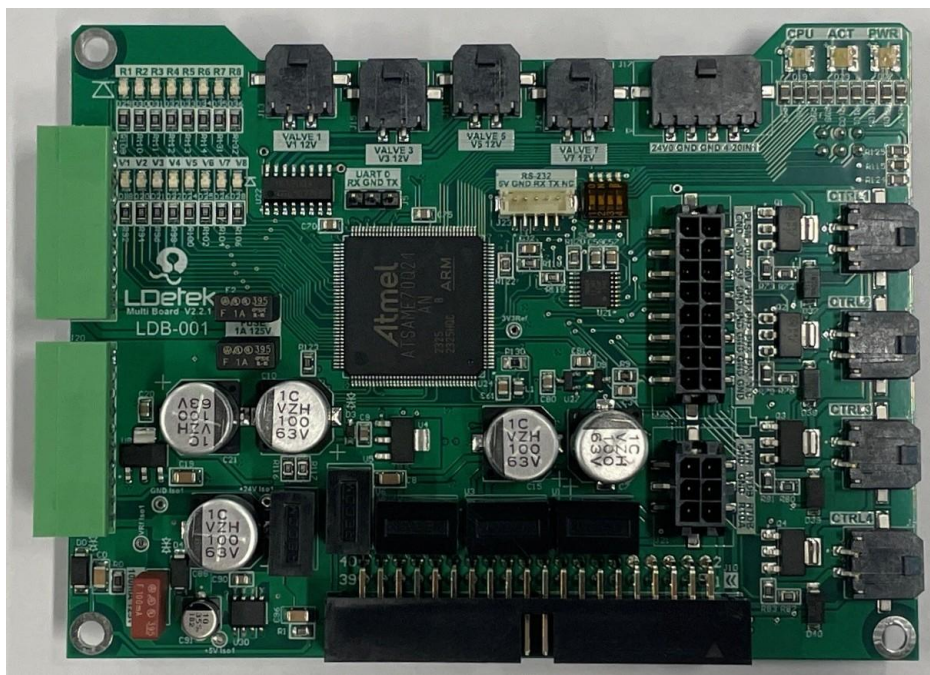

Figure 17: Multi Board

The Multi Board provides 8 solid-state relays. The voltage must be limited to **24 V**, and the current must be limited to **100 mA**. Relays R1 and R2 are normally closed, while R3 to R8 are normally open.

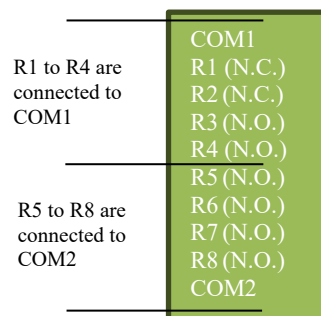

Figure 18: Multi Board Relay Connector

The Multi Board provides an isolated 4-20 mA output. The maximum load is **500 Ω**. A 24 V output is also provided and shares the same reference as the 4-20 mA output. The maximum output current is **50 mA**.

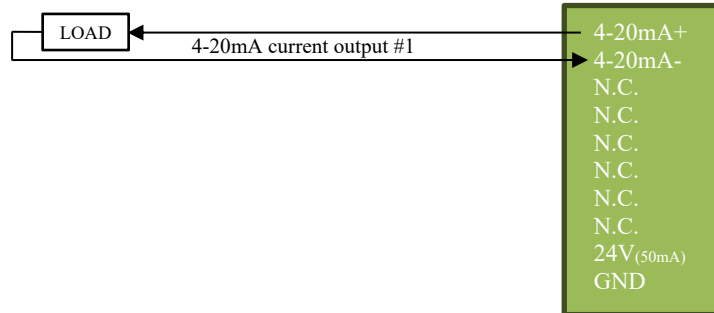

Figure 19: Multi Board 4-20mA output

### 6.3.7. 4-20mA Board

The 4-20mA board provides 5 isolated 4-20mA outputs and 4 output relays with N.O. and N.C. contacts. The 4-20mA board responds to commands and queries from the master board; it does not operate on its own.



Figure 20: 4-20mA Board

The 4-20mA board provides 5 isolated 4–20 mA outputs. The maximum load is **500 Ω**.

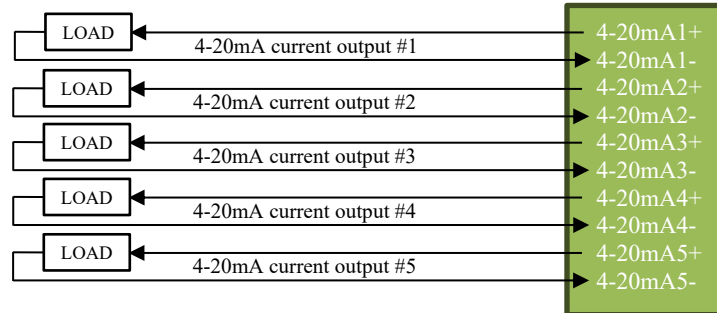

Figure 21: 4-20mA Board Outputs

The 4-20mA board provides 4 mechanical relays. The voltage must be limited to **24 V**, and the current must be limited to **100 mA**.

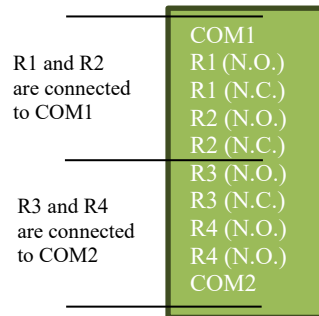

Figure 22: 4-20mA Board Relay Outputs

### 6.3.8. Oven Board

The oven board is responsible for reading and regulating the temperature of the ovens. It reads temperatures using an RTD or a thermocouple and supplies voltage to the heating elements of each oven as needed. The oven board responds to commands and queries from the master board; it does not operate on its own.



Figure 23: Oven Board

### 6.3.9. TCD Board

The TCD board is responsible for operating the TCD module. It supplies current to the sensing element and reads the output signal. Additionally, the TCD board is responsible for maintaining the TCD module at a constant temperature. It reads the temperature using an RTD and supplies voltage to the heating element as needed. The TCD board responds to commands and queries from the master board; it doesn't operate on its own.

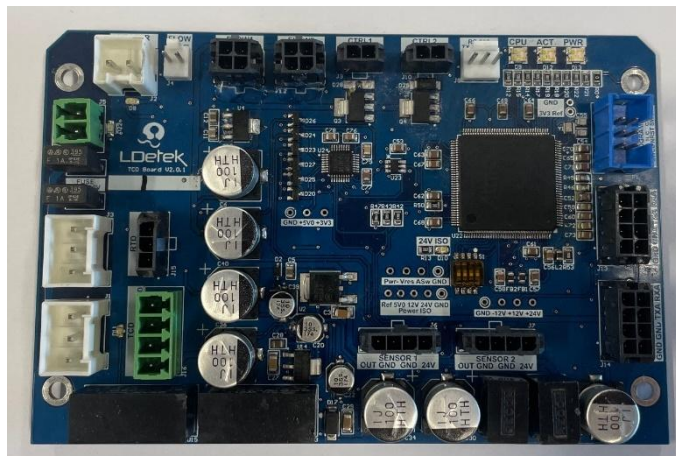

Figure 24: TCD Board



## 6.4. Sample gas proportional valve

This valve is used to control the sample flow inside the instrument. This is a very low dead volume valve that allows minimal purging time at start-up and is very quick for flow stabilization. This valve has been designed by LDetek to achieve good stability and the possibility of working at ppb level without contamination

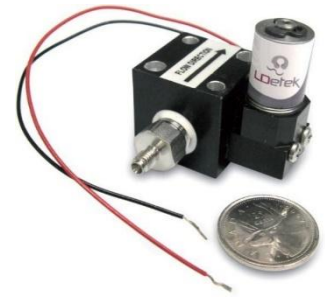

Figure 26: Solenoid proportional valve

## 6.5. Display with Touch Screen (7" 800x480)

This 7" display provides a user-friendly interface. Moreover, its touch screen allows easy navigation through the different menus. Carefully handling the touch screen is essential to avoid damaging it.



If the display is damaged, it can be easily replaced by removing the back plate of the door and the four fixing screws. A new display can be ordered from LDetek.

## 6.6. Serial port

As shown on section 8.3, the MultiDetek-Lite comes with a RS-232/RS485 port that can be used for communications. Note that Modbus is only available as an option.

## 6.7. Relays

The MultiDetek-Lite comes standard with 4 relays that can handle a maximum of 24 V. Both N.O. (normally open) and N.C. (normally closed) contacts are available. By default, a system status relay is set up.

Relay functions are customizable in the settings. The function of each relay can be modified to activate based on ranges, alarms, or calibration. Connection details and additional information can be found in section 6.3 and 8.3. Feel free to contact us at [support@ldetek.com](mailto:support@ldetek.com) for more details.

## 6.8. 4-20mA module

As an option, the MultiDetek-Lite comes with 4-20mA outputs. Connection details and additional information can be found in section 6.3 and 8.3.

---

## 6.9. Diaphragm valve

The MultiDetek-Lite can have up to 2 units of 6 or 10 ports diaphragm valves. This type of valve is robust, configured for high purity and small size for compact environments. The proper valves are used depending on the application. The valve maintenance is every 3-5 years depending on application.



## 6.10. Carrier gas electronic pressure regulator (LDepec)

The carrier gas flow control in the MultiDetek-Lite is managed by a high-purity LDefetek electronic pressure controller (EPC). The carrier flow control can be mounted inline or in bypass mode depending on the application.

A manual version of the high-purity pressure regulator is also available in the MultiDetek-Lite. Both versions are available and can be easily replaced because of their modular designs.



## **6.11. Ovens and columns**

The MultiDetek-Lite can have up to 3 isothermal. These ovens can be accessed from the front door which facilitates column replacement. Each oven can fit up to 2 x packed, micro-packed or PLOT-type columns. The columns can be 1/8" OD, 1/16" or PLOT type and the maximum operating temperature of each oven is 200 °C. A safety temperature cut-off switch protection is installed in each oven to avoid overheating.



*Figure 27: Isothermal and programmable oven*

## 7. Operation

### 7.1. User interface

This section provides an overview of the user interface. Feel free to contact LDeTek at [support@ldetek.com](mailto:support@ldetek.com), if you need clarifications.

#### 7.1.1. Analysis menu

The Analysis Menu displays real-time information about the analyzer, allowing users to monitor its performance and status.

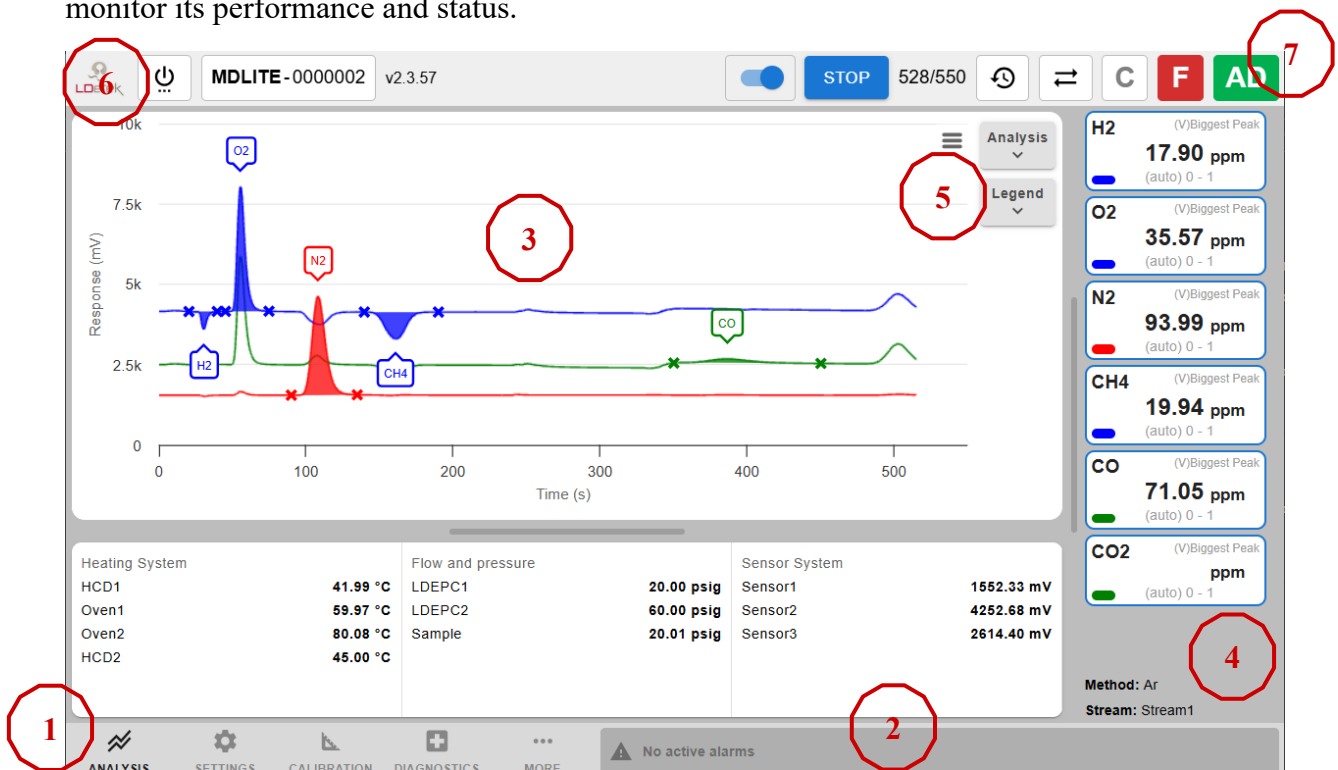









Figure 28: Analysis menu

- 1. Left Bottom Bar:** This bar allows you to switch between different menus. The buttons enable you to navigate to the Analysis, Settings, Calibration, Diagnostics, and More menus respectively.
- 2. Right Bottom Bar:** This bar provides vital information about alerts on the MultiDetek-Lite. The color of the bar changes to red when one or more alarms are active and yellow when there is a warning. If the bar is gray, it indicates that there are no alarms, and the system is ready for analysis. Double-clicking on the bar will open the Alarms Menu, where users can view detailed information about the alerts, including their type and the date they occurred.
- 3. Graphic:** This section shows the chromatogram with the X-axis indicating time in seconds and the Y-axis representing the sensors signal in millivolts. You can zoom in

---

by clicking and dragging a box, and un-zoom by right-clicking.

4. **Side bar:** The top section displays the real-time concentration of the components. The bottom part of the side bar shows information about the method and stream being used.
5. **Analysis & Legend:** The legend allows you to hide and display peaks or sensors on the chromatogram. The analysis allows you to switch between the analysis view which shows the chromatogram or the trending view which can be configured to show different parameters for diagnostics.
6. **Top-Left Corner:** This area shows the instrument serial number and software version. By clicking on the serial number, you can enter the About Menu. The shutdown button is also positioned there.
7. **Top-Right Section:** This section displays icons that indicate the status of the analyzer.
  - a. The slider  allows you to enable or disable automatic restart.
  - b. The Start/Stop button  allows you to start or stop an analysis.
  - c. The countdown displays information about the cycle time. The numerator indicates the current time in the analysis, while the denominator shows the total cycle time.
  - d. The historic icon  allows you to open the historic menu.
  - e. When colored, the connection icon  indicates that the communication between the software and firmware is established.
  - f. The calibration icon  indicate that a calibration is being performed using presets. By clicking on this icon, it is possible to stop a calibration.
  - g. The force icon indicates that a force as been aply to the analyzer. By clicking on this button, it is possible to reset these forces: .
  - h. The last icons indicates the login information. When grey, it means that the analyzer is in user mode . When showing "AD", it means that the analyzer is in admin mode. By clicking on this button, it is possible to switch between user and admin mode.

### 7.1.2. Settings menu

The settings menu is where all the system parameters can be accessed. However, it is important to note that making changes to these settings without proper knowledge and guidance can negatively impact system performance. Therefore, any changes made to the settings in this category should only be done after consulting with LDetek support. Furthermore, the available settings may vary depending on the software version installed. To update the software, please contact LDetek support to ensure compatibility with your system.

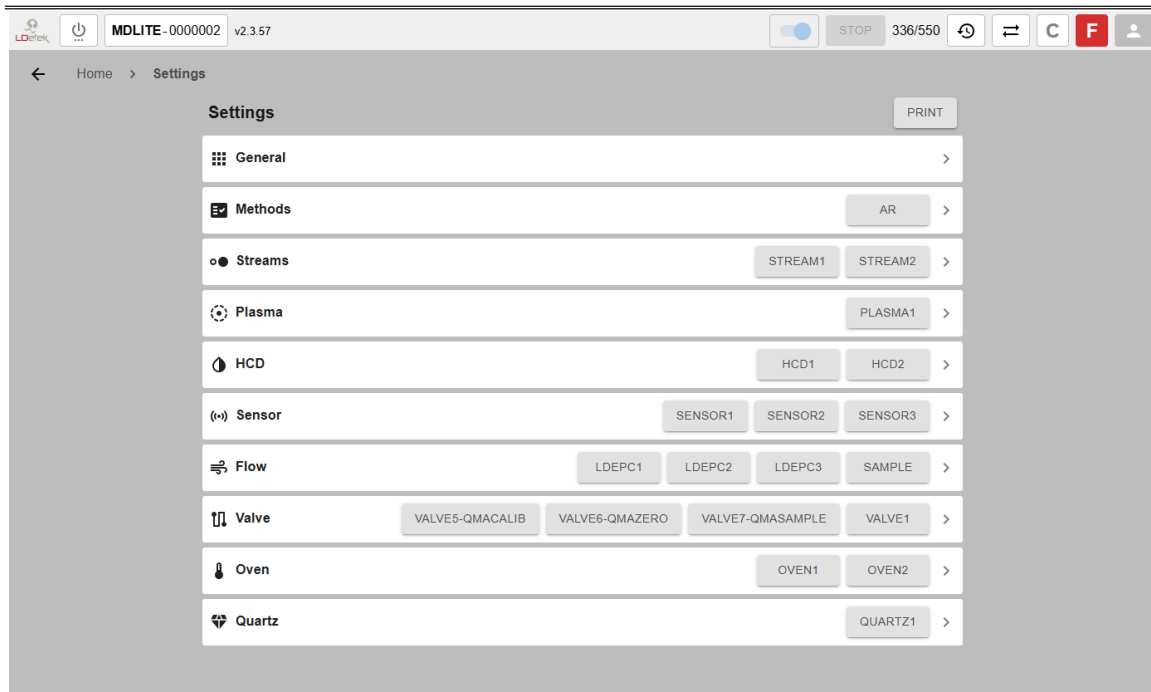

Figure 29: Settings menu

**General:** This section displays general settings like graphic duration.

**Method:** This section displays settings related to the methods configured within the analyzer.

**Streams:** This section displays settings for analyzers with an integrated stream selector.

**Plasma:** This section displays settings related to the plasma emission detector.

**HCD:** This section displays settings related to the HCDs.

**Sensor:** This section displays settings related to the sensors installed in the detector.

**Flow:** This section displays settings related to the flows.

**Valve:** This section displays settings related to the valves.

**Oven:** This section displays settings related to the ovens.

**Quartz:** This section displays settings related to the QMA.

### 7.1.3. Calibration menu

The calibration menu is where the calibration can be done.

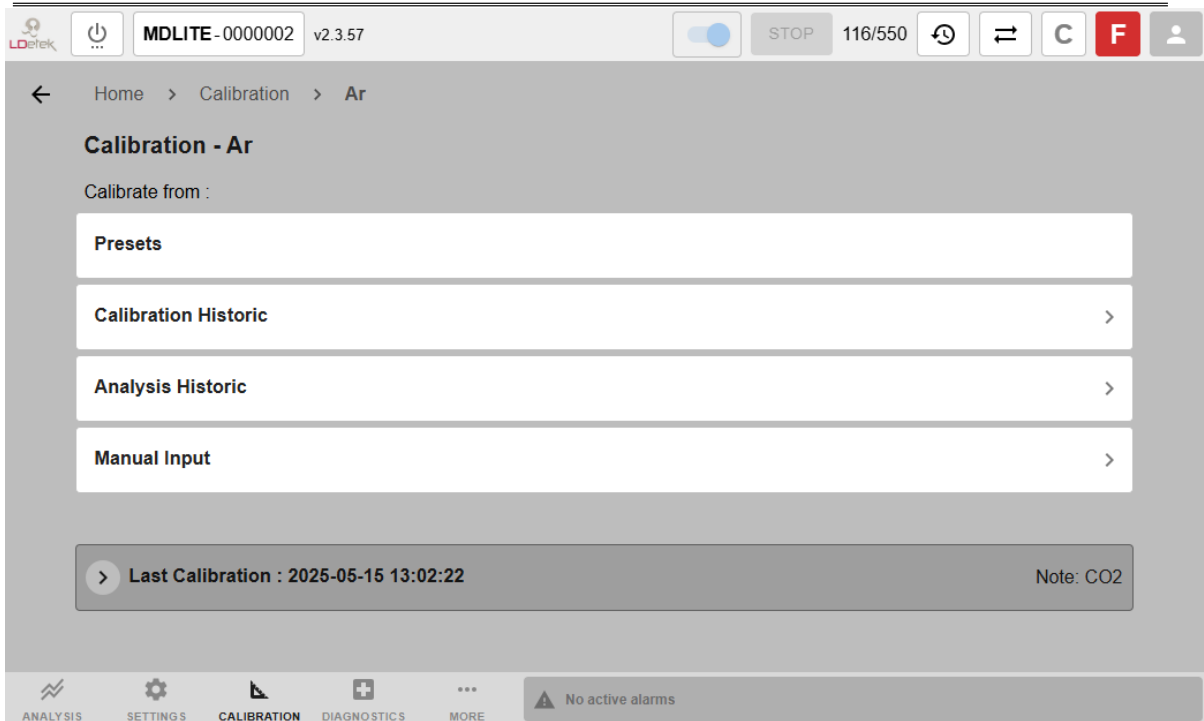

Figure 30: Calibration menu

**Preset:** This section allows you to configure presets for automatic calibration. This is explained in detail in section 7.2.5.

**Calibration Historic:** This section will show you details about previous calibrations done on the analyzer.

**Analysis Historic:** This section allows you to calibrate using an analysis from the historic.

**Manual Input:** This section allows you to do a manual calibration.

**Last Calibration:** This section displays details about the last calibration.

#### 7.1.4. Diagnostic menu

This section displays the real-time values of the most critical components in the instrument. It allows you to validate whether the instrument components such as the relays, flows or the heaters modules are operating optimally. By monitoring these values, you can quickly identify any irregularities or potential issues that may affect the performance of the instrument.

In addition to monitoring, the Diagnostics Menu provides the capability to force or unforce any components such as relays, flows, etc. This means you can manually activate or deactivate specific components to test their functionality or to troubleshoot issues. For example, if you suspect a component is not working correctly, you can force it to operate

and observe its behavior in real-time.

Overall, the Diagnostics Menu is an essential tool for maintaining the reliability and efficiency of the instrument, providing both real-time monitoring and control capabilities.

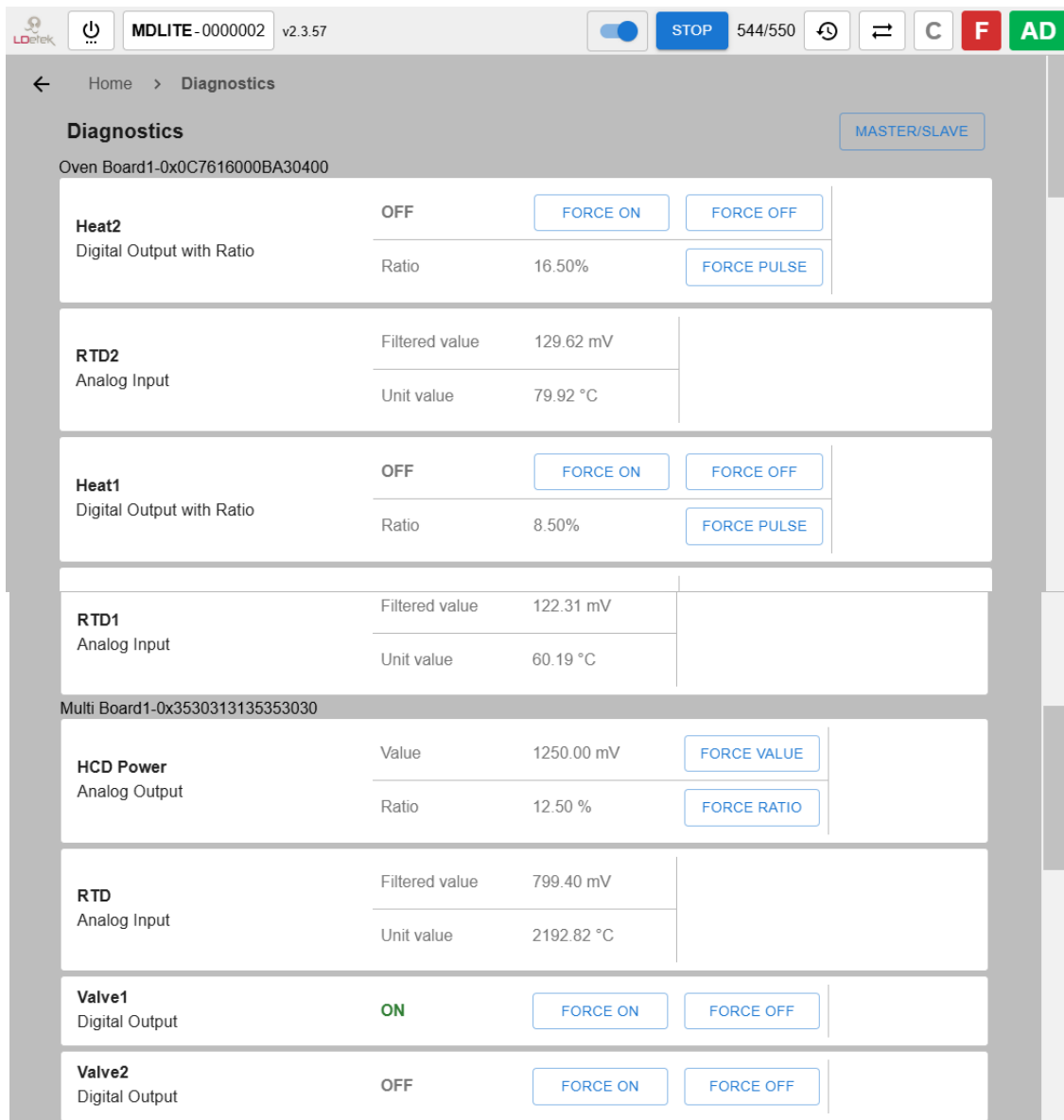

Figure 31: Diagnostic menu

## 7.1.5. More menu

In this section, you will have access to additional information and settings for various parameters of the device. The More Menu provides several important functionalities that enhance the usability and customization of the instrument.

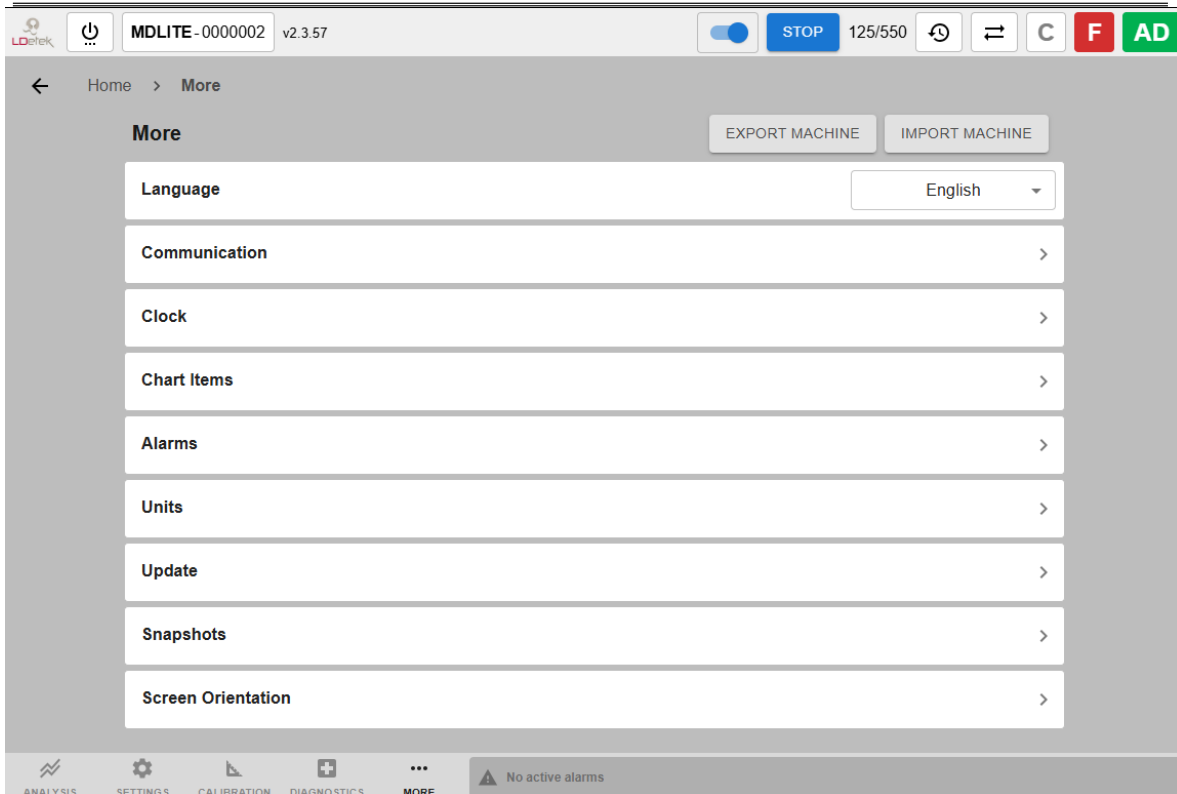

Figure 32: More menu

**Export/Import Machine:** This section allows users to import and export a machine file. This can be used to backup the data on an external drive.

**Language:** This section allows users to change the language of the interface.

**Communication:** This section allows you to configure Modbus communication settings.

**Clock:** This section allows you to set and adjust the device's clock.

**Chart Items:** This section allows you to hide/show items such as flows and temperatures on the graphic.

**Alarms:** This section opens the Alarms menu and can also be accessed by double-clicking on the right-bottom bar.

**Unit:** This section allows you to change the unit (e.g. flow, temperature, pressure, etc.).

**Update:** This section allows you to update the software.

**Snapshot:** This section allows you to take a snapshot to save the current setting and load an old snapshot if needed.

**Screen Orientation:** This section allows you to change the screen orientation.

## 7.2. Software procedures

This section will show a few procedures that can be helpful while using the MultiDetek-Lite. Feel free to contact us at [support@ldetek.com](mailto:support@ldetek.com) if you have any questions.

### 7.2.1. How to switch from the user to the admin mode

1. If you are in user mode, the login button on the top-right corner will be grey. Click on this button to switch to the admin mode.



2. The login menu will open then enter the username and password and click on login. By default, the username is “admin”, and the password is “12345”.

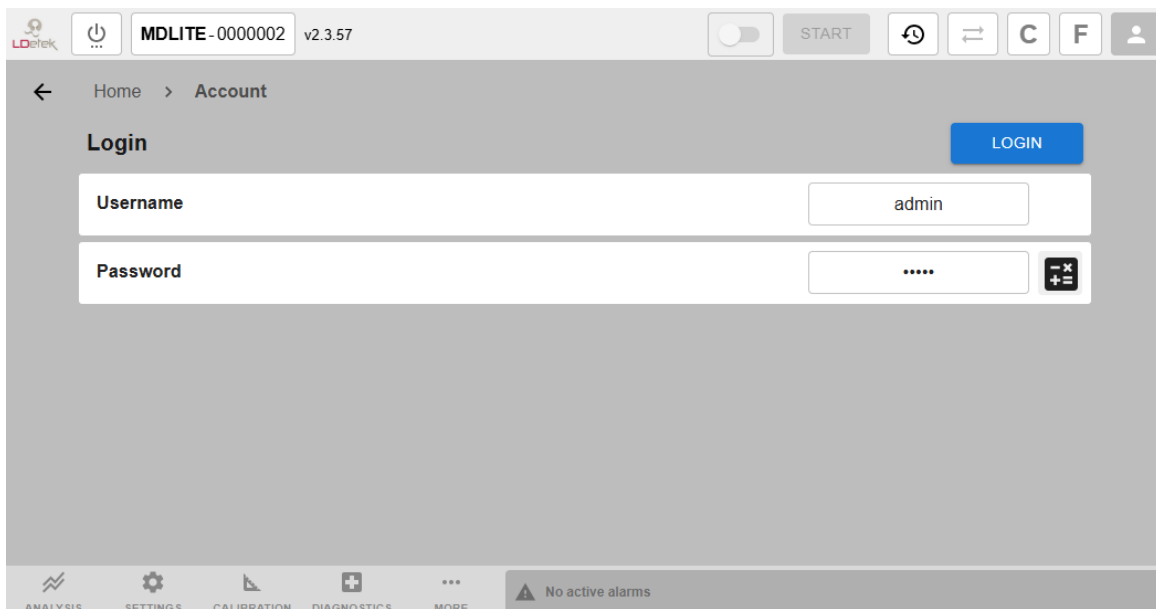

3. You can confirm that you have entered the admin mode by looking at the top-right corner. The login button will display “AD”.



---

### 7.2.2. How to switch from the admin to the user mode

1. If you are in admin mode, the login button on the top-right corner will be green and showing “AD”. Click on this button to switch to the user mode.
2. The account menu will open then click on Logout.

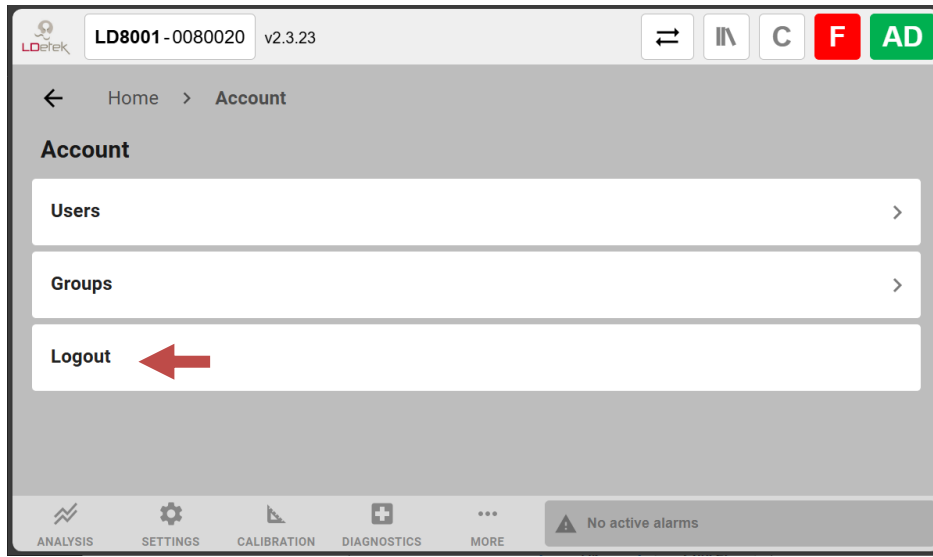

4. You can confirm that you have entered the user mode by looking at the top-right corner. The login button will be grey.



### 7.2.3. How to switch between methods

1. If the analyzer is configured with more than one method, they can be changed from the main menu. To do so, click on “method” located on the bottom-right corner above the alarm button.
2. A slider will open, then click on “Method”.

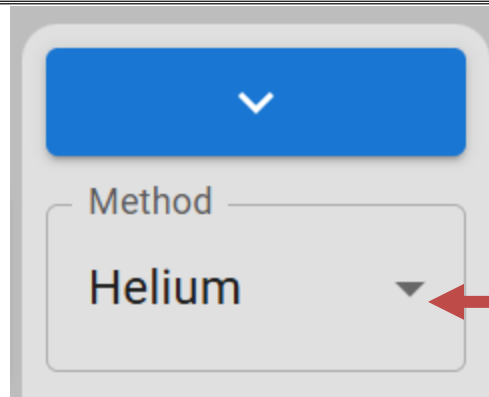

3. A drop-down menu will open allowing you to select the method you want. The selected method will be shown on the bottom-right corner of the main menu.

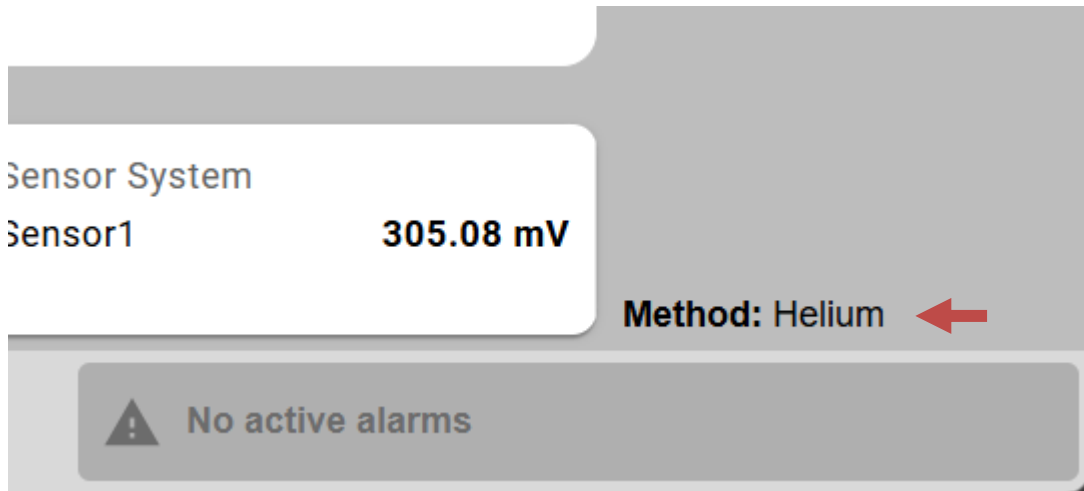

#### 7.2.4. How to switch between streams

1. If the analyzer is configured with an integrated stream selector or if it is connected to an LDGSS, streams can be changed from the main menu. To do so, click on “stream” located on the bottom-right corner above the alarm button.
2. A slider will open, then click on “Stream”.

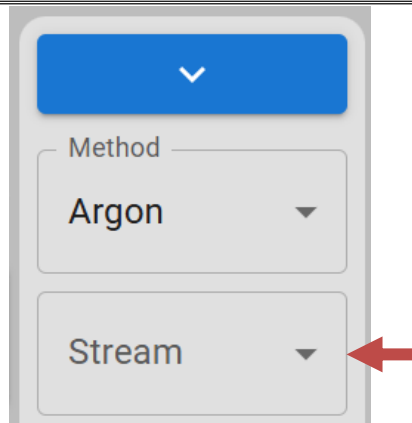

3. A drop-down menu will open allowing you to select the stream you want. The selected stream will be shown on the bottom-right corner of the main menu.

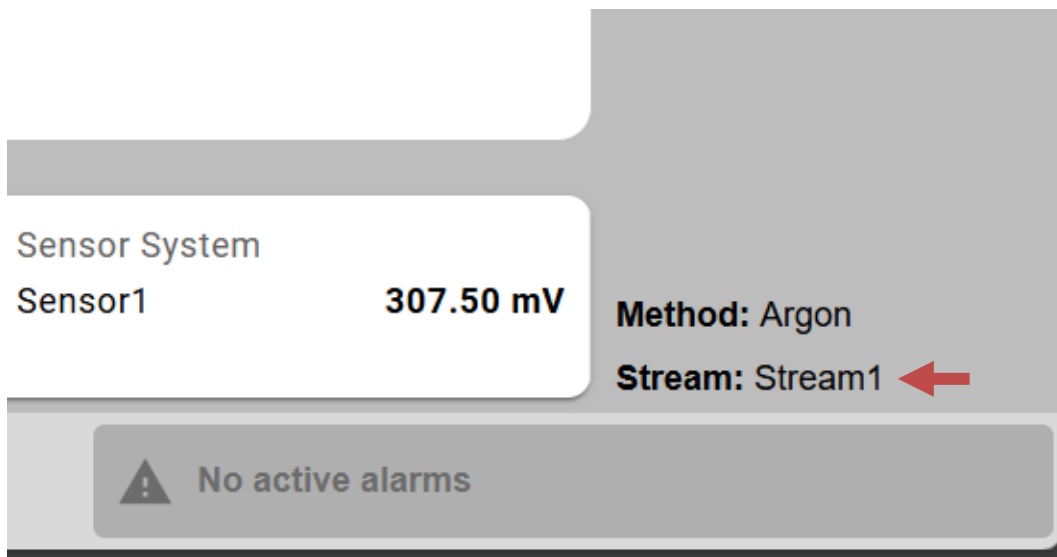

## 7.2.5. How to calibrate the MultiDetek-Lite

### 7.2.5.1. How to manually calibrate the MultiDetek-Lite

LDetek recommends running at least 3 analysis cycles before performing a calibration to ensure stable and repeatable measurements.

1. Access calibration menu:

Follow the procedure in section 7.2.1 to switch to the admin mode.

From the bottom navigation bar, click on Calibration.

Then select the method to calibrate (example: O2).

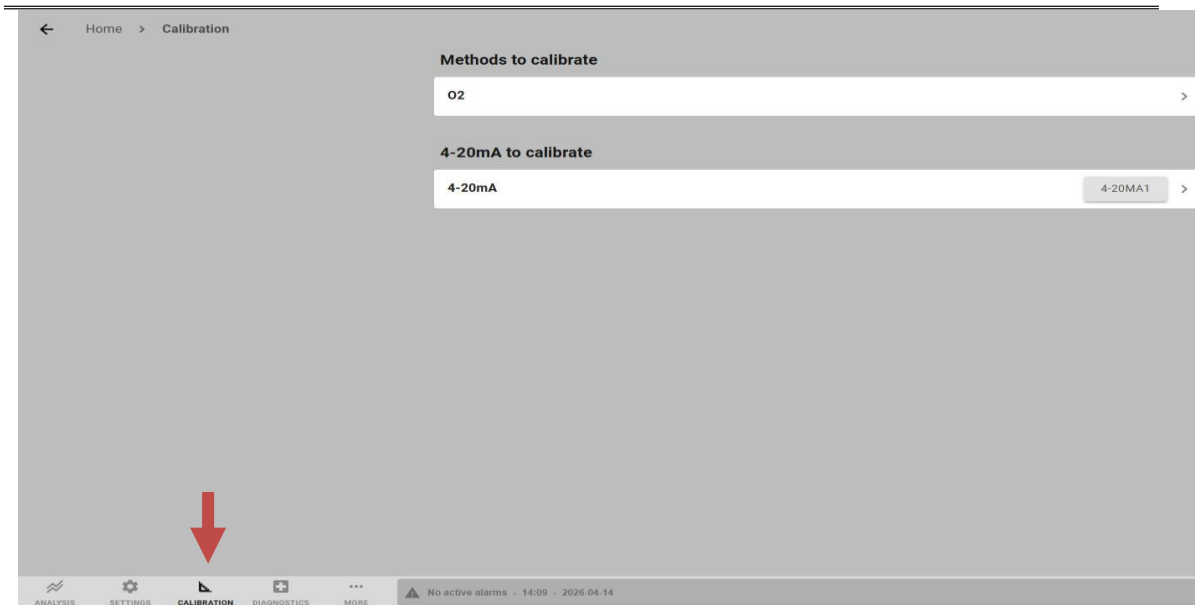

## 2. Select calibration method:

In the calibration menu, multiple options are available:

- Presets
- Calibration Historic
- Analysis Historic
- Manual Input
- Calibration Certificate

All calibration methods listed above are functional and can be used depending on the application and user preference. For example, Presets can be configured to simplify calibration, while Analysis Historic or Calibration Historic can be used based on previous data.

The Manual Input method is used here as an example and is described below.

Click on Manual Input to perform the calibration.

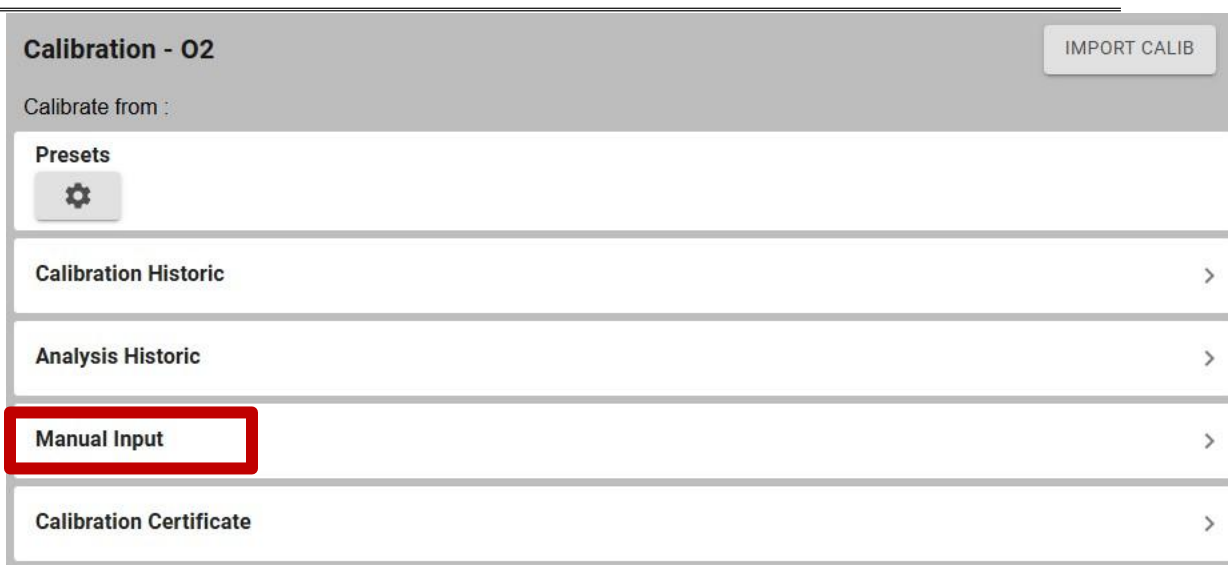

3. Manual calibration interface:

The following fields are available in this window:

- Zero calibration
- Span calibration
- Calibration table

Span calibration is used for a single-point calibration, while the Calibration table is used for multi-point calibration. For detailed calibration, the Calibration table method is used as an example in the following section.

Go to the Calibration table section to enter the corresponding area and ppm (or ppb) values after running at least 3 analysis cycles.

a. How to retrieve the detector response (area) from Analysis History:

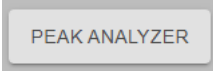
- From the Analysis menu, click on the History icon (top right)  to access the Analysis History interface.
- Select the desired analysis cycle from the list to view its details.
- The analysis graph and results will be displayed.
- Click on “Peak Analyzer”  to access detailed peak information.
- In the results table, locate the “Area” column. The values shown for each peak correspond to the detector response (area) and can be used for calibration

b. Enter calibration values:

In the calibration table, enter the detector response (area) and the corresponding concentration (ppm or ppb). Each row represents a calibration point.

The figure below shows several calibration points as examples.

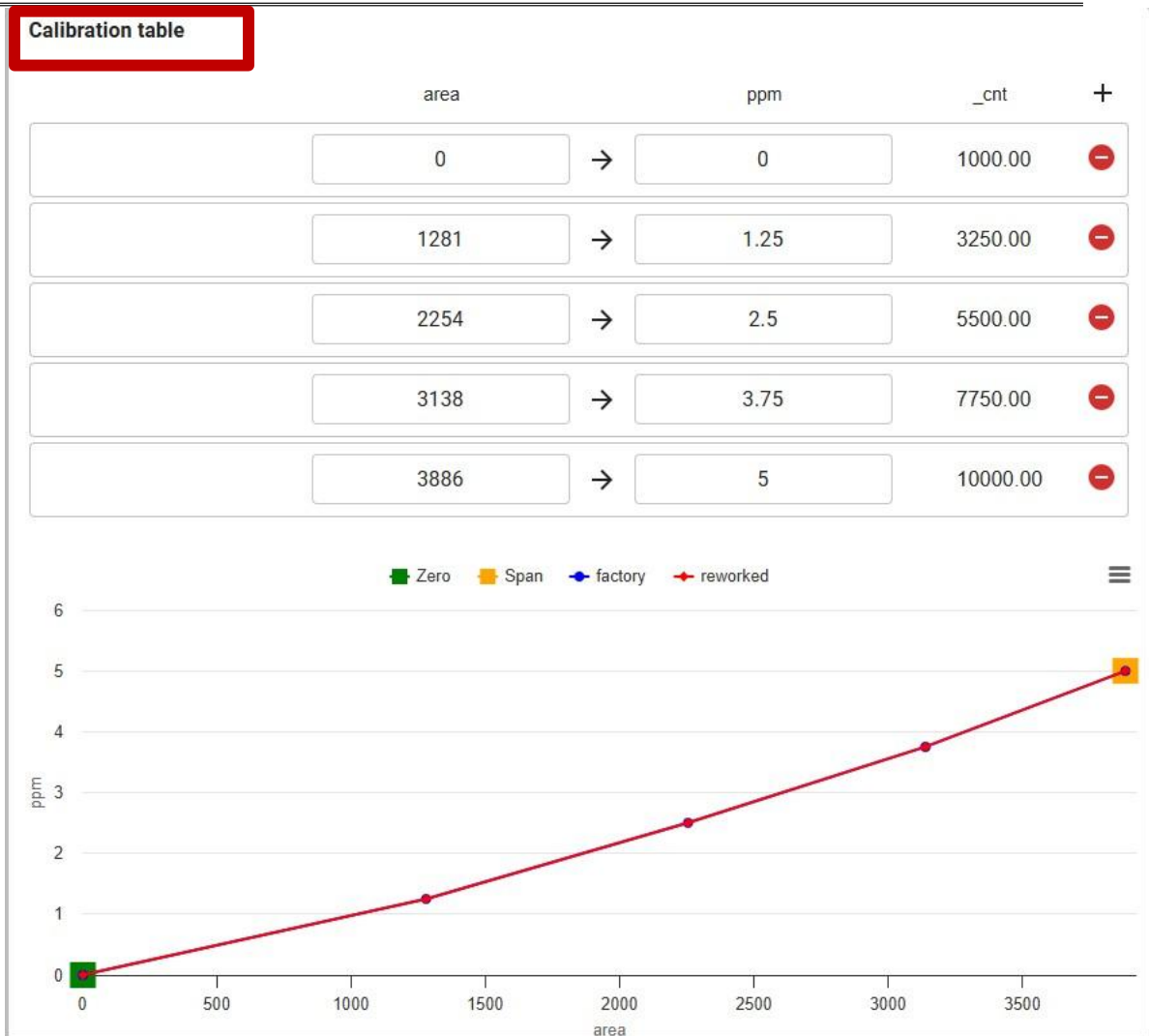

c. Apply calibration:

Once all values are entered, click on Apply to validate the calibration.

**Manual Input**

Components to calibrate

EXPORT CALIB   CANCEL   **APPLY**

4. Calibration validation:

Verify that the calibration has been correctly applied and that the values are stable.

> Last Calibration : 2026-04-13 9:25:00   Note: H2

5. Calibration history:

All calibration actions are saved in the system.

Go to Calibration → Calibration Historic to review previous calibrations.

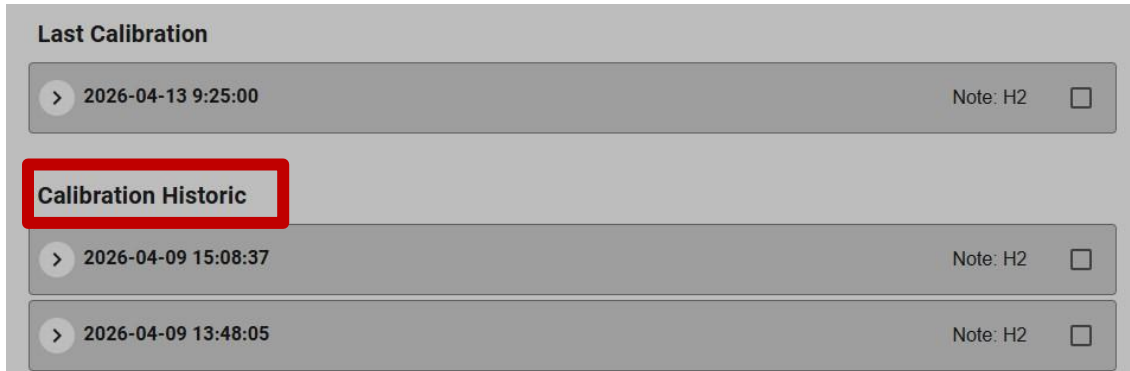

**7.2.5.2. How to automatically calibrate the MultiDetek-Lite with Presets**

Presets can be used to automate the calibration process by defining predefined calibration parameters. This method allows the analyzer to automatically perform zero or span calibration sequences, reducing user intervention and simplifying operation.

This section describes how to configure and use calibration presets on the MultiDetek-Lite.

1. Access calibration menu:

Follow the procedure in section 7.2.1 to switch to the admin mode.

From the bottom navigation bar, click on Calibration, then select the desired method (example: O2). Click on Presets to access the preset configuration interface.

2. Create a new preset:

Click on the “+” button to add a new preset.

3. Configure the preset:

In the preset configuration window:

- Enter a name
- Define the List order if multiple presets are used
- Select the Function:
  - Analysis ReZero for zero calibration
  - Analysis ReSpan for span calibration

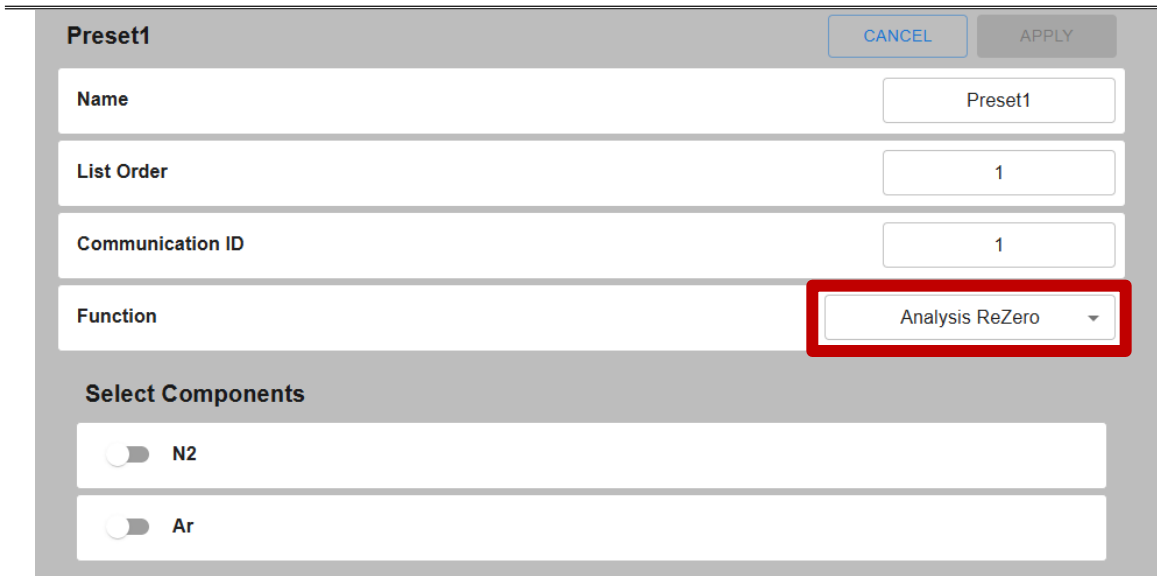

4. Select Components:

- Enable the impurity to calibrate (example: N2, Ar, etc.)
- Enter the appropriate concentration value for each selected impurity.

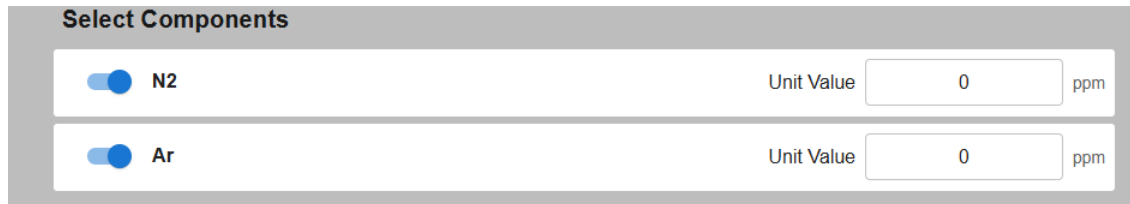

5. Apply and save the preset:

Click on “Apply”



button located at the top of the page to save the preset configuration.

6. Run the preset calibration:

Once the preset is created:

- Go to Home → Calibration → [Method]
- Click on the corresponding Preset button to start the calibration.



7. Calibration execution:

When the calibration starts, a progress indication is displayed on the interface showing the remaining time before calibration.

8. Completion:

Once completed, the calibration is automatically applied and stored in the system.  
You can review calibration results in: Calibration → Calibration Historic.

---

### **7.2.6. How to remotely access the MultiDetek-Lite web interface**

When connected to a network, the MultiDetek-Lite web interface can be accessed from a web browser. This allows you to control, monitor, and troubleshoot the analyzer remotely. Follow the steps below to access the web interface:

1. Click on the analyzer's serial number located in the top-left corner of the screen to open the About Menu.
2. In the About Menu, locate and note the analyzer's IP address.
3. On a computer that is connected to the same network as the analyzer, open a web browser.
4. In the web browser's address bar, type the MultiDetek-Lite's IP address and press Enter.
5. The web browser should now display the MultiDetek-Lite user interface, allowing you to control, monitor, and troubleshoot the analyzer remotely.

### **7.2.7. How to export a machine file**

1. Follow the procedure on section 7.2.1 to switch to the admin mode.
2. Click on the "More" button located in the bottom-left bar of the screen to open the More Menu.
3. In the More Menu, click on "Export Machine".
  - a. When done from the analyzer, the machine file will be saved locally.
  - b. When done from the web interface, the machine file will be saved on the remote computer.

### **7.2.8. How to import a machine file**

1. Follow the procedure on section 7.2.1 to switch to the admin mode.
2. Click on the "More" button located in the bottom-left bar of the screen to open the More Menu.
3. In the More Menu, click on "Import Machine".
4. Import the machine file located on the analyzer or on the remote computer.



---

## 8. Drawings & Schematics

### 8.1. Parts Identification

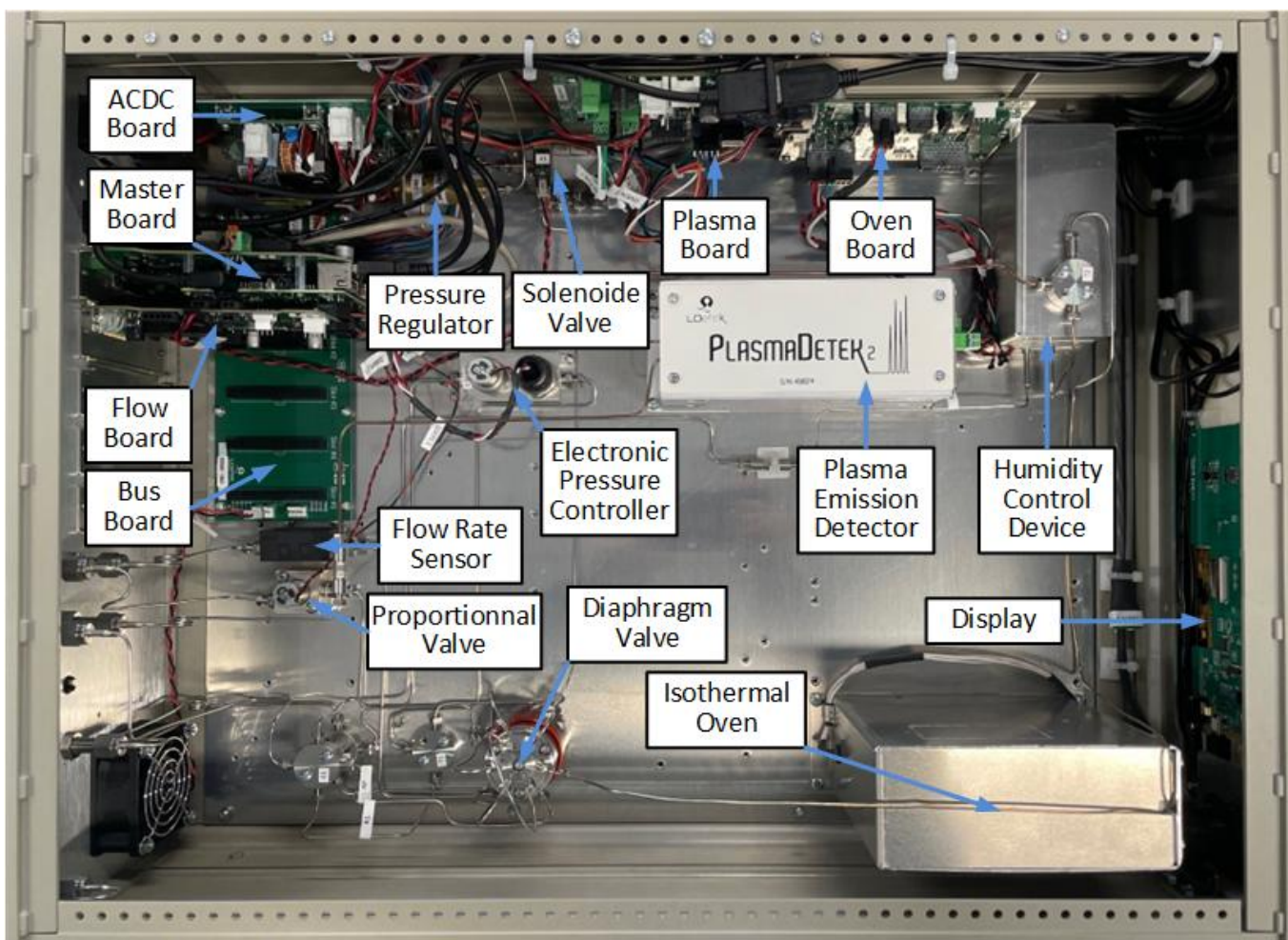

Figure 33: Parts Identification

## 8.2. Back Panel Identification

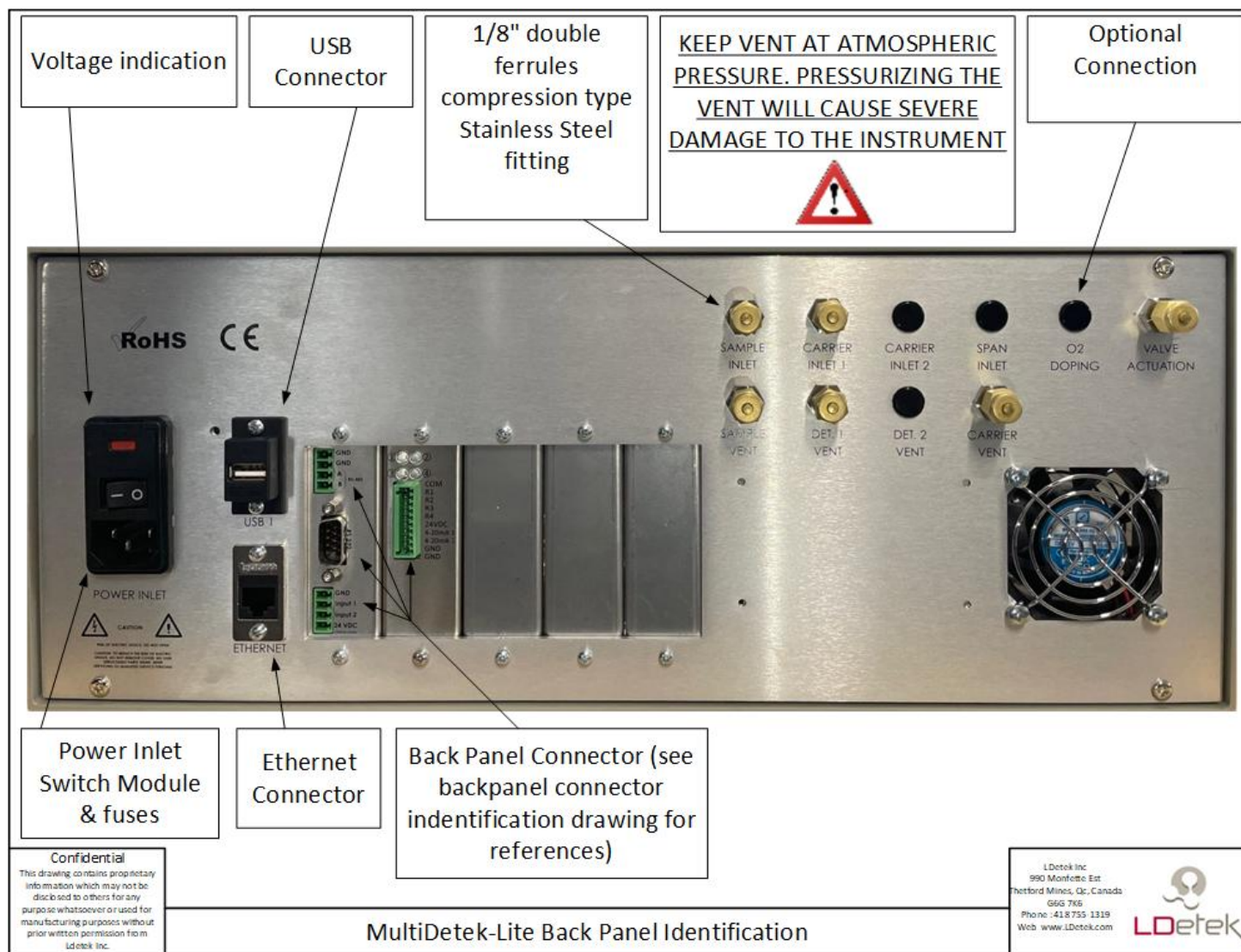
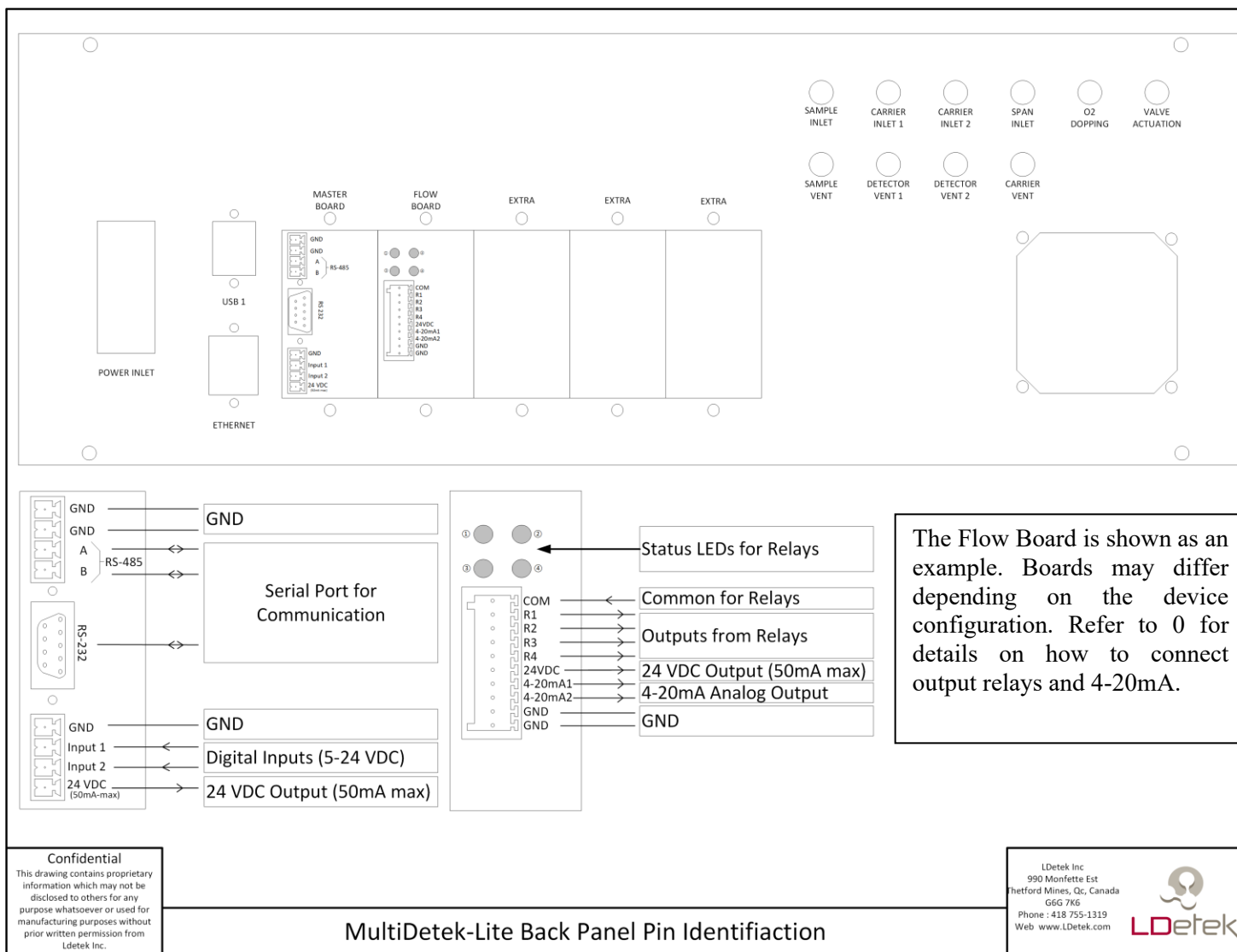

Figure 34: Back Panel Identification

### 8.3. Back Panel Pin Identification



**Confidential**  
This drawing contains proprietary information which may not be disclosed to others for any purpose whatsoever or used for manufacturing purposes without prior written permission from Ldetek Inc.

MultiDetek-Lite Back Panel Pin Identification

LDetek Inc  
990 Monfette Est  
Pretford Mines, Qc, Canada  
G6G 7K6  
Phone : 418 755-1319  
Web : www.LDetek.com



Figure 35: Back Panel Pin Identification

### 8.4. Electrical schematic (block diagram)

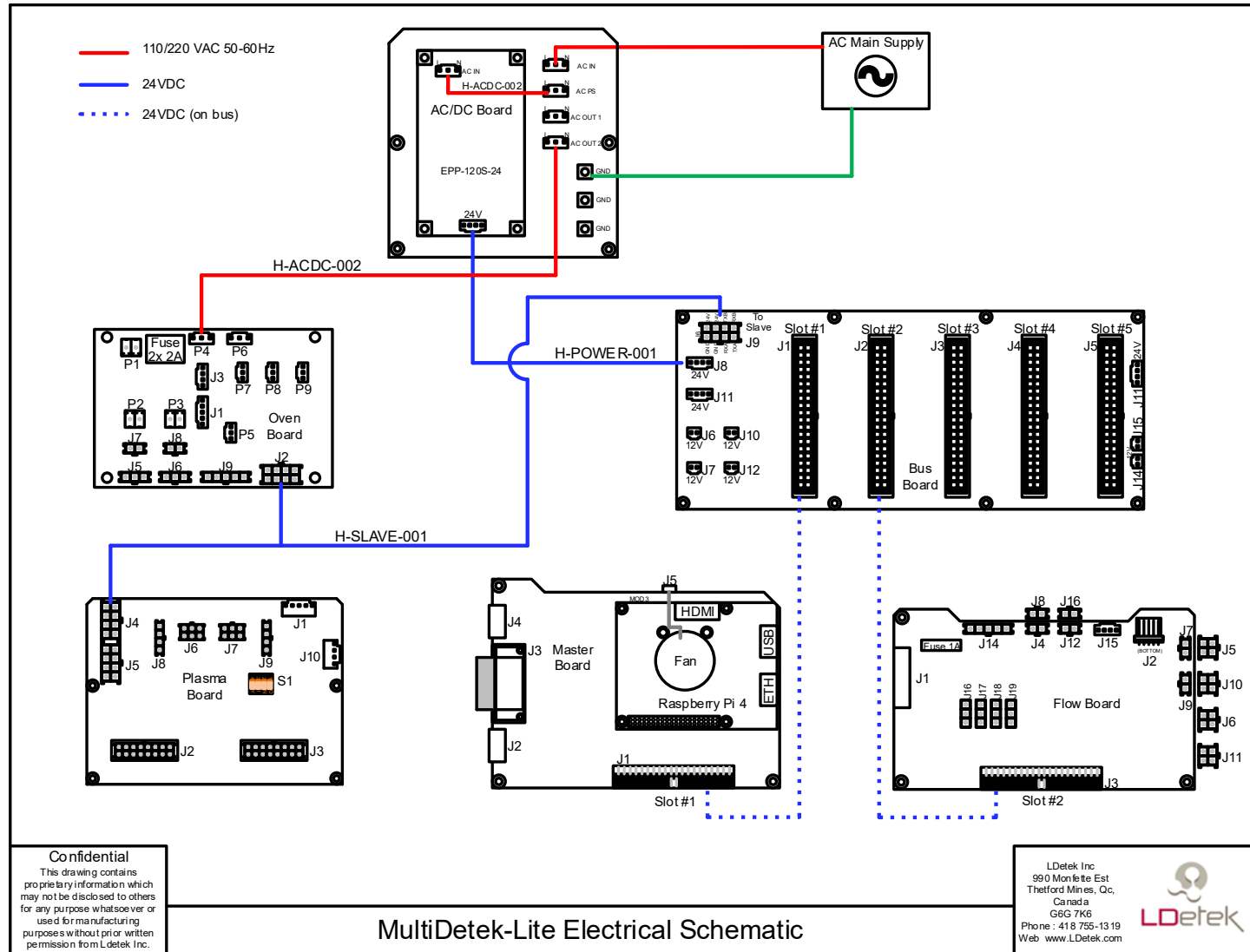

**Confidential**  
This drawing contains proprietary information which may not be disclosed to others for any purpose whatsoever or used for manufacturing purposes without prior written permission from LDetek Inc.

MultiDetek-Lite Electrical Schematic

LDetek Inc  
990 Monfette Est  
Theford Mines, Qc,  
Canada  
G6G 7K6  
Phone : 418 755-1319  
Web www.LDetek.com



Figure 36: Electrical Schematic

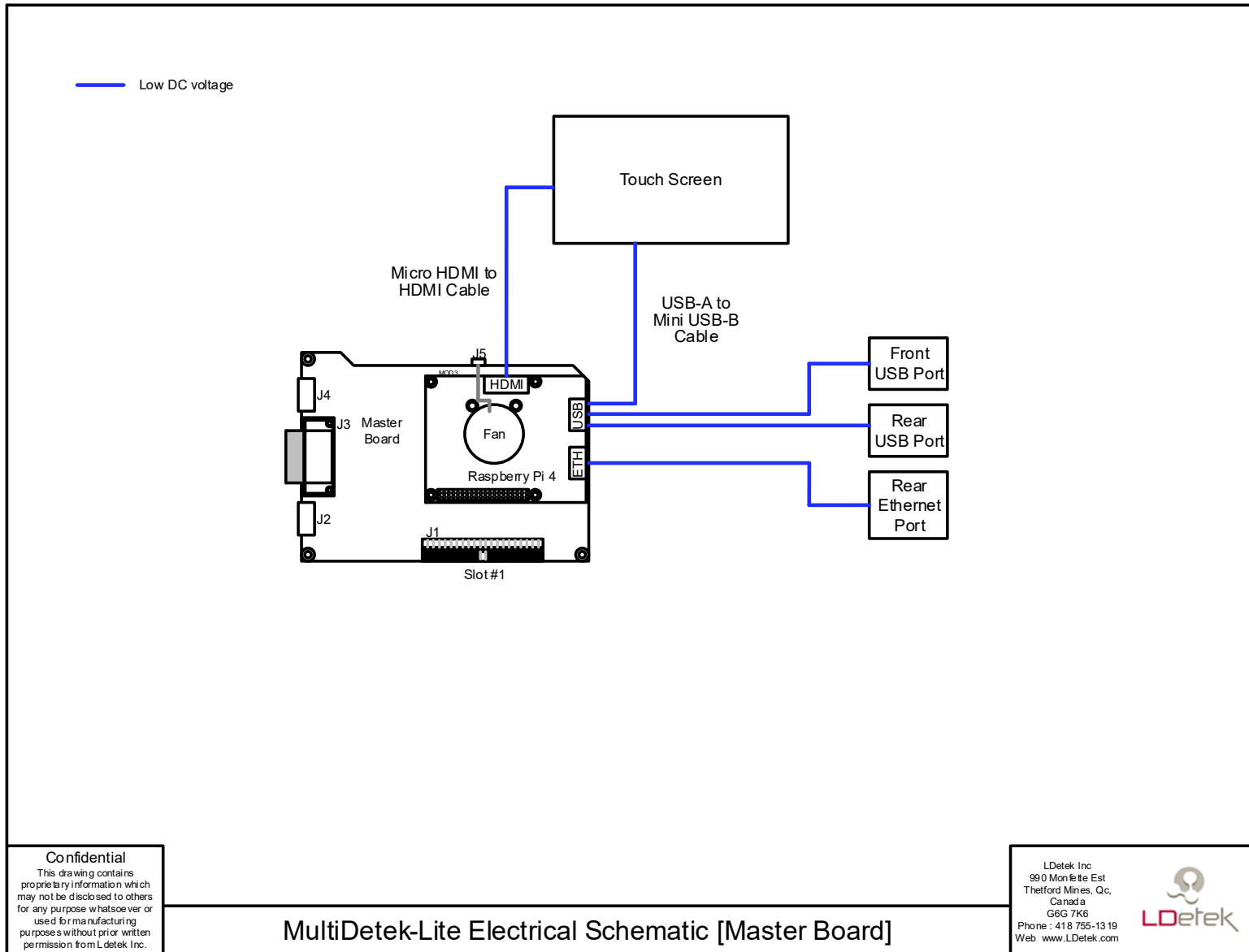
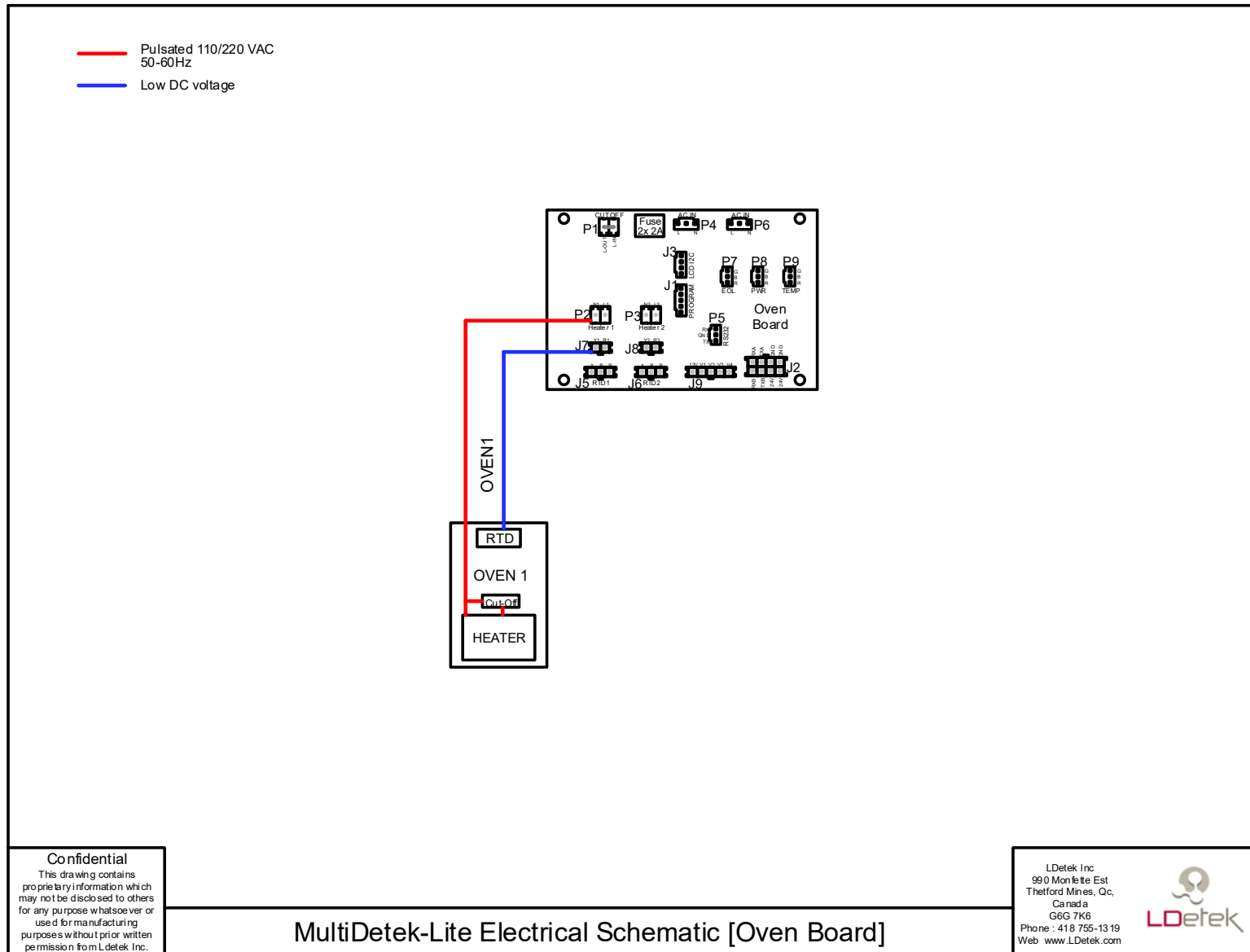

Figure 37: Electrical Schematic [Master Board]



**Confidential**  
 This drawing contains proprietary information which may not be disclosed to others for any purpose whatsoever or used for manufacturing purposes without prior written permission from LDetek Inc.

MultiDetek-Lite Electrical Schematic [Oven Board]

LDetek Inc  
 990 Monfette Est  
 Thetford Mines, Qc,  
 Canada  
 G6G 7K6  
 Phone : 418 755-1319  
 Web www.LDetek.com



Figure 38: Electrical Schematic [Oven Board]

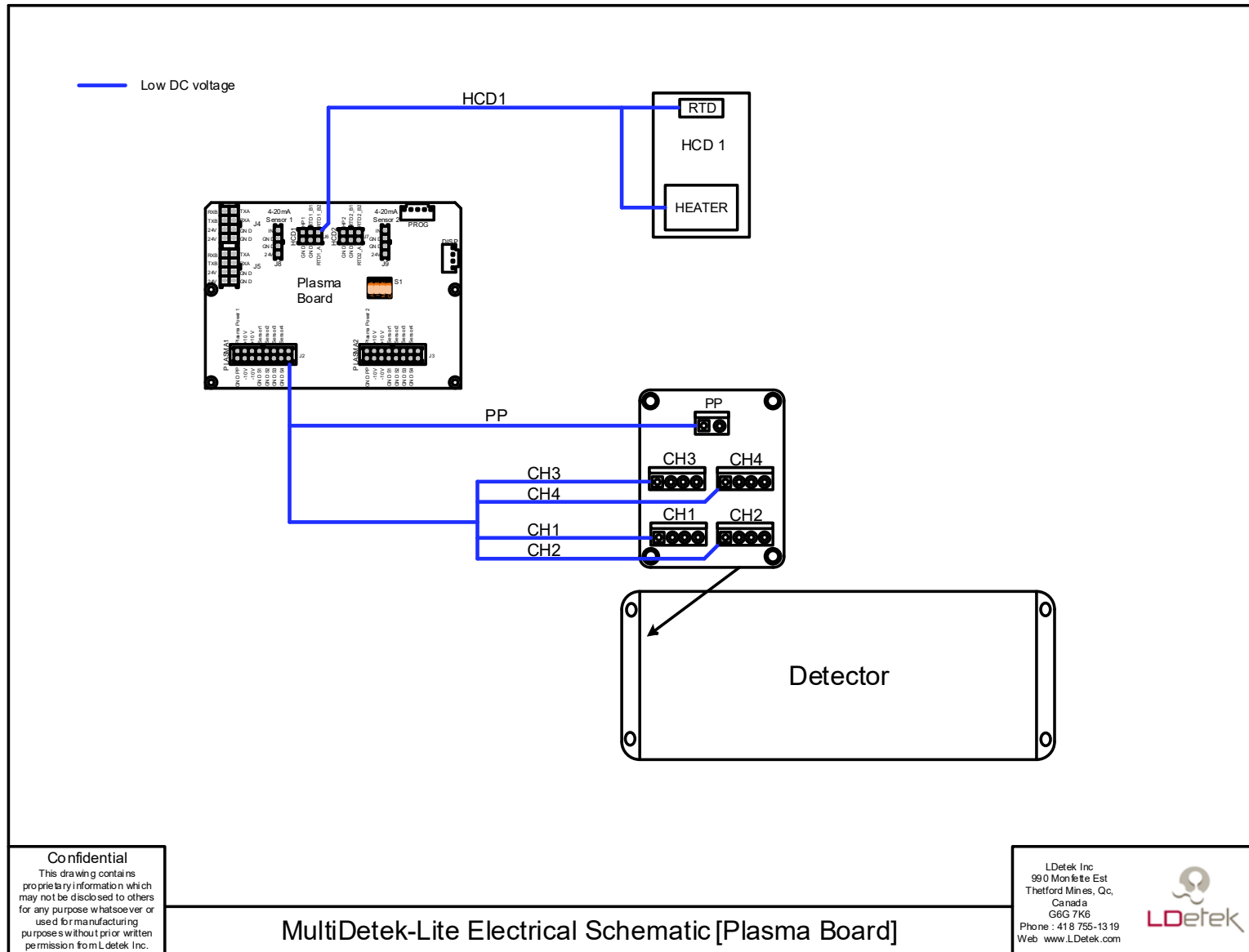
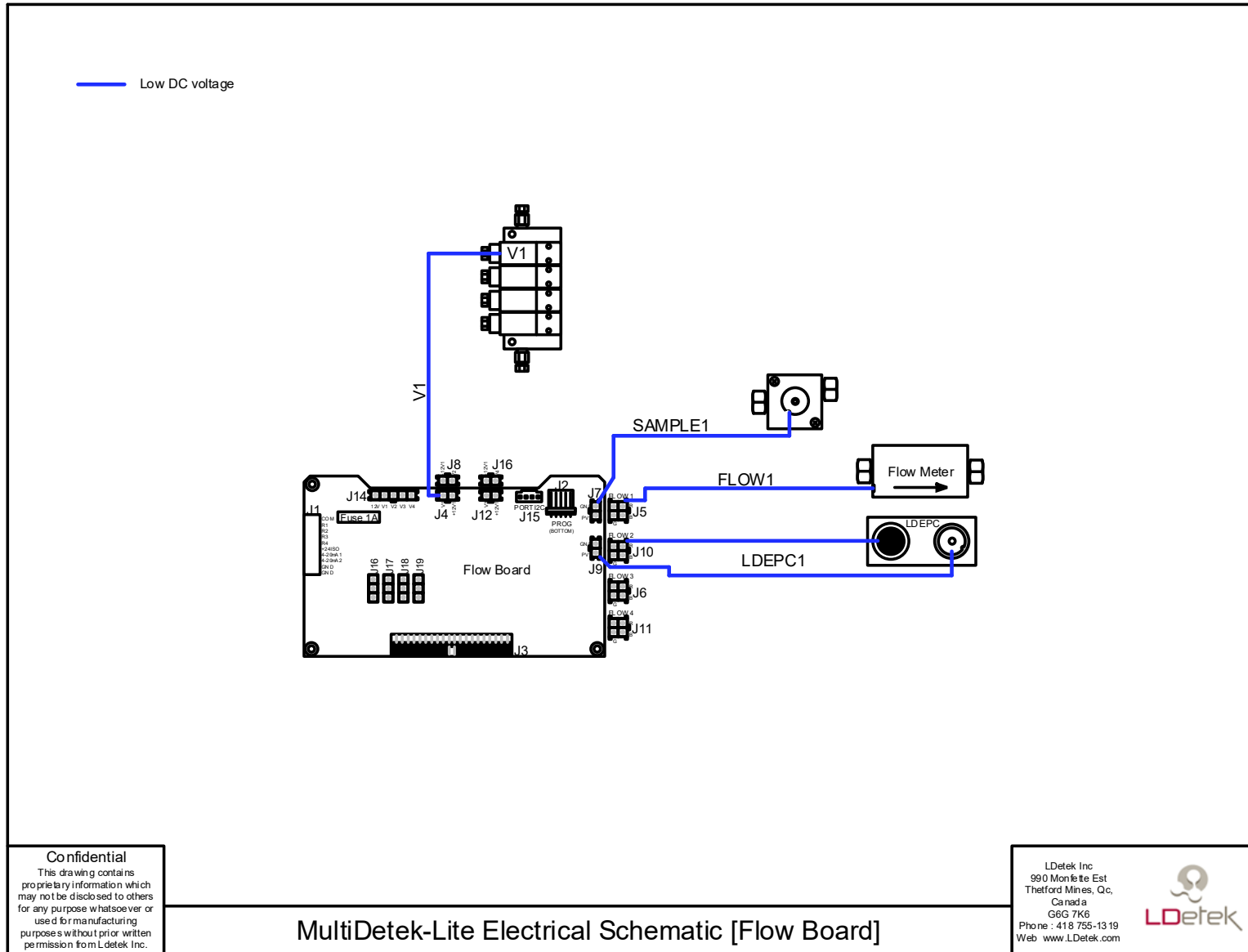

Figure 39: Electrical Schematic [Plasma Board]



**Confidential**  
 This drawing contains proprietary information which may not be disclosed to others for any purpose whatsoever or used for manufacturing purposes without prior written permission from LDetek Inc.

MultiDetek-Lite Electrical Schematic [Flow Board]

LDetek Inc  
 990 Monfette Est  
 Thetford Mines, Qc,  
 Canada  
 G6G 7K6  
 Phone : 418 755-1319  
 Web www.LDetek.com



Figure 40: Electrical Schematic [Flow Board]

## 8.5. Enclosure Dimensions & Panel Cutout

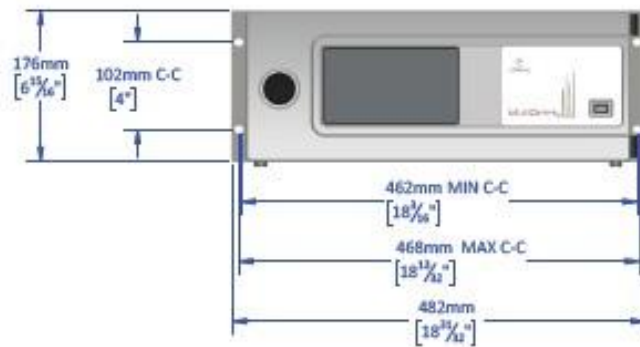
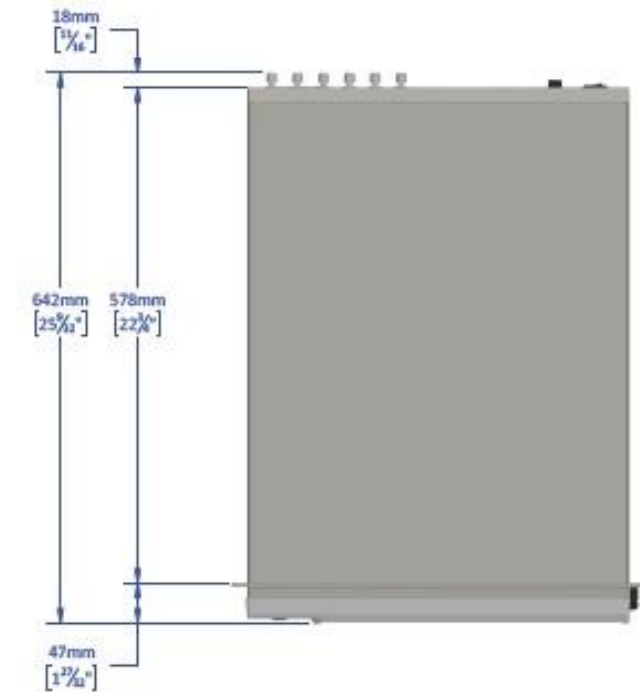

## 9. Maintenance and troubleshooting

Every MultiDetek-Lite is custom-built, therefore, the maintenance requirements will vary from system to system. Feel free to contact LDetek at [support@ldetek.com](mailto:support@ldetek.com). if you need the maintenance schedule specific to your analyzer.

### 9.1. Spare part list

The below table shows consumables and capital spare parts that can be required in a MultiDetek-Lite. Consumables are parts that will deteriorate over time and must be replaced periodically. For most MultiDetek-Lite, preventive maintenance must be scheduled every 3 to 5 years to replace these consumables.

Capital parts on the other hand, are parts that are known to have a long life and/or a small chance of failure. However, failure would cause a shutdown of the equipment because it would take some time to get a replacement part.

The below table shows all the parts that could be required for a MultiDetek-Lite. However, depending on its configuration, some parts might not be required for your system. For instance, Vpump-MDL is a vacuum pump only required for systems using Nitrogen as the carrier gas. Therefore, this part is not required if your analyzer is using another type of carrier gas. Please contact LDetek to get a list of parts specific to your system.

Part #	Description	Type	Replacement frequency
D2-MDL	Replacement diaphragm for 2 streams valve (or O2 doping valve)	Consumable	3-5 years
D3-MDL	Replacement diaphragm for 3 streams valve	Consumable	3-5 years
D4-MDL	Replacement diaphragm for 4 streams valve	Consumable	3-5 years
D6-MDL	Replacement diaphragm for 6 ports valve	Consumable	3-5 years
D10-MDL	Replacement diaphragm for 10 ports valve	Consumable	3-5 years
DQMA-MDL	Replacement diaphragm for QMA's valve	Consumable	3-5 years
THCDFS-MDL	Replacement Tempered Humidity Control Device (HCD - Face seal Version)	Consumable	3-5 years
FanK-MDL	Replacement fan	Consumable	3-5 years
Vpump-MDL	Pump for analyzers with Nitrogen Carrier	Consumable	3-5 years
MSP-MDL	Pump for analyzers with low sample pressure	Consumable	3-5 years
Compact-LDP1000,	Purifier for carrier gas	Consumable	3-5 years

LDP1000 or Large-LDP1000			
TCD-filament-MDL	Standard TCD filament	Consumable	3-5 years
TCDgold-filament-MDL	Gold-plated TCD filament	Consumable	3-5 years
Collector-MDL	Collector electrode for FID	Consumable	3 years
Iso-Oven-MDL	Isothermal oven	Capital part	N/A
FSM-MDL	Flow sensor for carrier gas or sample gas + PCB	Capital part	N/A
LDEPC-MDL	Electronic flow controller (LDEPC+PCB)	Capital part	N/A
LCD-MDL	TFT LCD display for MDL	Capital part	N/A
PED-MDL	Plasma module for MDL	Capital part	N/A
SV-MDL	Solenoid valve 12 VDC for MD3	Capital part	N/A

## 9.2. Tools

Some tools are required when doing a start-up, maintenance or troubleshooting on the MultiDetek-Lite. The below table shows the list of tools that may be useful. These tools are separated into 2 categories – general and repair.

Tools in the category general are useful to do common tasks like start-ups, shut-offs or maintenance. For advanced users that intend to do repair tasks, tools in the category repair will be useful. Please note that to perform repairs, tools from the category general are required.

Part #	Description	Category
ScrewdriverPH2	Philips screwdriver #2	General
Wrench1/4	Wrench 1/4"	General
Wrench3/8	Wrench 3/8"	General



## MultiDetek-Lite User's manual

Wrench7/16	Wrench 7/16"	General
Flowmeter500ml	Flow meter 0-500ml/min	General
AngledWrench1/4	Angled wrench 1/4 for 1/16 fittings (10/32 thread)	General
Torkwrench	Tork wrench Wiha for valve screws	General
7/64"Hex Allen Key	7/64" Hex Allen Key for valve screws	General
9/64"Hex Allen Key	9/64" Hex Allen Key for valve screws	General
1/16TubeCuttingTool	1/16" Tube Cutting tool. Used to cut 1/16" tubing inside the analyzer.	Repair
FittingPliers	C-vice grip (4LW) 1/16 fittings pliers.	Repair
RestrictorPliers	Channellock909 reworked for orifices adjustment.	Repair
5/64"Hex Allen Key	5/64" Hex Allen Key for LDepc adjustment.	Repair

---

### 9.3. Maintenance procedures

This section provides maintenance procedures. Because every MultiDetek-Lite is custom-built, the procedures can vary slightly from system to system. Feel free to contact LDetek at [support@ldetek.com](mailto:support@ldetek.com), if you need clarifications.

#### 9.3.1. How to replace the HCDs

1. Turn off the MultiDetek-Lite by putting the power switch off.
2. With a Philips screwdriver, unscrew the 4 screws that are holding the top cover. There are 2 screws on each side of the analyzer.
3. Remove the 2 screws on each side of the HCD box.
4. Carefully remove the HCDs from the box. The heater should be screwed on the HCD, and the temperature sensor will be mounted inside.
5. Remove the heater by unscrewing it from the stainless block and pull out the temperature sensor.
6. Remove the inlet and outlet of the HCD module using a wrench 7/16". The face seal gasket should fall out and you can discard it.
7. Place new gaskets on the new HCD and connect the inlet/outlet.
8. Re-install the temperature sensor and the heater on the new HCD.
9. Reinstall the HCD in its box and put back the 2 screws.
10. Power on the analyzer and wait 24 hours and before performing a calibration check.

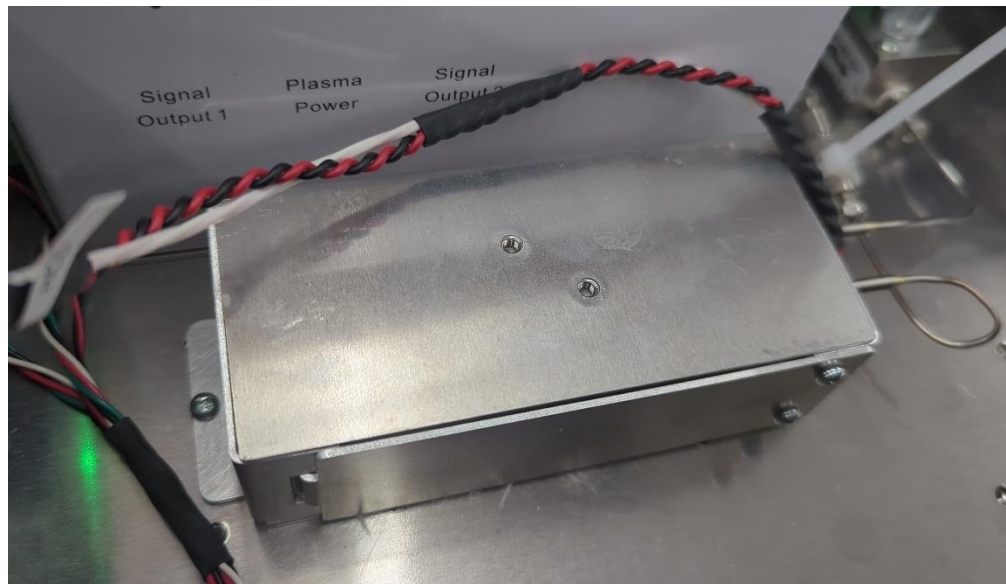

Figure 41: HCD box

#### 9.3.2. How to replace the fan in a MultiDetek-Lite

1. Turn off the MultiDetek-Lite by putting the power switch off.

2. With a Philip screwdriver, unscrew the 4 screws that are holding the top cover. There are 2 screws on each side of the analyzer.
3. You will then have access to the fan located on the back. Disconnect the white connector on the bus board to remove the power from the fan.
4. Remove the fixing screws and replace the fan with a new one.
5. Reconnect the white connector and close the top cover.

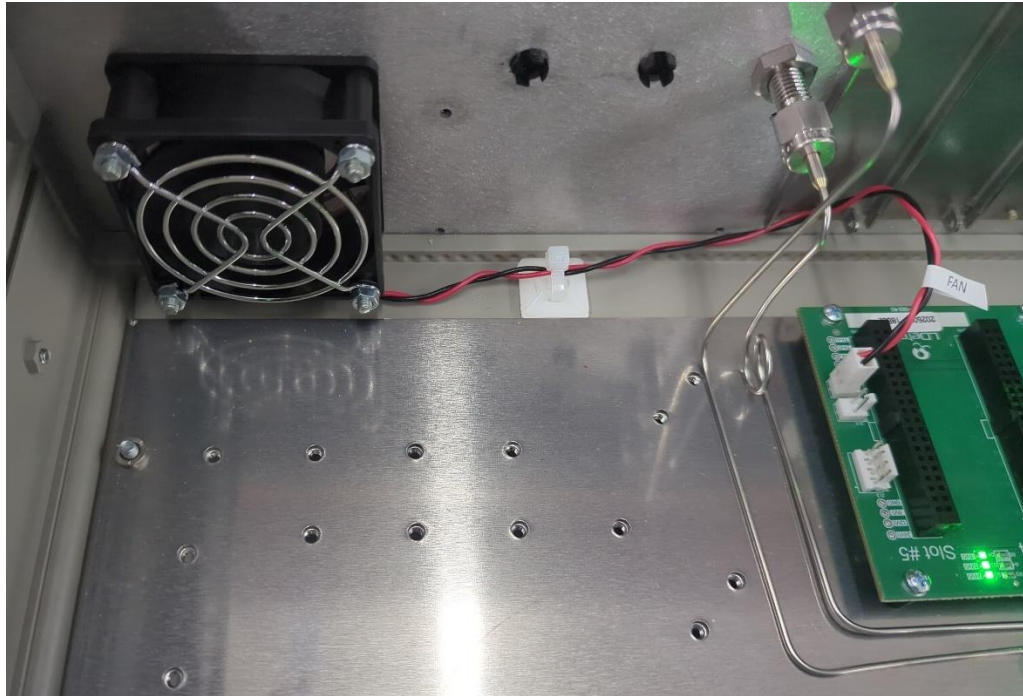

Figure 42: MultiDetek-Lite fan

### 9.3.3. How to calibrate the 4-20mA module

The Analog Output has already been calibrated by LDetek before and shouldn't be recalibrated under normal circumstances. In the eventuality that the Analog Output must be recalibrated, the procedure below explains how to proceed with the 4-20mA calibration.

1. Go to Home > Settings and click on 4-20mA1.



2. Click on "Calib 4mA" and measure the current on the MultiDetek-Lite back panel. If needed, refer to the drawing on section 8.3.

Calib 4mA	
Calib 20mA	
Force Value / Reset Force	<input type="button" value="FORCE VALUE"/> <input type="button" value="RESET FORCE"/>

3. Enter the value you measured and click on “Apply”.

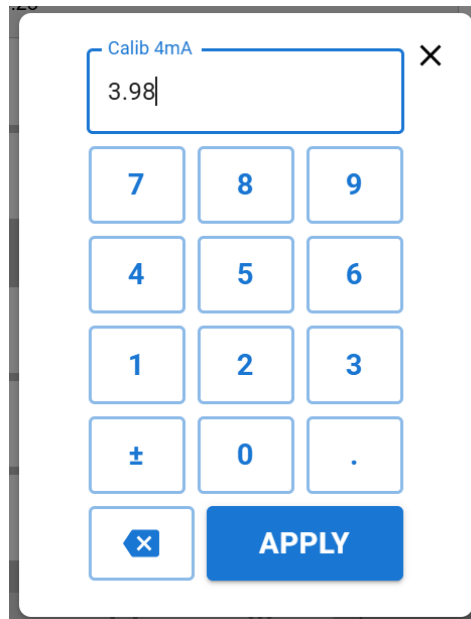

Calib 4mA

3.98

7 8 9

4 5 6

1 2 3

± 0 .

⌫ APPLY

4. Repeat step 2 and 3 for 20mA.
5. Once done, you can test the calibration by clicking on “Force Value”. Note that you must click on “Reset Force” when done.

### 9.3.4. How to replace the diaphragm in a MultiDetek-Lite

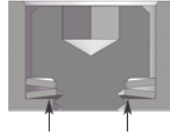
<p><b>Diaphragm replacement procedure.</b></p> <p>The diaphragm replacement procedure is the same for six and ten port valves. If your valve has relief pin holes in the cylinder body, just follow the steps that refer to these pins. Skip those steps if your valve doesn't have these holes in the cylinder body.</p> <div style="background-color: #800000; color: white; padding: 5px;"> <p><b>! WARNING</b> Shut off carrier and sample gas before proceeding. If hydrogen, oxygen, or other hazardous gases are flowing into the valve, evacuate them by allowing inert gas to flow through the valve, make sure that no toxic or hazardous gas will leak into your working area.</p> </div> <p><b>Note:</b> A visual inspection is necessary and recommended while the valve cap and the diaphragm are removed from the valve body. If there is any trace of contaminant on the valve cap wetted surface it must be cleaned following cleaning procedure.</p>	<p><b>Step 1</b> Skip this step if your valve doesn't have relief pins. Actuate the valve by pressurizing the actuator (ON position). When the actuator is pressurized, insert the relief pins into their respective holes as shown in figure 1. You may need to slightly increase the actuation pressure to ease the pins in. When the pins are properly inserted, depressurize the actuator (OFF position). This step makes sure that all the plungers are down, making it easier to install the diaphragm and properly align it.</p> <p><b>Step 2</b> Unscrew first the three screws mounted on the outer edge of the valve cap and then unscrew the middle screw.</p> <p><b>Note:</b> The screw mounted in the middle of the valve cap is longer than the other ones. It must be re-installed at the same place.</p> <p><b>Step 3</b> Carefully lift the valve cap.</p> <p><b>Note:</b> Don't touch the valve cap surface with your fingers.</p> <p><b>Step 4</b> With the help of a small and clean plastic tweezers remove the used diaphragm.</p> <p><b>Step 5</b> Remove the new diaphragm from the plastic bag. With the help of a small clean plastic tweezers install the diaphragm in place. Make sure that the diaphragm groove is aligned with the recess in the cylinder body.</p> <p><b>Note:</b> Manipulate the diaphragm only by its edge. Don't touch the process area with your fingers or dirty tools. This will affect the detector baseline and/or contaminate column.</p>	 <p style="text-align: center;">Figure 1</p>	<p><b>Step 6</b> Re-install the valve cap on the cylinder body by aligning the cylinder dowel pins with valve cap corresponding holes and gently depress the valve cap on the diaphragm. Make sure that the counter bore on the valve cap for the screws are aligned with the screws are aligned with the threads in the cylinder body.</p> <p><b>Note:</b> If you feel any resistance, you may not be aligned properly.</p> <p><b>Step 7</b> Re-install the four mounting screws by beginning with the longer one that must be installed in the center hole of the valve cap. Tighten this screw to 5 lb-in (0.6 N-m) using a proper torquing tool and then continue with the 3 other ones.</p> <p><b>Note:</b> Make sure to have two compression washers per screw installed in the proper position.</p>  <p><b>Step 8</b> Tighten first the center screw to exactly 20 lb-in (2.3 N-m) using a proper torquing tool and then continue with the 3 other ones.</p> <p><b>Step 9</b> Skip this step if your valve doesn't have relief pins. Re-pressurize the actuator and remove the relief pins.</p> <p><b>Step 10</b> The valve is now ready to be used.</p>
--	---	--	---

### 9.3.5. How to replace a purifier with a MultiDetek-Lite

1. Note the sensor's signal shown in the menu diagnostic.

<b>Sensor1</b> Analog Input	Filtered value	1517.13 mV
	Unit value	1517.13 mV
<b>Sensor2</b> Analog Input	Filtered value	3995.10 mV
	Unit value	3995.10 mV

2. Power off the old purifier and remove the power cable.
3. Remove the new purifier from the shipping box and protective wrapping. Make sure that both end caps are tight, and that the unit is in good condition. Also, make sure that the specifications match the old purifier (voltage, fittings type and gas type).
4. Disconnect the old purifier from the carrier gas line.
  - a. If your system has in, out and bypass valves, close the in/out and open the bypass valve. Then, disconnect the inlet and outlet fittings to remove the purifier.
  - b. If your system only has an inlet valve, close it to stop the carrier flow. Then, disconnect the inlet and outlet fittings to remove the purifier. The following steps must be done quickly to avoid contaminating the MultiDetek-Lite with Air.
  - c. If your system does not have valves, close the carrier from the source. Then, disconnect the inlet and outlet fittings to remove the purifier. The following steps must be done quickly to avoid contaminating the MultiDetek-Lite with Air.
5. Connect the new purifier by starting with the inlet fitting.
  - a. If your system has in, out and bypass valves, you can now open the in/out and close the bypass valve.
  - b. If your system only has an inlet valve, you can re-open it once both fittings are connected.
  - c. If your system does not have valves, you can re-open the carrier gas source.
6. Let the purifier purge for about 30 min. Then re-connect the power cable and power it on.
7. Wait 2-4 hours and check the voltages again. If they are not close to the values from point 1, feel free to contact LDefek at [support@ldetek.com](mailto:support@ldetek.com).

## 9.4. Troubleshooting

### 9.4.1. Alarm list

Alarm name	Description
Flow deviation on "FlowID"	This alarm shows that the flow of a specific module deviates from the setpoint.
Temperature deviation on "OvenID"	This alarm shows that the temperature of a specific oven deviates from the setpoint.
Detector off on "DetectorID"	This alarm indicates that the detector is not powered ON.
Temperature out of bounds	This alarm indicates that the temperature measurement is outside of the sensor's limits. This generally happens if the sensor is disconnected or malfunctioning.
Flow out of bounds	This alarm indicates that the flow measurement is outside of the sensor's limits. This generally happens if the sensor is disconnected or malfunctioning.

### 9.4.2. Low flow/flow deviation on sample

1. Check if the sample flow setpoint matches the value in the document operating parameters. The flow setpoint can be found in the menu Settings>> Flow>>Sample.
2. Check if the sample pressure matches the value in the document operating parameters. It should be 5-30 psig for most systems.
3. Measure the flow with a flow meter connected to the sample vent of the MultiDetek-Lite.
4. Contact LDeftek support ([support@ldetek.com](mailto:support@ldetek.com)) with the results obtained in the previous steps.

### 9.4.3. Low flow/flow deviation on LDepc

1. Check if the carrier pressure matches the value in the document operating parameters. Typically, this pressure is set to 100 psig (7 bars).
2. Increase the carrier pressure by 10 PSIG to see if the carrier flow stabilizes on the setpoint.
3. Put back the carrier pressure at the value in the operating parameters to see if the

flow stabilizes on the setpoint.

4. Decrease the carrier pressure by 10 PSIG to see if the carrier flow stabilizes on the setpoint.
5. Try to bypass the gas purifier to see if the carrier setpoint comes back to normal.
6. Contact LDefek support ([support@ldetek.com](mailto:support@ldetek.com)) with the results obtained in the previous steps.

#### **9.4.4. Oven temperature deviation**

1. Check if the carrier pressure matches the value in the document operating parameters.
2. Open the front door and check if the green connectors for each oven are well connected.
3. Contact LDefek support ([support@ldetek.com](mailto:support@ldetek.com)) with the results obtained in the previous steps.

#### **9.4.5. Detector off**

1. Check if the raw signals for the sensors match the values shown in the document "Operating Parameters".
2. Open the front door and check if the connectors on the detectors are well connected.
3. Contact LDefek support ([support@ldetek.com](mailto:support@ldetek.com)) with the results obtained in the previous steps.

#### **9.4.6. Lost peaks**

1. Check if there are flow alarms and resolve them.
2. Check if there are temperature deviation alarms and resolve them.
3. Check if the raw signals for the sensors match the values shown in the document "Operating Parameters".
4. Contact LDefek support ([support@ldetek.com](mailto:support@ldetek.com)) with the results obtained in the previous steps.

#### **9.4.7. Defective 4-20mA module**

1. Recalibrate the defective module.
2. Contact LDefek support ([support@ldetek.com](mailto:support@ldetek.com)) with the results obtained in the previous steps.

#### **9.4.8. Unstable measurements**

1. Make sure that there is no active alarm. If there are alarms, they must be resolved.

2. Make sure that the calibration has been done properly.
3. Contact LDetek support ([support@ldetek.com](mailto:support@ldetek.com)) with the results obtained in the previous steps.











**LD**etek

Where **innovation** leads to **success**