

USER MANUAL

S8000 HT

Chilled Mirror Hygrometer



Please fill out the form(s) below for each instrument that has been purchased.

Use this information when contacting Michell Instruments for service purposes.

| | |
|-----------------------|--|
| Product Name | |
| Order Code | |
| Serial Number | |
| Invoice Date | |
| Installation Location | |
| Tag Number | |

| | |
|-----------------------|--|
| Product Name | |
| Order Code | |
| Serial Number | |
| Invoice Date | |
| Installation Location | |
| Tag Number | |

| | |
|-----------------------|--|
| Product Name | |
| Order Code | |
| Serial Number | |
| Invoice Date | |
| Installation Location | |
| Tag Number | |



S8000 HT

For Michell Instruments' contact information please go to
www.ProcessSensing.com

© 2026 Michell Instruments

This document is the property of Michell Instruments Ltd and may not be copied or otherwise reproduced, communicated in any way to third parties, nor stored in any Data Processing System without the express written authorization of Michell Instruments Ltd.

Contents

| | |
|---|------|
| Safety..... | vii |
| Electrical Safety..... | vii |
| Pressure Safety..... | vii |
| Toxic Materials..... | vii |
| Repair and Maintenance..... | vii |
| Calibration..... | vii |
| Safety Conformity..... | vii |
| Abbreviations..... | viii |
| Warnings..... | viii |
| | |
| 1 Introduction..... | 1 |
| 1.1. Operating Principle..... | 1 |
| 2 Installation..... | 2 |
| 2.1. Safety..... | 2 |
| 2.2. Unpacking the Instrument..... | 2 |
| 2.3. Positioning..... | 3 |
| 2.4. Connecting the Instrument..... | 4 |
| 2.5. Operating Requirements..... | 5 |
| 2.5.1. Environmental Requirements..... | 5 |
| 2.5.2. Electrical Requirements..... | 5 |
| 2.5.2.1. Front Panel..... | 6 |
| 2.5.2.2. Rear Panel Connections..... | 7 |
| 2.5.3. Power Supply Input..... | 8 |
| 2.5.4. Analog Output Connections..... | 9 |
| 2.5.5. Alarm Output Connections..... | 10 |
| 2.5.6. Remote Temperature Probe..... | 10 |
| 2.5.7. USB Communications Port Connector..... | 11 |
| 2.5.8. Ethernet/RS485 Port (optional)..... | 12 |
| 3 OPERATION..... | 13 |
| 3.1. General Operational Information..... | 13 |
| 3.1.1. Sample Flow Adjustment..... | 13 |
| 3.2. Operational Functions..... | 14 |
| 3.2.1. Operating Cycle..... | 14 |
| 3.3. Operating Guide..... | 15 |
| 3.3.1. Remote Temperature Probe..... | 15 |
| 3.3.2. Sensor Temperature and HTL Control..... | 15 |
| 3.3.2.1. Operating Practice..... | 15 |
| 3.3.3. Shutdown Procedure..... | 16 |
| 3.3.4. DCC – Dynamic Contamination Control..... | 16 |
| 3.3.5. MAXCOOL Function..... | 16 |
| 3.3.6. Pressure Transmitter Input..... | 16 |
| 3.3.7. Data Logging..... | 17 |
| 3.3.8. Frost Assurance Technology (FAST)..... | 17 |
| 3.3.9. STANDBY Mode..... | 17 |
| 3.4. User Interface..... | 18 |
| 3.4.1. Main Screen..... | 18 |
| 3.4.2. Customizable Readouts..... | 18 |
| 3.4.2.1. Full-Screen Mode..... | 19 |
| 3.4.3. Operational Status Display..... | 20 |
| 3.4.4. Sensor/HTL Setup..... | 21 |
| 3.4.5. Setup Menu Screen..... | 22 |
| 3.4.6. Menu Structure..... | 24 |
| 3.4.7. DCC..... | 25 |
| 3.4.8. LOGGING..... | 26 |
| 3.4.9. OUTPUTS..... | 26 |
| 3.4.10. ALARM..... | 28 |
| 3.4.11. DISPLAY..... | 29 |
| 3.4.12. CLOCK..... | 30 |
| 3.4.13. Inputs..... | 30 |
| 3.4.14. Comms..... | 31 |
| 3.4.15. Network Settings..... | 31 |
| 3.4.16. Extended Settings..... | 32 |

| | | |
|------|------------------------------|----|
| 4 | Warnings and Faults | 33 |
| 4.1. | Fault Codes | 34 |
| 5 | Maintenance..... | 35 |
| 5.1. | Sensor Mirror Cleaning | 35 |
| 5.2. | Fuse Replacement..... | 36 |
| 6 | Application Software..... | 37 |

Tables

| | | |
|----------|------------------------------------|----|
| Table 1 | Front Panel Controls..... | 6 |
| Table 2 | Rear Panel Connections | 8 |
| Table 3 | Main Screen Description..... | 18 |
| Table 4 | Operational Status Display | 20 |
| Table 5 | Sensor/HTL Setup Parameters | 21 |
| Table 6 | DCC Parameters | 25 |
| Table 7 | Logging Parameters..... | 26 |
| Table 8 | Outputs Parameters..... | 27 |
| Table 9 | Alarm Parameters..... | 28 |
| Table 10 | Display Parameters | 29 |
| Table 11 | Clock Parameters | 30 |
| Table 12 | Inputs Parameters | 30 |
| Table 13 | Comms Parameters | 31 |
| Table 14 | Network Parameters | 31 |
| Table 15 | Extended Settings Parameters | 32 |

Figures

| | | |
|-----------|---|----|
| Figure 1 | Operating Principle..... | 1 |
| Figure 2 | Front Panel..... | 6 |
| Figure 3 | Rear Panel..... | 7 |
| Figure 4 | Alarm and Analog Output Connection..... | 9 |
| Figure 5 | USB Port Connection..... | 11 |
| Figure 6 | Ethernet Port..... | 12 |
| Figure 7 | RS485 Port (optional)..... | 12 |
| Figure 8 | Typical Operating Cycle..... | 14 |
| Figure 9 | Main Screen..... | 18 |
| Figure 10 | Sensor/HTL Setup Screen..... | 21 |
| Figure 11 | Setup Menu Screen..... | 22 |
| Figure 12 | Virtual Keyboard..... | 23 |
| Figure 13 | Menu Structure..... | 24 |
| Figure 14 | DCC Screen..... | 25 |
| Figure 15 | Logging Screen..... | 26 |
| Figure 16 | Outputs Screen..... | 27 |
| Figure 17 | Alarm Screen..... | 28 |
| Figure 18 | Display Screen..... | 29 |
| Figure 19 | Clock Screen..... | 30 |
| Figure 20 | Inputs Screen..... | 30 |
| Figure 21 | Comms Screen..... | 31 |
| Figure 22 | Network Settings Screen..... | 31 |
| Figure 23 | Extended Settings Screen..... | 32 |
| Figure 24 | System Alarm Screen..... | 33 |

Appendices

| | | |
|------------|--|----|
| Appendix A | Technical Specifications..... | 37 |
| | A.1 Dimensions..... | 38 |
| Appendix B | Modbus Register Map..... | 40 |
| Appendix C | Quality, Recycling & Warranty Information..... | 49 |
| Appendix D | Return Document & Decontamination Declaration..... | 51 |

Safety

The manufacturer has designed this equipment to be safe when operated using the procedures detailed in this manual. The user must not use this equipment for any other purpose than that stated. Do not apply values greater than the maximum value stated; the protection will be impaired if the equipment is used in a manner not specified by the manufacturer.

This manual contains operating and safety instructions, which must be followed to ensure the safe operation and to maintain the equipment in a safe condition. The safety instructions are either warnings or cautions issued to protect the user and the equipment from injury or damage. Use competent personnel using good engineering practice for all procedures in this manual.

Electrical Safety

The instrument is designed to be completely safe when used with options and accessories supplied by the manufacturer for use with the instrument.

Pressure Safety

DO NOT permit pressures greater than the safe working pressure to be applied to the instrument. The specified maximum working pressure is 0.5 barg (7.25 psig). Refer to the Technical Specifications in Appendix A.

Toxic Materials

The use of hazardous materials in the construction of this instrument has been minimized. During normal operation it is not possible for the user to come into contact with any hazardous substance which might be employed in the construction of the instrument. Care should, however, be exercised during maintenance and the disposal of certain parts.

Repair and Maintenance

The instrument must be maintained or repaired either by the manufacturer or an accredited service agent. For Michell Instruments' contact information please go to www.ProcessSensing.com.

Calibration

The recommended calibration interval for this instrument is 12 months. The instrument should be returned to the manufacturer, Michell Instruments Ltd, or one of their accredited service agents, for re-calibration.

Safety Conformity

This product meets the essential protection requirements of the relevant UK, EU and US standards and directives. Further details of applied standards may be found in the Technical Specifications in Appendix A.

Abbreviations

The following abbreviations are used in this manual:

| | |
|--------|----------------------------------|
| bara | bar absolute |
| barg | bar gauge (100 kPa or 0.987 atm) |
| °C | degrees Celsius |
| °F | degrees Fahrenheit |
| ∅ | diameter |
| DC | direct current |
| fps | feet per second |
| g | grams |
| HTL | heat trace line |
| in | inch(es) |
| m/sec | meters per second |
| µm | micrometer |
| mA | milliampere |
| mm | millimetres |
| MPa | megapascal |
| NI/min | normal liters per minute |
| Nm | Newton meter |
| Ω | Ohms |
| oz | ounces |
| psia | absolute pressure |
| RH | relative humidity |
| scfh | standard cubic feet per hour |
| T | temperature |
| V | Volts |

Warnings

The general warnings listed below are applicable to this instrument. They are repeated in the text in the appropriate locations.



Where this hazard warning symbol appears in the following sections, it is used to indicate areas where potentially hazardous operations need to be carried out.



Where this symbol appears in the following sections it is used to indicate areas of potential risk of electric shock.



Where this symbol appears in the following sections, it is used to indicate surfaces that could be hot to touch.

1 Introduction

The S8000 HT is a high-precision laboratory reference instrument for the measurement of moisture content in air and other gases. Relative humidity and other calculated parameters based on dew point, pressure and temperature of the sample gas can also be displayed. Gases can be sampled at a maximum pressure of 0.5 barg (7.25 psig).

The S8000 HT is capable of measuring dew points as low as $-30\text{ }^{\circ}\text{C}$ ($-22\text{ }^{\circ}\text{F}$), up to a maximum of $+95\text{ }^{\circ}\text{C}$ ($+203\text{ }^{\circ}\text{F}$).

1.1. Operating Principle

The system operates on the chilled mirror principle, whereby the gas sample flows over the surface of a chilled copper gold-plated mirror and, at a temperature dependent on the moisture content and pressure of the gas, the moisture in the gas condenses out onto the surface of the mirror.

An optical system is used to detect the point at which this occurs, and this information is used to control the mirror temperature and maintain a constant thickness of the condensation layer on the mirror surface.

The above is achieved by a light-emitting diode providing a light source of constant intensity which is focused on the mirror surface to flood it with light.

A photo detector measures the light level reflected by the mirror and its output is then used to control the drive to a heat pump/thermo-electric cooler to maintain a constant level of condensation on the mirror surface.

At this point of equilibrium, where the evaporation and condensation rates on the surface of the mirror are equal, the mirror temperature is measured via a Pt100 platinum resistance thermometer (PRT) embedded in the mirror, which is recorded as the dew point.

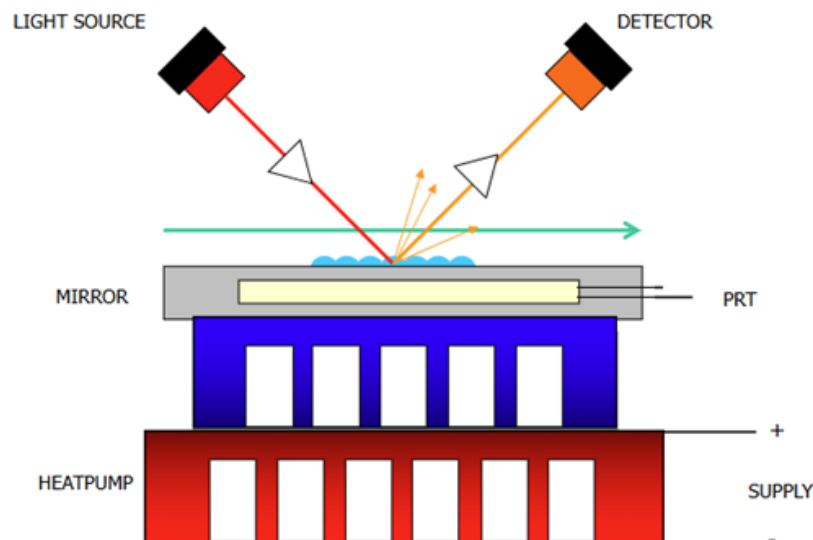

Figure 1 *Operating Principle*

2 Installation

2.1. Safety



It is essential that the installation of the electrical and gas supplies to this instrument be undertaken by competent personnel.

2.2. Unpacking the Instrument

The S8000 HT is a heavy instrument and should be unpacked by two people. Carefully open the crate and check for any signs of transit damage before touching the instrument. Remove the accessories before removing the instrument.

Carefully lift the unit out, holding the case and not the foam.

Ensure one person has a good grip of the unit whilst the other removes the foam protectors.

Save all the packing materials for the purpose of returning the instrument for re-calibration or any warranty claims.

Failure to return the instrument in the original packing may result in warranty claims being denied.

The accessories crate should contain the following items:

- Calibration certificate
- Pressure transmitter calibration certificate (optional)
- SD card
- USB communications cable
- IEC power cable
- Remote Pt100 temperature probe
- Optics cleaning kit
- Two heat trace lines (2M)
- Heat trace line insulation cover

If there are any shortages, please notify the supplier immediately.

2.3. Positioning

The right-hand side of the instrument can get hot during the initial cool down of the instrument, so ensure that there is at least 100 mm of free space between the instrument and any other object.

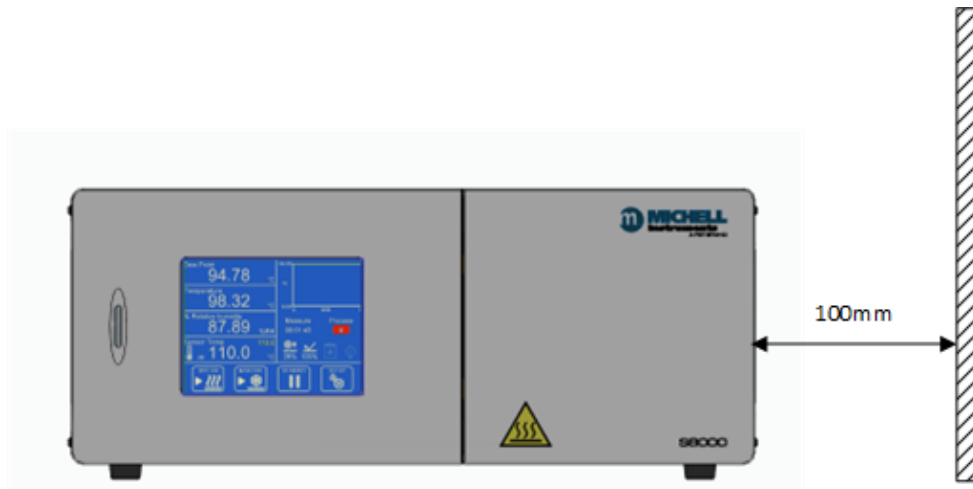

2.4. Connecting the Instrument

Connect the mains cable and ensure the instrument is positioned so that it can be easily switched on and off.

Pass the Heat Trace Lines (HTLs) through the insulated shield as shown below.



Connect the HTLs to the gas and electrical connectors as shown in Section 2.4.2.2 and described below:

- Connect the gas inlet HTL to gas coupling **2** and the electrical connector **11**.
- Connect the gas outlet HTL to gas coupling **1** for a flowing sample or **3** if the sample is to be drawn by the internal pump.
- Connect the gas outlet HTL electrical connector to **12**.
- Push the insulated shield along the HTLs until the magnet secures it to the rear panel.
- Position the other end of the gas inlet HTL into the side wall of the generator or chamber as shown below, whereby the 'rubber boot' should be the only section of the HTL that is exposed to the heated environment.

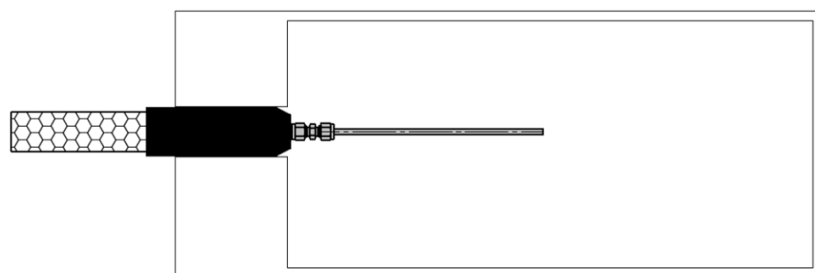

Connect the Remote Temperature Probe as shown in Section 2.4.6.

To use the outputs from the instrument:

- See Section 2.4.4 for details on the Analog Outputs.
- See Section 2.4.5 for details on the Alarm Output.
- See Section 2.4.7 for details on the USB communications.
- See Section 2.4.8 for details on the Ethernet and RS485 communications.

2.5. Operating Requirements

2.5.1. Environmental Requirements

It is important to operate the S8000 HT within the following environmental conditions:

| | |
|-------------------------------|-------|
| Minimum Operating Temperature | 10 °C |
| Maximum Operating Temperature | 35 °C |
| Maximum Relative Humidity | 95 % |

This instrument has been independently tested and evaluated in accordance with IEC 61010-1 and IEC 61010-2-010. Testing was carried out under the IEC CB Scheme, including all applicable national deviations. A CB Test Certificate is available on request.

This product is designed to be safe at least under the following conditions:

- Within a temperature range of +10 °C to +35 °C (+50 °F to +95 °F)
- In maximum 95 %rh
- Supply voltages of ± 10 % and transient over voltages up to Overvoltage Category II
- Pollution Degree 2
- Altitudes up to 2000 m
- Indoor use

See Appendix A, Technical Specification, for full operating parameters.

2.5.2. Electrical Requirements

The S8000 HT requires the following electrical supply:

- 100 to 240 Vac, 50/60 Hz, 580 VA max.
- Alarm outputs comprise two sets of changeover relay contacts, one set for a **PROCESS** alarm and one set for an **INSTRUMENT FAULT**. Both sets of contacts are rated at 30 V, 1A. **NOTE: This rating must not be exceeded.**

2.5.2.1. Front Panel

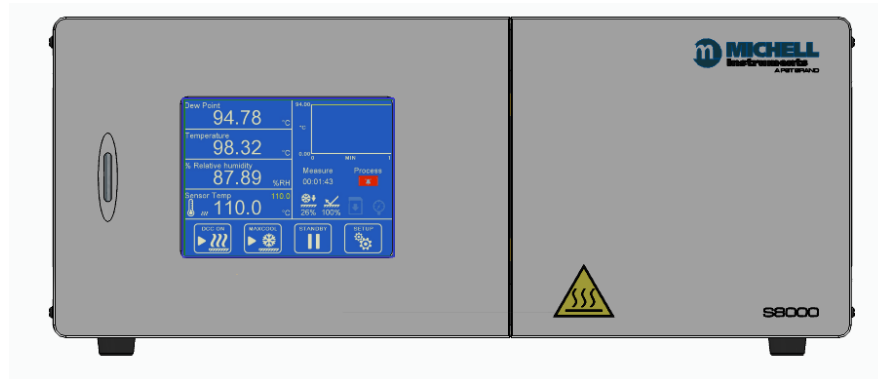

Figure 2 Front Panel

| No | Name | Description |
|----|---|--|
| 1 | SD Card Slot | Takes an SD card used to store logged data See Section 3.5.8 for more details on how to use the logging features |
| 2 | Touch Screen Display | Displays measured values and enables the user to control the operation of the instrument See Section 3.5 for information about the touch screen and menu system |
| 3 | Sensor Access Door | Access door to the dew-point sensor |
| |  | Ensure the sensor temperature is ≤ 30 °C before opening the door and handling the sensor for service and maintenance. |

Table 1 Front Panel Controls

2.5.2.2. Rear Panel Connections

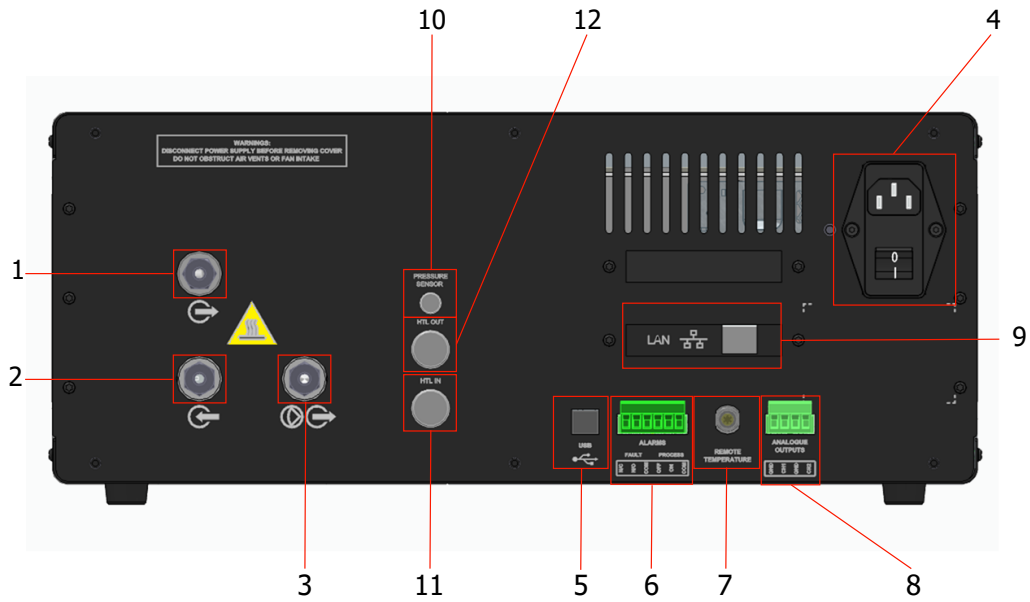





Figure 3 Rear Panel

| No | Name | Description |
|----|---|---|
| 1 | <p>¼ in Swagelok Gas Output</p>  | <p>Outlet connection for a pressurized sample gas (NON-PUMPED). The Outlet HTL needs to be coupled to this connection.</p> <p>Ensure the sensor temperature is <30 °C before handling</p> |
| 2 | <p>¼ in Swagelok Gas Inlet</p>  | <p>Connection for supplying the instrument with sample gas, usually at a pressure slightly higher than atmospheric to maintain flow through the instrument. The Inlet HTL needs to be coupled to this connection. For use with and without the pump.</p> <p>Ensure the sensor temperature is <30 °C before handling</p> |
| 3 | <p>¼ in Swagelok Gas Output</p>  | <p>Outlet connection for PUMPED sample gas. The Outlet HTL needs to be coupled to this connection.</p> <p>Ensure the sensor temperature is <30 °C before handling</p> |
| 4 | Mains power IEC Socket | <p>Universal power input 100 Vac to 240 Vac, 580 VA, 50/60 Hz Fuse – T6.3AH250V, Slow-acting, High breaking capacity, 6.3 A, Ceramic, 20 mm x 5 mm Features integrated power ON/OFF switch</p> |
| 5 | USB Type B socket | Used for communication with the instrument via the application software |
| 6 | 6-Way Alarm Relay Connector | <p>Process and Fault alarm outputs</p> <p>See Section 2.4.5 for general information on the alarm relays</p> <p>See Section 3.4.10 for instructions on how to configure the process alarm</p> |
| 7 | Remote Temperature Probe Connector | Connection for the remote Pt100 temperature probe |
| 8 | 4-Way Analog Output Connector | <p>Two configurable 2-wire channels providing 0 to 20 mA or 4 to 20 mA output. The outputs are active (sourcing) and must be connected to a passive (sinking) input on the receiving equipment.</p> <p>See Section 3.4.9 for instructions on how to configure the analog outputs.</p> |

| | | |
|----|---------------------------|--|
| 9 | Ethernet/RS485 (optional) | See Section 2.4.8 for connection details and Sections 3.4.14 and 3.4.15 for configuration details. |
| 10 | Pressure transmitter | Connection for an optional pressure transmitter |
| 11 | HTL-IN | Electrical connection for the inlet HTL |
| 12 | HTL-OUT | Electrical connection for the outlet HTL |

Table 2 *Rear Panel Connections*

These tasks should only be undertaken by competent personnel.



All the connections to the rear panel are electrical connections. Exercise due caution, particularly when connecting to external alarm circuits which could be at high potential.

Connections to the rear panel of the instrument are explained in the following sections.

2.5.3. Power Supply Input

The AC power supply is a push fit into the IEC C13 power input socket.



Ensure the power switch is OFF before connecting the cable.

The voltage range is 100 to 240 Vac, 50/60 Hz.

Ensure that any replacement power supply cables are adequately rated.

2.5.4. Analog Output Connections

The two analog outputs can be configured to represent any of the directly measured or calculated output parameters. They are provided as 2-wire signals from a 6-way connector located on the rear panel of the instrument.

Each of these outputs provide a current loop signal (4 to 20 mA or 0 to 20 mA). The 0/4 to 20 mA outputs are active (sourcing) and must be connected to a passive (sinking) input on the receiving equipment. The configuration of these outputs, i.e. parameter represented, output type (current loop or voltage) and upper/lower span levels are set up via the Setup Menu Screen (refer to Section 3.4.5).

These signals may be used to control external systems. During a **DCC** cycle, and for the hold period following a **DCC** cycle, they are held at the level that they were at immediately prior to the start of the cycle. When the dew-point measurement is stable, or if the maximum hold period has expired, they are released and will track the selected parameter throughout the measurement cycle.

The default settings of these analog outputs are:

Channel 1: Dew point, 0 to +100 °C

Channel 2: Temperature, 0 to 100 °C

NOTE: The analog outputs are only active during the MEASURE phase. They will, therefore, be off after switch-on and remain off until the system enters the MEASURE phase.

The two analog output port connections are made via a single 4-way push fit connector block. All outputs are 2-wire, positive-going signals referenced to a common 0 V line. To differentiate between the outputs it is recommended that a black lead be used for each of the COM (common) lines and a separate color for each of the positive lines.

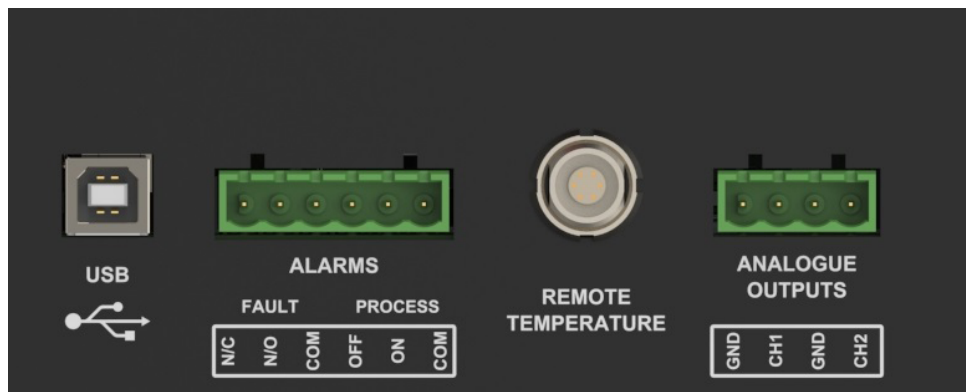

Figure 4 Alarm and Analog Output Connection

2.5.5. Alarm Output Connections

Two alarm outputs are provided from a terminal block, located on the rear panel of the instrument, as two pairs of potential free, change-over relay contacts. These are designated as a **PROCESS** alarm and a **FAULT** alarm.

Under the Setup Menu Screen, (refer to Section 3.4.5), the **PROCESS** alarm can be configured to represent any one of the measured or calculated parameters and set up to operate when a pre-set parameter threshold level is exceeded. By default, the **PROCESS** alarm is set to monitor the dew-point parameter.

The two alarm output ports are connected to the instrument via a single 6-way, push-fit connector block as shown in *Figure 5*. Each output comprises a 3-wire set of potential free, change-over relay contacts.

Each contact set is labelled **COM** (common 0 V), **N/O** (normally open with respect to **COM**) and **N/C** (normally closed with respect to **COM**).

To differentiate between the alarm output channels, it is recommended that a black lead is used for each of the **COM** (common) lines and a separate color for each of the **N/O** and **N/C** lines.



Alarm leads MUST be potential free when wiring to the connector block. Both sets of contacts are rated at 30 V, 1A. THIS RATING MUST NOT BE EXCEEDED.

2.5.6. Remote Temperature Probe

1. Align the red dot on the body of the temperature probe connector with the red dot on the socket labelled **REMOTE TEMPERATURE** (see *Figure 5*).
2. Push the connector into the socket until it locks. **NOTE: Do not attempt to force it into the socket. If it does not fit in, rotate it until the key locks and it pushes in easily.**
3. To remove the connector, slide the connector's body collar (1) back along its axis, away from the instrument, to release the lock. Gently pull the connector body out of the socket. **NOTE: Do not attempt to pull the connector out with the cable – make sure that the collar is released first.**

2.5.7. USB Communications Port Connector

The instrument features a USB port for communication with the application software. The appropriate cable will be supplied with the instrument.

1. Check the orientation of the connector and gently push it into the communications socket (see *Figures 5 and 6*).
2. To remove the connector, pull it out of the socket by holding the connector body. **Do not attempt to remove the connector from the socket by pulling on the cable.**

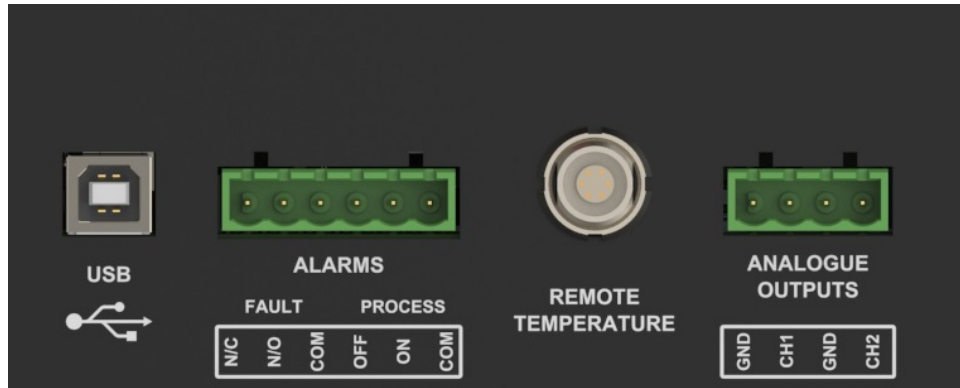

Figure 5 *USB Port Connection*

The application software includes a virtual serial port driver allowing the customers own software to be used with the device. The communications protocol used is Modbus RTU. Refer to Appendix B for the Modbus register map.

2.5.8. Ethernet/RS485 Port (optional)

The instrument features an optional additional digital communication point. If Ethernet is selected, then an RJ45 socket is present. The protocol used is Modbus TCP.



Figure 6 Ethernet Port

If RS485 is selected, a standard 9-pin D-sub connector is fitted. The communications protocol used is Modbus RTU. Refer to Appendix B for the Modbus register map.

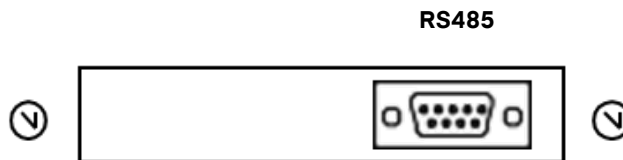
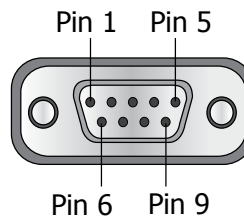

Figure 7 RS485 Port (optional)

RS485

| | |
|-------|-----|
| Pin 3 | A |
| Pin 5 | GND |
| Pin 8 | B |

RS485 Pinout (9-pin female)



3 OPERATION

As supplied, the S8000 HT is ready for operation and a set of default parameters has been installed. This section describes both the general operation of the instrument and the method of setting it up and changing the default parameters, should this become necessary.

3.1. General Operational Information

While the instrument can physically operate in a flowing gas stream of between 500 mL/min and 1000 mL/min (1 scfh and 2.1 scfh), Michell Instruments recommends operating at 750 mL/min (1.6 scfh), which is the flow rate used during calibration. Operating at an alternative rate could impact the instrument's response time.

The sample inside the sensor is passed over a Peltier chilled, gold-plated mirror. The instrument controls the mirror temperature to a point where a level of condensate is maintained on the mirror surface. The temperature of the mirror is then measured as the dew point.

The S8000 HT is suitable for the measurement of moisture content in a wide variety of clean, non-corrosive gases. It will not contaminate high-purity gases and is safe for use in critical semiconductor and fiber optic manufacturing applications.

3.1.1. Sample Flow Adjustment

- The sample flow is measured by the internal flow meter installed into the sample line.
- The recommended flow setting is 750 mL/min (1.6 scfh).
- The sample flow can be adjusted by the installation of a valve in the sample line. Ideally the valve should be installed downstream of the sensor to avoid any influence of moisture ingress on the readings; however, in this configuration care needs to be taken to ensure the flow rates in the system are balanced, otherwise differences in pressure are possible between the hygrometers in the system.
- If the flow control valve needs to be installed upstream of the sensor, a bellows-type valve should be used.

3.2. Operational Functions

3.2.1. Operating Cycle

The default parameters set up for the instrument define an operating cycle, see *Figure 8*.

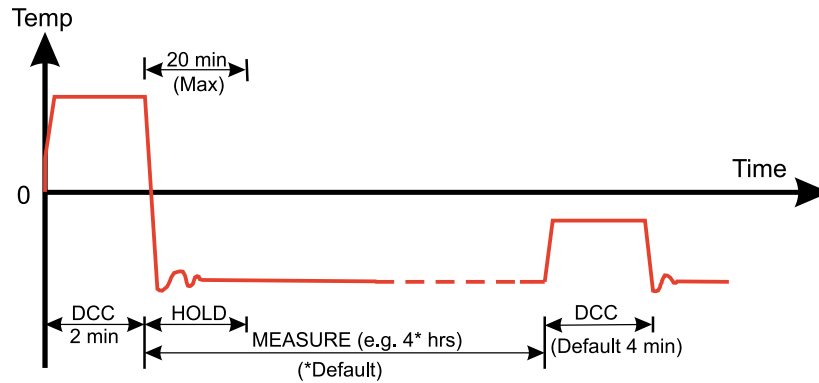

Figure 8 *Typical Operating Cycle*

At initial switch-on, the instrument enters a DCC cycle for 2 minutes. By default, this heats the mirror 20 °C (36 °F) above the previously measured value – at the time of switch-on, this will be ambient temperature. This ensures that all moisture is driven off the surface of the mirror.

The mirror is maintained at this temperature for the DCC duration (default 4 minutes) or 2 minutes on switch-on. During the DCC process, Data Hold fixes the analog outputs at the value(s) read before DCC commenced. Data Hold typically lasts 4 minutes from the end of a DCC cycle, or until the instrument has reached the dew point. This procedure is in place to prevent any system which is connected to the outputs from receiving a 'false' reading.

After the DCC period has finished, the measurement (**MEASURE**) period commences, during which the control system decreases the mirror temperature until it reaches the dew point. The sensor will take a short amount of time to settle on the dew point. The length of this stabilization time depends upon the temperature of the dew point. When the measurement is stable, the Sensor area of the display will indicate **CONTROL**.

If the sensor cooler is in automatic mode, the set point will automatically be adjusted if the dew point is determined to be outside of the mirror's current measurement range.

The end of a DCC cycle re-sets the interval counter, meaning that another DCC will start (by default) in 4 hours' time. Once the measurement is stable, **HOLD** will release and the analog outputs will resume their normal operation. At this point, the **STATUS** area of the display will change to **MEASURE**.

3.3. Operating Guide

3.3.1. Remote Temperature Probe

Insert the temperature probe into the Generator/Chamber/System to measure the temperature of the environment, which, by definition, will be the absolute maximum dew point that can be produced by the system, and measured.

3.3.2. Sensor Temperature and HTL Control

When the instrument is switched on, the cooler set-point will initially be +25 °C (+77 °F). The instrument will initialize by running a DCC cycle. After the DCC cycle is complete, the system will cool the mirror. As soon as moisture is detected on the mirror, the instrument will calculate the required sensor temperature set-point, which will be displayed in yellow in the top right of the sensor temperature readout on the Main Screen.

If the measured dew point is +13 °C (+55.4 °F) or below, the temperature of the sensor and HTLs will remain at +25 °C (+77 °F); however, if the dew point is above that, the system will increase the temperature sensor & HTLs by +20 °C (+68 °F). The reason for this is the automatic flood prevention algorithm that ensures the system will not flood when used in normal conditions. This function will operate up to the maximum measurement range of +95 °Cdp (+203 °F), whereby the system will set a maximum sensor and HTL temperature of +110 °C (+230 °F).

The flood prevention system only operates with an increasing dew point measurement and not when the measured dew point is decreasing. Therefore if, for example the measured dew point decreases by more than +40 °C (+104 °F) from its previous measurement, then the sensor temperature should be reduced manually by +20 °C (+68 °F).

3.3.2.1. Operating Practice

As mentioned in Section 3.3.1 above, the sensor and heat trace line temperatures need to be at least 20 °C (68 °F) above the dew point to ensure that condensation doesn't form within the sensor oven components – i.e., the sensor, tubing, flow transmitter and pump. The temperature stabilization time for the sensor oven is approximately 1.5 hours; therefore, to measure a dew point above the ambient temperature, and especially at %rh levels above 80 %, you need to allow for the stabilization time.

Measurement Procedure

- Set the sensor temperature to at least 20 °C (36 °F) above the maximum dew point to be measured or that can possibly occur within the system. This temperature will be that measured by the Remote Temperature Probe. Do this before setting the temperature of the Generator/Chamber/System.
- Wait for the sensor temperature to stabilize; allow at least 1.5 hours for the temperature to become uniform, especially when the dew point to be measured is above 60 °C (140 °F).
- Ensure the HTL temperatures are within ± 1 °C (± 0.18 °F) of the sensor temperature set point. Press the sensor temperature value to view the Sensor/HTL setup page shown below.

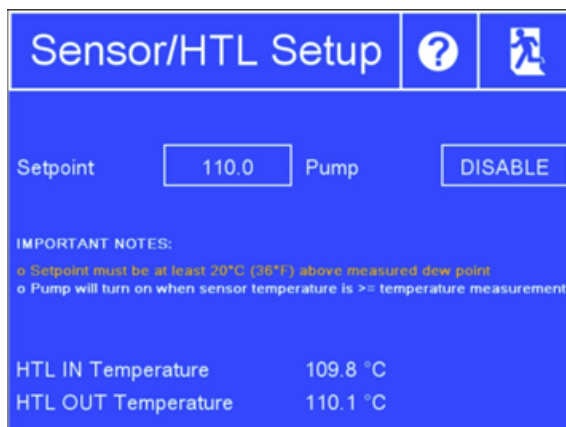

3.3.3. Shutdown Procedure

To prevent damage to the instrument, follow this procedure each time the unit needs to be powered off:

1. Set the dew point of the Chamber/Generator/System to $\leq +10$ °Cdp (+50 °Fdp)..
2. Wait until the dew point measured by the sensor is $\leq +10$ °Cdp (+50 °Fdp).
3. Set the sensor to Standby.
4. Set the sensor temperature to +25 °C (+77 °F).
5. The power to the instrument can then be turned off.

3.3.4. DCC – Dynamic Contamination Control

Dynamic Contamination Control (**DCC**) is a system designed to compensate for the loss of measurement accuracy which results from mirror surface contamination.

During the **DCC** process, the mirror is heated to a default temperature of 20 °C (36 °F) above the dew point to remove the contamination that has formed during measurement. The surface finish of this mirror, with the contamination which remains, is used by the optics as a reference point for further measurements. This removes the effect of contamination on accuracy.

After switch-on, the mirror is assumed to be clean, therefore the instrument will only run a **DCC** for 2 minutes to quickly establish a clean mirror reference point. By default, every subsequent **DCC** is 4 minutes in duration and will automatically occur every 4 hours.

At certain times, it may be desirable to disable the **DCC** function in order to prevent it from interrupting a measurement cycle, e.g. during a calibration run.

A manual **DCC** can be initiated or cancelled by touching the **DCC** button on the Main Screen. The **DCC** button is context sensitive, i.e. if **DCC** is on, the Main Screen shows **DCC OFF** as being selectable. Similarly, if **DCC** is off, **DCC ON** is shown.

It is possible to change the parameters relating to the **DCC** cycle on the **DCC** Setup Screen; refer to Section 3.4.7.

3.3.5. MAXCOOL Function

The **MAXCOOL** function overrides the dew-point control loop and applies maximum cooling drive to the Peltier heat pump. It can be used:

- to determine what temperature the mirror can be driven down to with reference to the sensor body. This temperature is indicated on the display.
- to determine whether or not the instrument is controlling at the dew point and whether it is able to reach it. This situation could, for instance, arise when attempting to measure very low dew points where, possibly due to a high ambient temperature, the Peltier heat pump is unable to depress the temperature far enough to reach the dew point.
- to determine whether the instrument is controlling by switching **MAXCOOL** on for a short period and then switching back to **MEASURE**. This will depress the mirror temperature briefly and when it is switched back to **MEASURE**, the control loop should be able to stabilize the mirror temperature at the dew point again.

The **MAXCOOL** function can be turned on by touching the **MAXCOOL** button on the Main Screen.

3.3.6. Pressure Transmitter Input

The S8000 HT has the option to measure the atmospheric pressure of the environment to compensate for parameters that are reliant upon pressure i.e. ppm_v, ppm_w, g/m³ and g/kg. The optional 4 mA to 20 mA pressure transducer has a range of 0 barg to 0.6 barg (0 psig to 8.7 psig) with a 1/8th NPT gas coupling.

3.3.7. Data Logging

The data logging function allows all of the measured parameters to be logged at a user-specified interval on the supplied SD card via the SD card slot on the front of the instrument. The filename for each log file is generated automatically from the instrument date and time.

Log files are saved in CSV (comma separated value) format. This allows them to be imported easily into Excel or other programs for charting and trend analysis. To set up data logging, refer to Section 3.4.8.

3.3.8. Frost Assurance Technology (FAST)

Theoretically, it is possible for water to exist as a super-cooled liquid at temperatures down to -40 °C (-40 °F).

A gas in equilibrium with ice is capable of supporting a greater quantity of water vapor at a given temperature than a gas in equilibrium with liquid water. This means that a measurement below 0 °C (+32 °F) taken over water will read approximately 10 % lower than the same measurement taken over ice.

When turned on and **FAST** is enabled, the S8000 HT makes an initial dew-point measurement. If the initial measurement is between 0 °C and -30 °C (+32 °F and -22 °F) then the mirror is driven down to below -35 °C (-31 °F) to ensure the formation of ice on the mirror surface. The instrument then continues operation as normal – once ice has formed it will remain as ice until the temperature is raised above 0 °C (+32 °F).

If required, the instrument's **FAST** function can be switched on and off.

3.3.9. STANDBY Mode

In **STANDBY** mode, drive to the Thermo-electric cooler is removed and the displayed dew-point value will increase and settle at a temperature within a few degrees of the sensor temperature.

The main use for this feature is to allow the instrument to purge and set the sensor temperature before beginning a measurement.

Alternatively, it may be used in applications requiring infrequent manual measurements to be taken, where it is preferable to have the sensor disabled between measurements.

3.4. User Interface

The S8000 HT features a 5.7" color touch-screen display.

When the instrument is switched on, an **Initializing** overlay will be shown while the menu system loads.

After the menu system has loaded, the Main Screen will show.

3.4.1. Main Screen

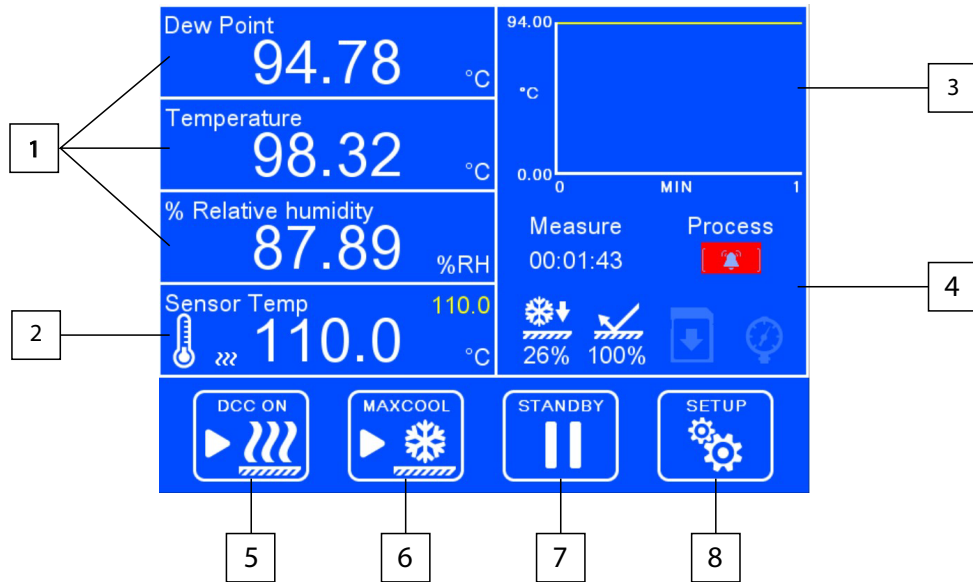

Figure 9 Main Screen

| No | Name | Description |
|----|----------------------------|--|
| 1 | Readouts (Customizable) | Display measured and calculated parameters. See Section 3.4.2 for additional information. |
| 2 | Sensor Temperature Readout | The main figure in this display is the measured sensor body temperature. The temperature set-point is displayed in yellow in the top right of the readout. Touch the readout once to display the Sensor/HTL setup menu and refer to Section 3.4.4 for details. |
| 3 | Stability Graph | Plots measured dew point over time. Time base can be changed in display settings. Touch the readout once to enter full-screen mode. |
| 4 | Operational Status Display | A detailed description of each item displayed in this area is in Section 3.4.3. |
| 5 | DCC Button | Initiates or cancels a DCC. See Section 3.3.3 for a detailed explanation of the DCC function. See Section 3.4.7 for DCC setup parameters. |
| 6 | MAXCOOL Button | Initiates or cancels MAXCOOL mode. See Section 3.3.4 for a detailed explanation of the MAXCOOL function. |
| 7 | Measure/STANDBY Button | Toggles between Measure and Standby mode. See Section 3.3.8 for a detailed explanation of standby mode. |
| 8 | SETUP Button | Access the Setup Menu. See Section 3.4.6 for information on the menu structure and options. |

Table 3 Main Screen Description

3.4.2. Customizable Readouts

The three readouts on the Main Screen can be configured by the user to show any of the following parameters:

- Dew Point
- Temperature
- Pressure
- % Relative Humidity
- g/m³
- g/kg
- ppm_v
- %Vol
- Twb
- wvp (water vapor pressure)
- Dew Point (pressure corrected)

The parameters displayed by default are Dew point, Pressure and Flow.

Follow these instructions to change the parameter:

1. Touch the readout once to enable parameter selection.
2. Touch the left or right arrows to select the parameter to be displayed.
3. Touch the center of the readout to confirm selection.

3.4.2.1. Full-Screen Mode

Any of the readouts can be shown in full-screen mode by touching and holding the readout.

3.4.3. Operational Status Display

The Operational Status display includes the following:





| | |
|---|---|
| <p>Mode</p> | <p>Reports current operational mode. This will either be Measure, Standby, DCC, Hold, Maxcool or Flood.</p> |
| <p>Next Mode</p> | <p>Shows the time (in Hours: Minutes: Seconds) remaining until the transition to the next mode of operation. If DCC is configured for manual activation only, then this countdown will display --:--:--.</p> |
| <p>Process</p> | <p>This notification indicates whether a parameter process alarm is either ON or OFF. The process alarm can be set on any parameter (refer to Section 3.4.10).</p> |
| <p>Film Thickness</p>  | <p>This figure indicates the quantity of condensate present on the mirror on a % scale. 0 % indicates condensate has not yet formed. 100 % is the target level, and ± 1 % indicates the instrument is stable and controlling on the dew/frost point.</p> |
| <p>TEC Drive</p>   | <p>This symbol changes to indicate that the mirror is either being heated or cooled. The figure indicates the % of the total available cooling or heating power currently being used.</p> |
| <p>Logging</p>  | <p>Indicates data logging to SD is enabled. Refer to Section 3.4.8.</p> |
| <p>Pressure compensation</p>  | <p>Indicates dew point is being calculated to atmospheric pressure. Refer to Section 3.4.13.</p> |

Table 4 Operational Status Display

3.4.4. Sensor/HTL Setup

The Sensor/HTL (Heat Trace Line) Setup window is accessed by touching the Sensor Temp readout on the Main Screen. The temperature of the sensor and both HTLs are set by pressing the Setpoint value (40 °C in this example) and by entering the temperature via the keypad.

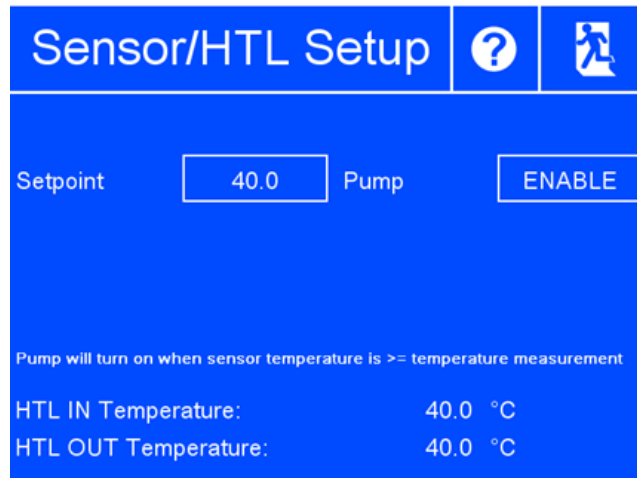

Figure 10 *Sensor/HTL Setup Screen*

This window also displays the live temperatures of the HTLs as shown at the bottom of the window.

In addition, the pump can be enabled (turned on) or disabled (turned off) by pressing ENABLE/DISABLE. In this example, the pump is OFF and will turn ON when 'ENABLE' is pressed. It should be noted that the pump will only turn on if enabled and when the temperature of the sensor is < the temperature of the environment that is being measured – i.e., the temperature measurement.

| Parameter | Description |
|-----------|--|
| Set-point | Used to set the temperature of the sensor over the range +25 to +110 °C (+77 to +230 °F) |
| Pump | Turns the Pump on and OFF |

Table 5 *Sensor/HTL Setup Parameters*

3.4.5. Setup Menu Screen

The Setup Menu is used to adjust the operational parameters of the instrument, change the display setup and start or stop the data-logging feature.

Initially, when the Setup Menu Screen is opened, a set of labelled icons is displayed. Touching one of these icons will take you to the appropriate submenu.

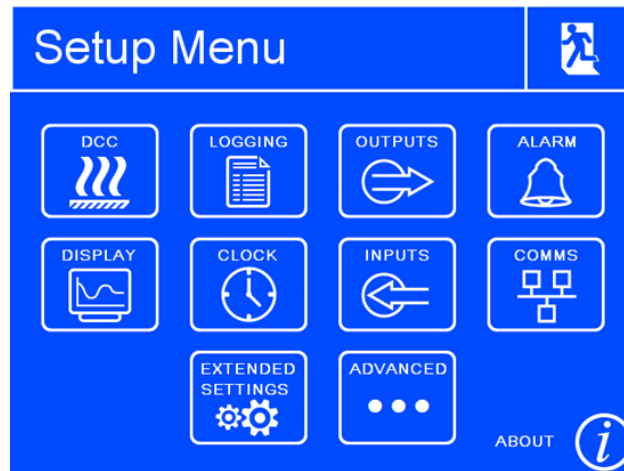

Figure 11 Setup Menu Screen

Once a submenu has been entered, parameters can be changed by touching the outlined values. There are three types of input for editable values:

- Toggle Button – Touching the outlined value will switch between predefined states, i.e. On/Off or Auto/manual.
- List Selection – A list of options will be displayed for the user to select.
- Numeric Input – Touching the outlined value will bring up the numeric keypad (see following page).

3.4.5.1 Numeric Input





When entering a numeric value, a virtual keypad will be displayed.



Figure 12 Virtual Keyboard

The allowable range will initially be shown at the top of the keypad, e.g. 0 → 50

Some parameters can be disabled by entering a value of 0; this will be indicated by 0[off] → 50

-  Clear Input
-  Backspace
-  Cancel input
-  Save input

3.4.5.2 Leaving Menus

 To return from a menu or to cancel a numeric input, touch the exit icon.

3.4.6. Menu Structure



| DCC | LOGGING | OUTPUTS | ALARM | DISPLAY | CLOCK | INPUTS | COMMS | EXTENDED SETTINGS |
|-------------|----------|---------------|-----------------------|---------------|-------|--------------------------|-----------------|-------------------|
| Type | Interval | Output Select | Type | Resolution | Date | Temperature input source | Modbus | PRT Mode |
| Setpoint | | Output Type | Parameter | Min Span | Time | Value | Address | Flood Recovery |
| Mode | | Parameter | Setpoint | Temp Unit | | Pressure Compensation | IP Address | |
| Interval | | Alarm | Hysteresis | Display Hold | | | Subnet Mask | |
| Period | | Minimum | Low Setpoint | Pressure Unit | | | Default Gateway | |
| Output Hold | | Maximum | High Setpoint | Timebase | | | | |
| FAST | | | Contamination Warning | Brightness | | | | |
| FAST SP | | | Calibrate Optics | | | | | |

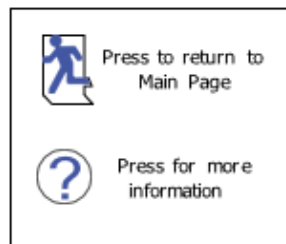

Figure 13 Menu Structure

3.4.7. DCC

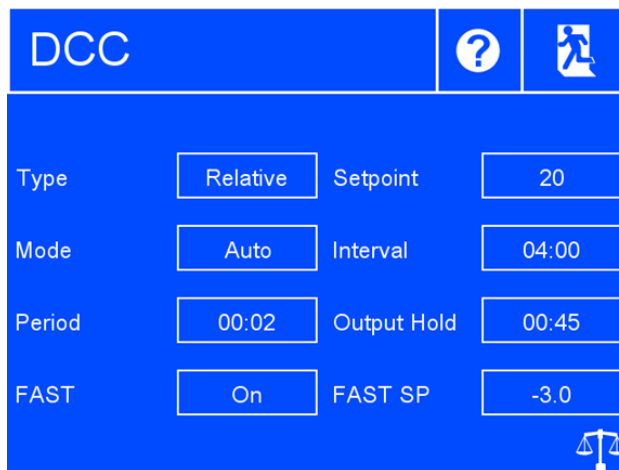

Figure 14 DCC Screen

| Parameter | Description |
|-------------|--|
| Type | DCC heating temperature can either be relative to last measured dew point or an absolute temperature. Actual temperature or Δ is defined by 'Setpoint'. Available Input: Relative, Absolute |
| Setpoint | Mirror heating temperature during DCC, either absolute or relative to last measured dew point. See 'Type' option above. Available Input: 1 to 120 °C |
| Mode | DCCs can either be triggered automatically at every interval or they can be manually triggered only. Available Input: Manual, Auto |
| Interval | Time between automatic DCCs Input format: hh:mm Limits: 00:30 to 99:00 |
| Period | Duration of the DCC Input format: hh:mm Limits: 00:01 to 00:10 |
| Output Hold | Minimum time to hold analog outputs after finishing a DCC Input format: hh:mm Limits: 00:20 to 01:00 |
| FAST | Turns frost assurance on or off. See Section 3.3.7 for further information Available Input: On, Off |
| FAST SP | Passing this mirror temperature will trigger the frost assurance function without a DCC Available Input: -22 to -2 °C |

Table 6 DCC Parameters

3.4.8. LOGGING

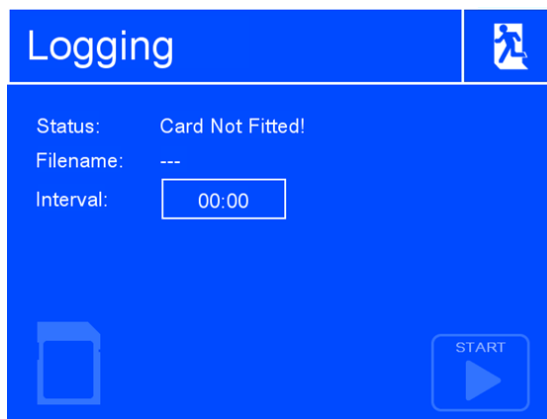

Figure 15 Logging Screen







| Parameter | Description | |
|---------------------|---|----------------------------|
| Interval | Changes the interval at which data is recorded Input format: mm:ss – Limits: 00:05 to 10:00 | |
| SD status indicator | Indicates status of inserted SD card: | |
| |  | No SD Card inserted |
| |  | Ready to log |
| |  | Initializing card |
| |  | Error occurred |
| |  | SD Card is write protected |
| |  | Logging |
| START/STOP | Begins a new log (file name is generated automatically) or ends a log in progress. | |

Table 7 Logging Parameters

3.4.9. OUTPUTS

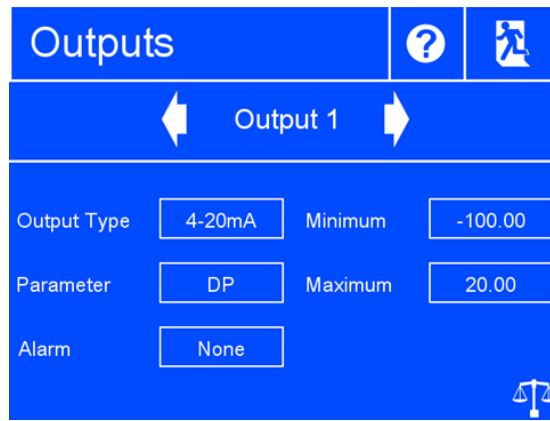

Figure 16 *Outputs Screen*

| Parameter | Description |
|------------------------|---|
| Output Selector Arrows | Selects the output to be adjusted |
| Output Type | Determines the mA output range Available Input: 4 to 20 mA/0 to 20 mA/0 to 1 V |
| Parameter | Assigns the chosen calculated or measured parameter to this output channel Available Input: Dew Point (DP), Temperature, Pressure, % Relative Humidity (%rh), g/m ³ , g/kg, ppm _v , %Vol, Wetbulb (Twb), wvp (water vapor pressure), Flow, ppm _w |
| Minimum | The minimum output range for the selected parameter Available Input: Dependent on parameter |
| Maximum | The maximum output range for the selected parameter Available Input: Dependent on parameter |
| Alarm | Available Options: None, System, Process, Both |

Table 8 *Outputs Parameters*

3.4.10. ALARM

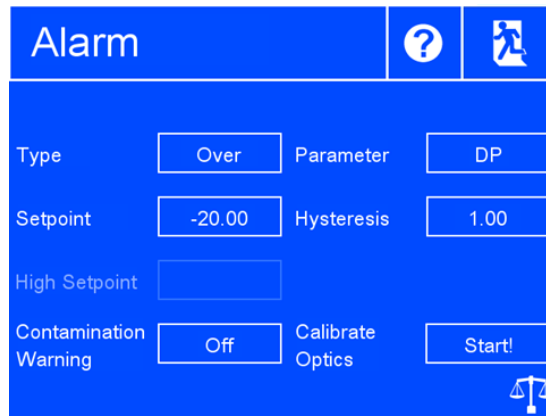

Figure 17 Alarm Screen

| Parameter | Description |
|-----------------------|--|
| Type | Sets the trip criteria for the process alarm. Available Input: Over, Under, In. Band, Out. Band, Off |
| Parameter | Sets the parameter associated with the process alarm. Available Input: Dew Point (DP), Temperature, Pressure, % Relative Humidity (%rh), g/m ³ , g/kg, ppm _v , %Vol, Wetbulb (Twb), wvp (water vapor pressure), Flow, ppm _w |
| Setpoint | Sets the trip point for Over or Under alarm types. Available Input: Dependent on parameter |
| Low Setpoint | Sets the low trip point for Band alarm types. Available Input: Dependent on parameter |
| High Setpoint | Sets the high trip point for Band alarm types. Available Input: Dependent on parameter |
| Hysteresis | Sets the deviation from trip point before the alarm deactivates. Available Input: Dependent on parameter |
| Contamination Warning | Sets whether an Optics Warning trips the process alarm. Refer to Section 4.2 for information about the optics warning. Available Input: On, Off |
| Calibrate Optics | It is necessary to run this function whenever the mirror is cleaned, or if a different dew-point sensor is installed. Following this, a DCC will begin. |

Table 9 Alarm Parameters

3.4.11. DISPLAY

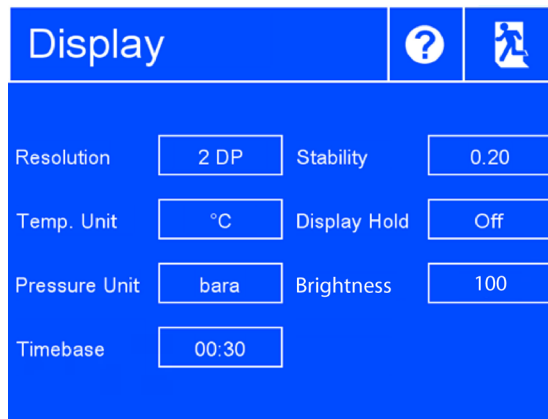

Figure 18 *Display Screen*

| Parameter | Description |
|------------------|---|
| Resolution | Changes the number of decimal places for all displayed parameters. Available Input: 1 DP, 2 DP, 3 DP |
| Temperature Unit | Measurement unit for temperature values Available Input: °C, °F |
| Pressure Unit | Measurement unit for pressure values Available Input: kPa, psig, psia, barg, bara |
| Timebase | X axis span for trend graph on main screen Input Format: hh:mm Limits: 00:01 to 10:00 |
| Min Span | Determines a stable measurement following DCC, which is conditional to release Data Hold. Entered value is Δ DP over 30s. Available Input: 1.0 to 20 |
| Display Hold | When enabled, values on display are also held during Data Hold. Available Input: Off, On |
| Brightness | Display backlight control Available Input: 5 to 100 % |

Table 10 *Display Parameters*

3.4.12. CLOCK



Figure 19 Clock Screen

| Parameter | Description |
|-----------|--------------|
| Date | Current date |
| Time | Current time |

Table 11 Clock Parameters

3.4.13. Inputs

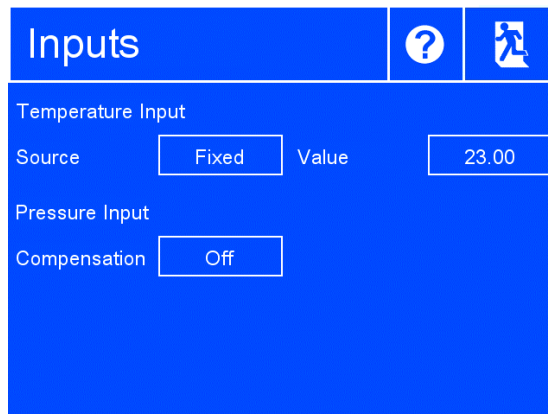

Figure 20 Inputs Screen

| Parameter | Description |
|-----------------------------|--|
| Source (Temperature Input) | Changes between temperature input from external Pt100 or a fixed value. Available Input: Fixed, External |
| Value (If 'Fixed' selected) | Sets temperature used for internal calculations. |
| Compensation | Recalculate dew point to atmospheric pressure based on measured pressure. Available Input: Off, On |

Table 12 Inputs Parameters

3.4.14. Comms

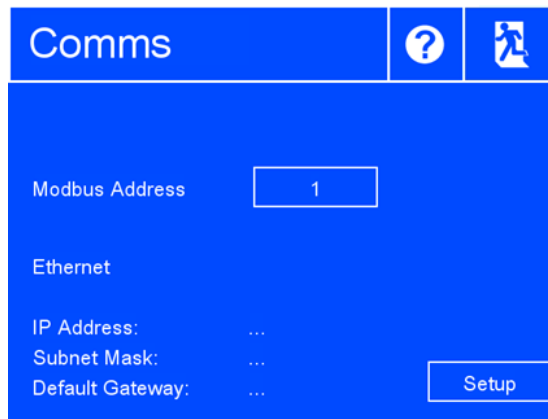

Figure 21 Comms Screen

| Parameter | Description |
|----------------|---|
| Modbus Address | Sets the Modbus slave address |
| Setup | Access the TCP/IP Network Settings page |

Table 13 Comms Parameters

3.4.15. Network Settings

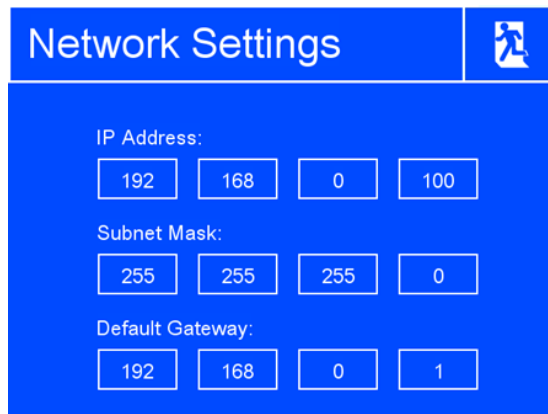

Figure 22 Network Settings Screen

| Parameter | Description |
|-----------------|-----------------------------------|
| IP Address | The IP address of the instrument |
| Subnet Mask | Determines network subnet address |
| Default Gateway | Default gateway address |

Table 14 Network Parameters

3.4.16. Extended Settings

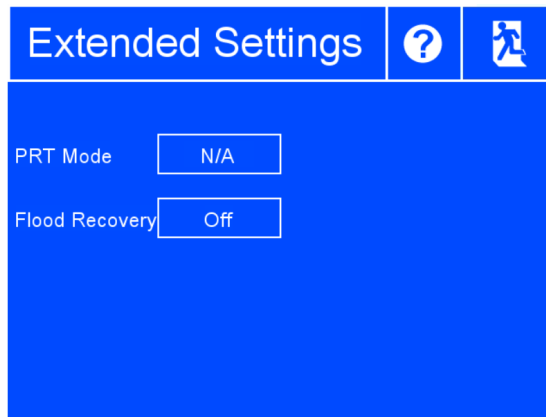

Figure 23 *Extended Settings Screen*

| Parameter | Description |
|----------------|---|
| PRT Mode | Option not available on this model |
| Flood Recovery | Sets sensor temperature to +20 °C and initiates an extended DCC if mirror temperature exceeds sensor temperature. See section 3.3.1.3 for further information. Available Input: Off, On |

Table 15 *Extended Settings Parameters*

4 Warnings and Faults

The S8000 HT contains a comprehensive self-diagnosis system to alert the user whenever there is an issue which could affect the measurement. These alerts are divided into two categories:

Warnings: A problem which is not currently affecting the measurement but requires attention.

Faults: A problem which requires immediate attention. Whenever a fault is triggered, the S8000 HT will switch to 'Standby' and remain in this mode until the operator intervenes.

When a Fault is present, the System Alarm symbol will appear over the sensor status display on the main screen. Pressing the System Alarm symbol will display all current faults and warnings. At any other time, active warnings can be viewed by pressing the right-hand side of the sensor status display. A system fault will usually be accompanied by one or more warnings, which describe the problem in more detail.

Once a fault has been resolved, it is necessary to run a DCC cycle to return the instrument to normal operation.

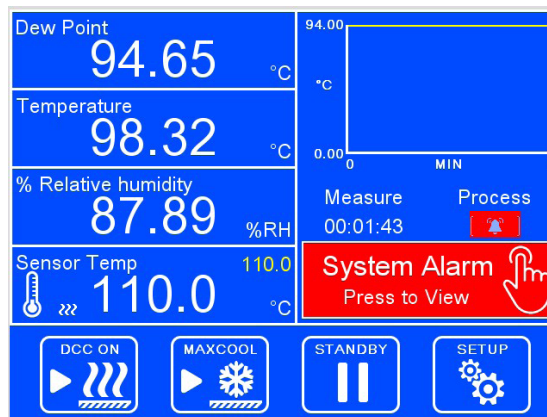

Figure 24 System Alarm Screen

4.1. Fault Codes

| No | Name | Description |
|----|-------------------------------------|---|
| 1 | Mirror PRT Failure | Chilled Mirror sensor Pt100 resistance out of range |
| 2 | Ambient PRT Failure | Remote Temperature probe Pt100 resistance out of range |
| 3 | Chiller PRT Failure | Cold finger Pt100 resistance out of range |
| 4 | RESERVED | |
| 5 | Mirror temperature too high | Mirror temperature exceeded 130 °C |
| 6 | Stirling emergency error | Sensor Cooler control PCB emergency alarm |
| 7 | Optics setpoint search failed | Optics calibration failed during DCC |
| 8 | Optics outside max. operating limit | Optics reflected signal out of range (high) |
| 9 | Optics outside min. operating limit | Optics reflected signal out of range (low) |
| 10 | Cooling Saturated timeout | TEC drive in maximum cooling mode beyond allowable time limit |
| 11 | Heating Saturated timeout | TEC drive in maximum heating mode beyond allowable time limit |
| 12 | RESERVED | |
| 13 | Pressure input failure | Pressure transmitter signal <3.6mA or >21 mA |
| 14 | Optics contamination | Mirror requires cleaning followed by Optics Calibration |
| 15 | Sensor over temperature | Cold finger temperature exceeded 50 °C for >30s. |

Optics Warning

Throughout the life of the instrument, periodic cleaning of the mirror surface and optics window will be required. The frequency of this depends upon operating conditions and the potential in the application for contaminants to be deposited on the mirror.

The S8000 HT will notify the user on the state of mirror contamination. The instrument will initially give a warning in the sensor status display when contamination is detected but will continue to operate. Cleaning the mirror then pressing the **Calibrate Optics** button is necessary when this warning is displayed. If the contamination reaches levels which will drastically affect performance, a fault alarm will trip, causing the instrument to switch to standby mode until action is taken.

For remote indication of an optics warning, the process alarm contact can be set to trip whenever the optics warning is active. See Section 3.4.10 for further information.

See Section 5.1 for mirror cleaning instructions.

5 Maintenance

5.1. Sensor Mirror Cleaning

Throughout the life of the instrument, periodic cleaning of the mirror surface and optics window may be required. The frequency of this depends upon operating conditions and the potential in the application for contaminants to be deposited on the mirror. Sensor cleaning is mandatory if the instrument indicates an optics fault.

1. Ensure the instrument is in Standby mode and the sensor temperature is at ambient temperature i.e. $<+30\text{ }^{\circ}\text{C}$ ($+86\text{ }^{\circ}\text{F}$).

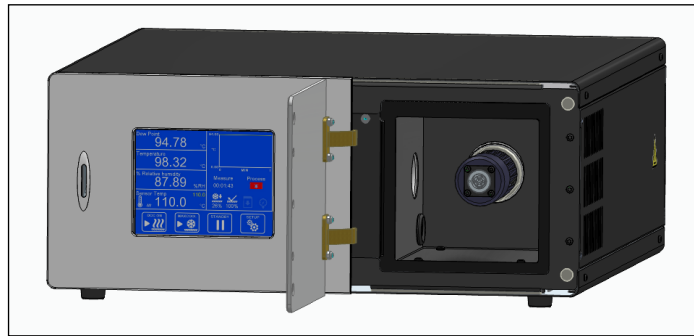

2. Open the sensor door and unscrew the sensor from the internal sample block.
3. Clean the mirror surface and optics window with a cotton bud/Q-Tip soaked in distilled water. If the sensor has been exposed to oil-based contamination, use one of the following solvents: methanol, ethanol, or isopropyl alcohol. To avoid damage to the mirror surface do not press too firmly on the cotton bud/Q-Tip when cleaning. Allow the cleaning solvent to fully evaporate and then clean with distilled water.

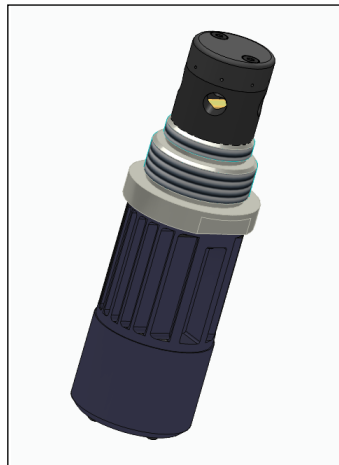

5.2. Fuse Replacement

If the instrument fails to operate after it has been connected to an AC power supply (100 Vac to 240 Vac, 50/60 Hz) and switched on, check:

- The fuse in the main plug (13 A).
- The fuse in the fuse holder shown below (T6.3AH250V, Slow-acting, High breaking capacity, 6.3 A, Ceramic, 20 mm x 5 mm). To replace this fuse, remove the mains lead and use a flat-blade screwdriver to prize out the fuse holder (shown below) via the slot in the top.

Fuse holder



6 Application Software

Application software which can be used for remote monitoring and data logging is available at ProcessSensing.com. A help file is included within the software for guidance on operation.

Appendix A

Technical Specifications

Appendix A Technical Specifications

| Dew-Point Sensor | |
|-----------------------------------|--|
| Measurement Range | -30 °C to +95 °C (-22 °F to +203 °F) frost/dew point |
| Measurement Accuracy* | ±0.1 °C (±0.18 °F) |
| Reproducibility | ±0.05 °Cdp (±0.09 °Fdp) |
| Stability | ±0.05 °C (±0.09 °F) |
| Mirror | Gold-plated copper |
| Temperature Measurement | 4-wire Pt100, 1/10 DIN class B |
| Sample Flow Rate | 250 mL/min to 1000 mL/min (recommended 750 mL/min) |
| Sample Gas Pressure | 0.5 barg (7.25 psig) max |
| Remote PRT | |
| Temperature Measurement | 4-wire Pt100, 1/10 DIN class B |
| Accuracy | ±0.1 °C (±0.18 °F) |
| Cable Length | 2 m (6.6 ft) (250 m (820 ft) max) |
| Pressure Sensor (optional) | |
| Measurement Range | 0 barg to 0.6 barg (0 psig to 8.7 psig) |
| Measurement Accuracy | Accuracy ≤ ±1 % FS Thermal error ≤ 1.5 % FS Temp Comp 0 °C to +80 °C (-32 °F to +176 °F) |
| Flow Sensor | |
| Measurement Range | 0 mL/min to 5000 mL/min |
| Measurement Accuracy | ±1.5 % FS (10 % to 100 % of rated flow) |
| Monitor | |
| Resolution | User selectable to 0.001 °C (0.0018 °F), depending on parameter |
| Measurement Units | °C dew/frost point, °C temperature, mL/min flow, bara pressure |
| Calculated Units | Relative humidity – %, Absolute humidity – g/m ³ , ppm _v , Mixing Ratio – g/kg, Wet Bulb Temperature (Twb) – °C, °F, Water Vapor Pressure (wvp) – Pa, °F, Pressure converted DP – °C, °F, Pressure – kPa, Bara, Barg, Psia, Psig |
| Outputs | Analog: 2 x active mA outputs, configurable 0 mA to 20 mA or 4 mA to 20 mA Digital: Modbus RTU over USB and Modbus TCP/IP over Ethernet or RS485 Alarm: 1x Process Relay 1x Alarm Relay Both Form C, 1 A, 30 V DC |
| User Interface | 5.7 in LCD with touchscreen |
| Data Logging | SD Card (8 GB supplied) and USB interface. Supports SD Card (FAT-32) – 32 GB max. that allows 24 million logs or 560 days, logging at 2 s intervals |
| Environmental Conditions | +10 °C to +35 °C (+50 °F to +95 °F) |
| Power Supply | 100 Vac to 240 Vac |
| Power Consumption | 580 VA |
| Mechanical Specification | |
| Dimensions (L x W x H) | 480 mm x 440 mm x 185 mm (18.9 in x 17.32 in x 7.28 in) |
| Weight | 22 kg/48.5 lb (instrument only) 26 kg/57.3 lb (with HTLs) |
| Sample Gas Connections | Inlet and Outlets: ¼ in Swagelok tube |
| General | |
| Calibration | 5-point UKAS calibration to +90 °Cdp (+194 °Fdp) |

* Measurement accuracy means maximum deviation between instrument under test and corrected reference. To this must be added the uncertainties associated with the calibration system and the environmental conditions during testing or subsequent use.

A.1 Dimensions

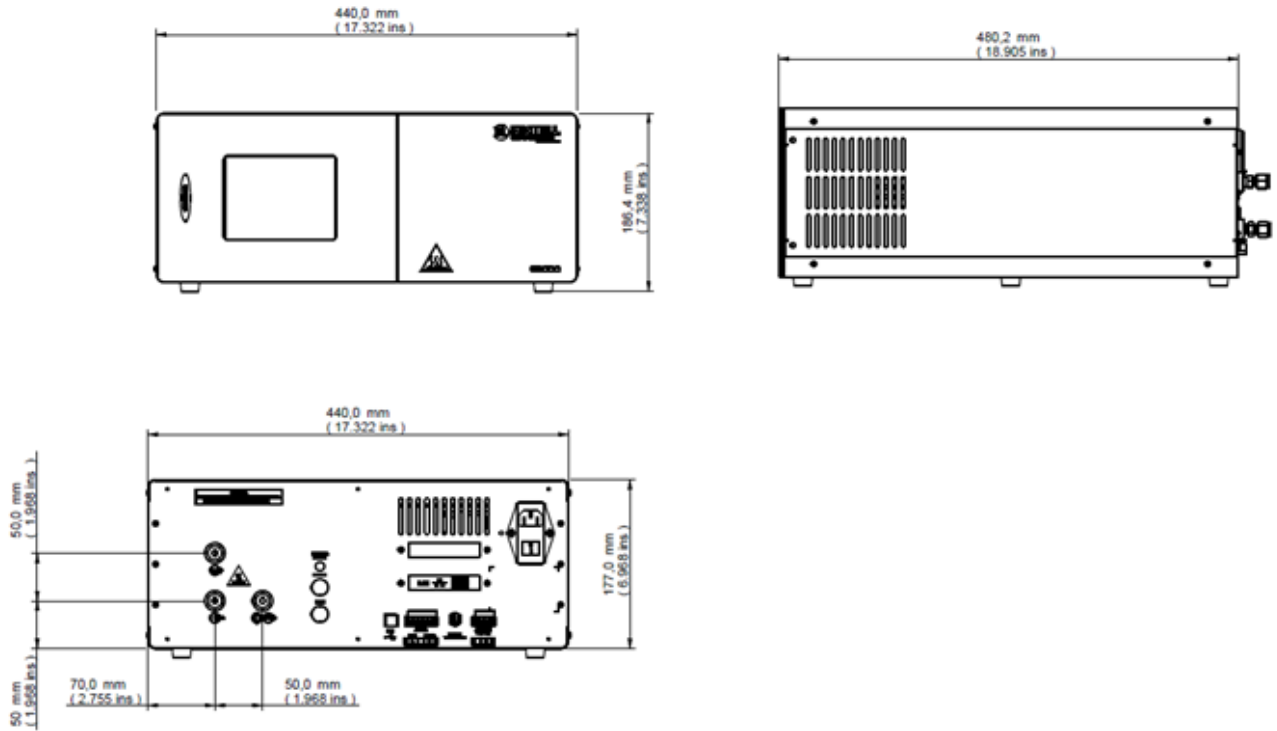

Appendix B

Modbus Register Map

Appendix B Modbus Register Map

| Register Types | |
|----------------|---|
| Type | Description |
| uint16 | unsigned 16 bit value |
| uint32 | unsigned 32 bit value over two registers Register names ending with _MS contain the upper 16 bits Register names ending with _LS contain the lower 16 bits |
| flags | unsigned 16 bit value where each bit represents a flag, value can be a combination of flags |
| float | IEEE754 binary32 compatible floating point number Register names ending with _MS contain the upper 16 bits including the sign and exponent Register names ending with _LS contain the lower 16 bits |
| boolean | unsigned 16 bit value with only two valid values, 0 = off/disabled/no, 1 = on/enabled/yes |

| Address | Access | Data Type | Register Map Definition | Max. | Min. | Default |
|---------------------------------------|--------|-----------|-------------------------------|------------|-------|---------|
| Instrument Info | | | | | | |
| 0 | RIWIF | uint16 | MODBUS_ADDRESS | 255 | 1 | 1 |
| 1 | R | uint16 | INSTRUMENT_ID | 42251 | 42251 | 42255 |
| 2 | R | uint32 | INSTRUMENT_SERIAL_MS | 4294967295 | 0 | 0 |
| 3 | R | | INSTRUMENT_SERIAL_LS | | | |
| 4 | R | uint16 | INSTRUMENT_FIRMWARE_VERSION | 65535 | 0 | 3000 |
| | | | Version * 1000 (1012 = 1.012) | | | |
| 5 | R | uint16 | REGISTER_MAP_VERSION | 65535 | 0 | |
| | | | Version * 1000 (1012 = 1.012) | | | |
| Measured and Calculated Values | | | | | | |
| 6 | R | float | DEWPOINT_MS [°C/°F] | 1000 | -1000 | N/A |
| 7 | R | | DEWPOINT_LS [°C/°F] | | | |
| 8 | R | float | AMBIENT_TEMP_MS [°C/°F] | 1000 | -1000 | N/A |
| 9 | R | | AMBIENT_TEMP_LS [°C/°F] | | | |
| 10 | R | float | PRESSURE_MS [P] | 1000 | -1000 | N/A |
| 11 | R | | PRESSURE_LS [P] | | | |
| 12 | R | float | RH_MS | 100 | 0 | N/A |
| 13 | R | | RH_LS | | | |
| 14 | R | float | PPMV_MS | 999999.9 | 0 | N/A |
| 15 | R | | PPMV_LS | | | |
| 16 | R | float | PPMW_MS | 999999.9 | 0 | N/A |
| 17 | R | | PPMW_LS | | | |
| 18 | R | float | ABSOLUTE_HUMIDITY_MS | 999999.9 | 0 | N/A |
| 19 | R | | ABSOLUTE_HUMIDITY_LS | | | |
| 20 | R | float | MIXING_RATIO_MS | 2 | 0 | N/A |
| 21 | R | | MIXING_RATIO_LS | | | |
| 22 | R | float | WETBULB_MS [°C/°F] | 1000 | -1000 | N/A |
| 23 | R | | WETBULB_LS [°C/°F] | | | |
| 24 | R | float | WVP_MS | 1000 | -1000 | N/A |
| 25 | R | | WVP_LS | | | |
| 26 | R | float | FLOW_MS | 2000 | 0 | N/A |
| 27 | R | | FLOW_LS | | | |
| 28 | R | float | PERCENT_VOLUME_MS | 100 | 0 | N/A |
| 29 | R | | PERCENT_VOLUME_LS | | | |
| 36 | R | uint16 | TEMPERATURE_UNIT | 1 | 0 | 0 |
| | | | 0 = °C 1 = °F | | | |

| Address | Access | Data Type | Register Map Definition | Max. | Min. | Default |
|--------------------------|--------|-----------|---|-------|------|---------|
| 37 | R | uint16 | PRESSURE_UNIT | 4 | 0 | 3 |
| | | | 0 = PSIG 1 = PSIA 2 = BARG 3 = BARA 4 = KPA | | | |
| 38 | R | uint16 | DECIMAL_PLACES | 3 | 1 | 2 |
| Instrument Status | | | | | | |
| 45 | R | uint16 | OPERATING_MODE | 14 | 0 | N/A |
| | | | 0 = NO_CHANGE 1 = SYSTEM_FAILURE 2 = STANDBY 3 = MEASURE 4 = DCC 5 = HOLD 6 = FAST 7 = MAXCOOL 8 = FLOOD_RECOVER 9 = PRT_SWITCH | | | |
| 46 | R | uint16 | MODE_HRS_LEFT | 100 | 0 | N/A |
| 47 | R | uint16 | MODE_MINS_LEFT | 60 | 0 | N/A |
| 48 | R | uint16 | MODE_SECS_LEFT | 60 | 0 | N/A |
| 49 | R | uint16 | SENSOR_STATUS | 4 | 0 | N/A |
| | | | 0 = Unknown 1 = Cooling 2 = Heating 3 = In-Control 4 = Idle | | | |
| 50 | R | flags | FAULT_STATUS_1 | 65535 | 0 | 0 |
| | | | 32768 = Mirror PRT failure 16384 = Ambient PRT failure 8192 = Chiller PRT failure 4096 = Sensor thermistor failure 2048 = Mirror temperature too high 1024 = Stirling emergency error 512 = Optics setpoint search failed 256 = Optics outside max. operating limit 128 = Optics outside min. operating limit 64 = Cooling saturated timeout 32 = Heating saturated timeout 16 = RESERVED 8 = Pressure input failure 4 = Optics contamination 0 = No flags (OK) | | | |
| 51 | R | flags | FAULT_STATUS_2 | 65535 | 0 | 0 |
| | | | 32768 = AMBIENT_PRT_OPEN_CIRCUIT 16384 = PRESSURE_INPUT_OPEN_CIRCUIT 2048 = FLASH_LOADING_FAILED 1024 = FLASH_SAVING_FAILED 0 = NO FLAGS (OK) | | | |
| | | | RESERVED | | | |
| 53 | R | flags | ALARMS_STATUS | 3 | 0 | 0 |
| | | | 0 = No Alarm 1 = System 2 = Process | | | |
| | | | RESERVED | | | |

| Address | Access | Data Type | Register Map Definition | Max. | Min. | Default |
|--|--------|-----------|--|----------|-----------|---------|
| Additional Operating Values | | | | | | |
| 55 | R | uint16 | LOGGING_STATUS | 9 | 0 | 0 |
| | | | 0 = Not Fitted 1 = No Card 2 = Ready 3 = Logging 4 = Writing 5 = Mount Error 6 = Write Error 7 = Mounting 8 = Write Protected 9 = Unknown | | | |
| 56 | R | boolean | DATA_HOLD_ACTIVE | 1 | 0 | 0 |
| 57 | R | boolean | DISPLAY_HOLD_ACTIVE | 1 | 0 | 0 |
| 58 | R | uint16 | PRT_MODE | 1 | 0 | 0 |
| | | | 0 = Internal PRT Measurement 1 = External PRT Measurement | | | |
| 80 | R | float | FILM_THICKNESS_MS | 16777215 | 0 | N/A |
| 81 | R | | FILM_THICKNESS_LS | | | |
| 82 | R | uint16 | OPTICS_CONDITION | 200 | 0 | N/A |
| | | | 200 % = double film 100 % = correct film 0 % = zero film | | | |
| 83 | R | int16 | PELTIER_DRIVE_PERCENT | 100 | -100 | N/A |
| 84 | R | float | CFNG_TEMP_MS [°C/°F] | 80 | -100 | N/A |
| 85 | R | | CFNG_TEMP_LS [°C/°F] | | | |
| 86 | R | flags | CFNG_STATUS | 7 | 0 | N/A |
| | | | 0 = OK 1 = emergency alarm (chiller shutdown) 2 = input out of range alarm 4 = temperature / vibration alarm (temporary chiller shutdown) | | | |
| 87 | R | uint16 | CFNG_MODE | 1 | 0 | N/A |
| | | | 0 = Automatic setpoint 1 = Manual setpoint | | | |
| 88 | R | float | CFNG_SETPOINT_MS [°C/°F] | [40 °C] | [-100 °C] | N/A |
| 89 | R | | CFNG_SETPOINT_LS [°C/°F] | | | |
| 90 | R | | HTL_IN_TEMP_MS [°C/°F] | 110 | 25 | |
| 91 | R | | HTL_IN_TEMP_LS [°C/°F] | | | |
| 92 | R | | HTL_OUT_TEMP_MS [°C/°F] | 110 | 25 | |
| 93 | R | | HTL_OUT_TEMP_LS [°C/°F] | | | |
| User Configuration – Calculation Parameters | | | | | | |
| 200 | RIWIF | uint16 | SET_TEMP_UNIT | 1 | 0 | 0 |
| | | | 0 = °C 1 = °F | | | |
| 201 | RIWIF | uint16 | SET_PRESSURE_UNIT | 4 | 0 | 3 |
| | | | 0 = PSIG 1 = PSIA 2 = BARG 3 = BARA 4 = KPA | | | |
| 202 | RIWIF | float | ATMOSPHERIC_PRESSURE_MS [P] | 999999.9 | 0 | 1.01325 |
| 203 | RIWIF | | ATMOSPHERIC_PRESSURE_LS [P] | | | |
| 204 | RIWIF | boolean | PRESSURE_CORRECTION_ENABLED | 1 | 0 | 0 |
| | | | 0 = off 1 = on | | | |

| Address | Access | Data Type | Register Map Definition | Max. | Min. | Default |
|--|--------|-----------|--|------------|------------|-----------|
| 205 | RIWIF | boolean | FORCE_WATER | 1 | 0 | 0 |
| | | | 0 = off 1 = on | | | |
| 206 | RIWIF | boolean | RH_WMO | 1 | 0 | 0 |
| | | | 0 = off 1 = on | | | |
| 207 | RIWIF | boolean | PPM _v _ON_WET | 1 | 0 | 0 |
| | | | 0 = off (dry) 1 = on (wet) | | | |
| 208 | RIWIF | float | MOL_WEIGHT_MS | 999999.9 | 0 | 28.9645 |
| 209 | RIWIF | | MOL_WEIGHT_LS | | | |
| User configuration – DCC/FAST | | | | | | |
| 220 | RIWIF | boolean | DCC_SETPOINT_MODE | 1 | 0 | 1 |
| | | | 0 = absolute 1 = relative | | | |
| 221 | RIWIF | int16 | DCC_TEMPERATURE [°C/°F**] | 25000 | 0 | 2000 |
| | | | setpoint in degrees = value / 100 | | | |
| 222 | RIWIF | boolean | DCC_INTERVAL_MODE | 1 | 0 | 0 |
| | | | 0 = manual dcc's 1 = auto (timed) dcc's | | | |
| 223 | RIWIF | uint16 | DCC_INTERVAL_MINS | 65535 | 0 | 240 |
| 224 | RIWIF | uint16 | DCC_DURATION_MINS | 65535 | 0 | 2 |
| 225 | RIWIF | float | FAST_SETPOINT_MS [°C/°F] | [-2 °C] | [-22 °C] | [-3 °C] |
| 226 | RIWIF | | FAST_SETPOINT_LS [°C/°F] | | | |
| 227 | RIWIF | boolean | FAST_ENABLE | 1 | 0 | 1 |
| | | | 0 = disabled 1 = enabled | | | |
| | | | RESERVED | | | |
| 229 | RIWIF | uint16 | STABILITY_BAND [°C/°F] | [20.0 °C] | [0.1 °C] | [0.2 °C] |
| | | | band (degrees) = value / 1000 | | | |
| User configuration – Chiller | | | | | | |
| 236 | RIWIF | float | SENS_HTR_SENSOR_SETPOINT_MS [°C/°F] | [110.0 °C] | [25.0 °C] | [25.0 °C] |
| 237 | RIWIF | | SENS_HTR_SENSOR_SETPOINT_LS [°C/°F] | | | |
| User configuration – Hold Settings | | | | | | |
| 238 | RIWIF | uint16 | DATA_HOLD_TIMEOUT_MINS | 60 | 20 | 45 |
| 239 | RIWIF | boolean | ENABLE_DATA_HOLD | 1 | 0 | 1 |
| | | | 0 = disabled 1 = enabled | | | |
| User configuration – Temperature Sensor | | | | | | |
| 240 | RIWIF | boolean | AMBIENT_SENSOR_SOURCE | 1 | 0 | 0 |
| | | | 0 = External 1 = Manual | | | |
| 241 | RIWIF | float | MANUAL_AMBIENT_MS [°C/°F] | [150.0 °C] | [-60.0 °C] | [23.0 °C] |
| 242 | RIWIF | | MANUAL_AMBIENT_LS [°C/°F] | | | |
| User configuration – Pressure Sensor | | | | | | |
| | | | RESERVED | | | |
| | | | RESERVED | | | |
| | | | RESERVED | | | |
| | | | RESERVED | | | |

| Address | Access | Data Type | Register Map Definition | Max. | Min. | Default |
|--|--------|-----------|---|-----------|------|---------|
| User configuration – Analog Output Settings | | | | | | |
| 270 | RIWIF | uint16 | ANALOG_1_TYPE | 2 | 0 | 1 |
| | | | 0 = 0 mA to 20 mA 1 = 4 mA to 20 mA 2 = 0-1V | | | |
| 271 | RIWIF | uint16 | ANALOG_1_PARAMETER | 9 | 0 | 0 |
| | | | 0 = Dew point 1 = Temperature 2 = Pressure 3 = %rh 4 = Water content: ppm _v 5 = Water content: ppm _w 6 = Mixing ratio 7 = Absolute humidity 8 = Wetbulb 9 = Water vapour pressure 10 = Water content: percent volume 11 = Flow | | | |
| 272 | RIWIF | float | ANALOG_1_RANGE_LOW_MS | 1999999.9 | -300 | -50 |
| 273 | RIWIF | | ANALOG_1_RANGE_LOW_LS | | | |
| 274 | RIWIF | float | ANALOG_1_RANGE_HIGH_MS | 1999999.9 | -300 | 50 |
| 275 | RIWIF | | ANALOG_1_RANGE_HIGH_LS | | | |
| 276 | RIWIF | uint16 | ANALOG_1_ALARM_SOURCE | 3 | 0 | 0 |
| | | | 0 = None 1 = System 2 = Process 3 = System & Process | | | |
| | | | RESERVED | | | |
| 279 | RIWIF | uint16 | ANALOG_2_TYPE | 2 | 0 | 1 |
| | | | 0 = 0 mA to 20 mA 1 = 4 mA to 20 mA 2 = 0-1V | | | |
| 280 | RIWIF | uint16 | ANALOG_2_PARAMETER | 9 | 0 | 1 |
| | | | 0 = Dew point 1 = Temperature 2 = Pressure 3 = %rh 4 = Water content: ppm _v 5 = Water content: ppm _w 6 = Mixing ratio 7 = Absolute humidity 8 = Wetbulb 9 = Water vapour pressure 10 = Water content: percent volume 11 = Flow | | | |
| 281 | RIWIF | float | ANALOG_2_RANGE_LOW_MS | 1999999.9 | -300 | 0 |
| 282 | RIWIF | | ANALOG_2_RANGE_LOW_LS | | | |
| 283 | RIWIF | float | ANALOG_2_RANGE_HIGH_MS | 1999999.9 | -300 | 100 |
| 284 | RIWIF | | ANALOG_2_RANGE_HIGH_LS | | | |
| 285 | RIWIF | uint16 | ANALOG_2_ALARM_SOURCE | 3 | 0 | 0 |
| | | | 0 = None 1 = System 2 = Process 3 = System & Process | | | |

| Address | Access | Data Type | Register Map Definition | Max. | Min. | Default |
|--|--------|-----------|---|-----------|------|---------|
| User configuration – Process Alarm Settings | | | | | | |
| 290 | RIWIF | uint16 | PROCESS_ALARM_PARAMETER | 11 | 0 | 0 |
| | | | 0 = Dew point 1 = Temperature 2 = Pressure 3 = %rh 4 = Water content: ppm _v 5 = Water content: ppm _w 6 = Mixing ratio 7 = Absolute humidity 8 = Wetbulb 9 = Water vapour pressure 10 = Water content: percent volume 11 = Flow | | | |
| 291 | RIWIF | uint16 | PROCESS_ALARM_TYPE | 4 | 0 | 1 |
| | | | 0 = Off 1 = Over setpoint 2 = Under setpoint 3 = Inside band 4 = Outside band | | | |
| 292 | RIWIF | float | PROCESS_ALARM_HYSTER_MS | 300 | 0 | 0.2 |
| 293 | RIWIF | | PROCESS_ALARM_HYSTER_LS | | | |
| 294 | RIWIF | float | PROCESS_ALARM_SETPOINT_A_MS | 1999999.9 | -300 | -10 |
| 295 | RIWIF | | PROCESS_ALARM_SETPOINT_A_LS | | | |
| 296 | RIWIF | float | PROCESS_ALARM_SETPOINT_B_MS | 1999999.9 | -300 | 0 |
| 297 | RIWIF | | PROCESS_ALARM_SETPOINT_B_LS | | | |
| 298 | RIWIF | boolean | PROCESS_ALARM_OPTICS | 1 | 0 | 0 |
| | | | 0 = Off 1 = Optics warning activates process alarm | | | |
| User configuration – System Alarm Settings | | | | | | |
| 301 | RIWIF | boolean | NOT_MEASURE_ALARM | 1 | 0 | 0 |
| | | | 0 = Off 1 = System alarm activated when not in measurement mode | | | |
| | | | RESERVED | | | |
| 304 | RIWIF | uint16 | SET_SERIAL_TYPE | 65535 | 0 | 0 |
| | | | 737 = Activate legacy serial comms mode (replaces Modbus) | | | |
| User configuration – Ethernet | | | | | | |
| 310 | R | uint16 | ETH_STATUS | 2 | 0 | 0 |
| | | | 0 = Error / Not fitted 1 = OK 2 = Configuring | | | |
| 311 | RIW | uint16 | ETH_IP_1 | 255 | 0 | 0 |
| 312 | RIW | uint16 | ETH_IP_2 | 255 | 0 | 0 |
| 313 | RIW | uint16 | ETH_IP_3 | 255 | 0 | 0 |
| 314 | RIW | uint16 | ETH_IP_4 | 255 | 0 | 0 |
| 315 | RIW | uint16 | ETH_SUBNET_1 | 255 | 0 | 0 |
| 316 | RIW | uint16 | ETH_SUBNET_2 | 255 | 0 | 0 |
| 317 | RIW | uint16 | ETH_SUBNET_3 | 255 | 0 | 0 |
| 318 | RIW | uint16 | ETH_SUBNET_4 | 255 | 0 | 0 |
| 319 | RIW | uint16 | ETH_GATEWAY_1 | 255 | 0 | 0 |
| 320 | RIW | uint16 | ETH_GATEWAY_2 | 255 | 0 | 0 |
| 321 | RIW | uint16 | ETH_GATEWAY_3 | 255 | 0 | 0 |

| Address | Access | Data Type | Register Map Definition | Max. | Min. | Default |
|--|--------|-----------|--|----------|------|---------|
| 322 | RIW | uint16 | ETH_GATEWAY_4 | 255 | 0 | 0 |
| User configuration – RTC | | | | | | |
| 330 | RIW | uint16 | RTC_YEAR | 99 | 17 | N/A |
| 331 | RIW | uint16 | RTC_MONTH | 12 | 1 | N/A |
| 332 | RIW | uint16 | RTC_DAY | 31 | 1 | N/A |
| 333 | RIW | uint16 | RTC_HOURS | 24 | 0 | N/A |
| 334 | RIW | uint16 | RTC_MINUTES | 59 | 0 | N/A |
| User configuration – Display Parameters | | | | | | |
| 336 | RIWIF | uint16 | DECIMAL_PLACES | 3 | 1 | 2 |
| 337 | RIWIF | boolean | ENABLE_DISPLAY_HOLD | 1 | 0 | 0 |
| | | | 0 = Disabled 1 = Enabled | | | |
| 338 | RIWIF | uint16 | PARAMETER_1 | 11 | 0 | 0 |
| | | | 0 = Dewpoint 1 = Temperature 2 = Pressure 3 = %rh 4 = Water content: ppm _v 5 = Water content: ppm _w 6 = Mixing ratio 7 = Absolute humidity 8 = Wetbulb 9 = Water vapour pressure 10 = Water content: percent volume 11 = Flow | | | |
| 339 | RIWIF | uint16 | PARAMETER_2 | 11 | 0 | 1 |
| | | | as PARAMETER_1 above | | | |
| 340 | RIWIF | uint16 | PARAMETER_3 | 11 | 0 | 11 |
| | | | as PARAMETER_1 above | | | |
| | | | RESERVED | | | |
| 400 | RIWIF | boolean | FLOOD_DETECT_ENABLE | 1 | 0 | 0 |
| 401 | RIWIF | float | DP_SEARCH_TEMP_LIMIT_MS [°C only] | 120 | -150 | -100 |
| 402 | RIWIF | | DP_SEARCH_TEMP_LIMIT_LS [°C only] | | | |
| 410 | RIWIF | uint16 | PRT_MODE | 1 | 0 | 0 |
| | | | 0 = Internal PRT Measurement 1 = External PRT Measurement | | | |
| Advanced User Debug | | | | | | |
| 800 | R | uint16 | OPTICS_DRIVE | 65535 | 0 | N/A |
| 801 | R | uint32 | REFLECTED_READING_MS | 16777215 | 0 | N/A |
| 802 | R | | REFLECTED_READING_LS | | | |
| 803 | R | uint32 | SCATTERED_READING_MS | 16777215 | 0 | N/A |
| 804 | R | | SCATTERED_READING_LS | | | |
| 805 | R | float | RATIO_READING_MS | 100 | -100 | N/A |
| 806 | R | | RATIO_READING_LS | | | |
| 807 | R | uint32 | DCC_REFLECTED_MS | 16777215 | 0 | N/A |
| 808 | R | | DCC_REFLECTED_LS | | | |
| 809 | R | uint32 | DCC_SCATTERED_MS | 16777215 | 0 | N/A |
| 810 | R | | DCC_SCATTERED_LS | | | |
| 811 | R | float | DCC_RATIO_MS | 100 | -100 | N/A |
| 812 | R | | DCC_RATIO_LS | | | |
| 813 | R | uint32 | CLEAN_REFLECTED_MS | 16777215 | 0 | N/A |
| 814 | R | | CLEAN_REFLECTED_LS | | | |

| Address | Access | Data Type | Register Map Definition | Max. | Min. | Default |
|--|--------|-----------|---|------------|------|---------|
| 815 | R | uint32 | CLEAN_SCATTERED_MS | 16777215 | 0 | N/A |
| 816 | R | | CLEAN_SCATTERED_LS | | | |
| 817 | R | uint16 | CLEAN_DRIVE_LEVEL | 65535 | 0 | N/A |
| User configuration – Feature Unlock | | | | | | |
| 900 | R | uint32 | SECURITY_CODE_MS | 4294967295 | 0 | ~ |
| 901 | R | | SECURITY_CODE_LS | | | |
| 902 | W | uint32 | FEATURE_CODE_MS | 4294967295 | 0 | N/A |
| 903 | W | | FEATURE_CODE_LS | | | |
| 904 | R | uint16 | FEATURE_FEEDBACK / RESERVED | 65535 | 0 | N/A |
| Instrument Control | | | | | | |
| 1000 | W | uint16 | SET_MODE | 16 | 0 | N/A |
| | | | 1 = Standby 2 = DCC 4 = Maxcool 8 = Cancel maxcool 16 = Calibrate optics (optics reset) | | | |
| Debugging / Live Calibration – Ethernet | | | | | | |
| 2770 | R | uint16 | REG_ETH_DEBUG_CODE | 0 | 0 | N/A |
| | | | 0 = OK 1 = IDLE 2 = CONFIGURING 3 = FAIL_CONFIG_TIMEOUT 4 = FAIL_CONFIG_RESPONSE 5 = FAIL_MENU_TIMEOUT 6 = FAIL_MENU_RESPONSE 7 = FAIL_DISCARD_MENU_TIMEOUT 8 = FAIL_SETTINGS_TIMEOUT 9 = FAIL_WAIT_IP_TIMEOUT 10 = FAIL_WAIT_IP_RESPONSE 11 = FAIL_WAIT_GATEWAY_TIMEOUT 12 = FAIL_WAIT_GATEWAY_RESPONSE 13 = FAIL_WAIT_SUBNET_TIMEOUT 14 = FAIL_WAIT_SUBNET_RESPONSE 15 = FAIL_WAIT_TELNET_TIMEOUT 16 = FAIL_WAIT_TELNET_RESPONSE 17 = FAIL_WAIT_SAVE_TIMEOUT 18 = FAIL_WAIT_SAVE_RESPONSE 19 = FAIL_WAIT_SAVED_TIMEOUT 20 = FAIL_DISCARD_SAVE_TIMEOUT 21 = FAIL_GET_SETTINGS | | | |

Appendix C

Quality, Recycling & Warranty Information

Appendix C Quality, Recycling & Warranty Information

Michell Instruments is dedicated to complying to all relevant legislation and directives. Full information can be found on our website at:

www.ProcessSensing.com/en-us/compliance

This page contains information on the following directives:

- ATEX Directive
- Calibration Facilities
- Conflict Minerals
- FCC Statement
- Manufacturing Quality
- Pressure Equipment Directive
- REACH
- RoHS
- WEEE
- Recycling Policy
- Warranty and Returns

This information is also available in PDF format.

Appendix D

Return Document & Decontamination Declaration

Appendix D Return Document & Decontamination Declaration



Decontamination Certificate

IMPORTANT NOTE: Please complete this form prior to this instrument, or any components, leaving your site and being returned to us, or, where applicable, prior to any work being carried out by a Michell engineer at your site.

| | | | | |
|--|-----|----|----------------|---------------|
| Instrument | | | Serial Number | |
| Warranty Repair? | YES | NO | Original PO # | |
| Company Name | | | Contact Name | |
| Address | | | | |
| Telephone # | | | E-mail address | |
| Reason for Return /Description of Fault: | | | | |
| Has this equipment been exposed (internally or externally) to any of the following? Please circle (YES/NO) as applicable and provide details below | | | | |
| Biohazards | | | YES | NO |
| Biological agents | | | YES | NO |
| Hazardous chemicals | | | YES | NO |
| Radioactive substances | | | YES | NO |
| Other hazards | | | YES | NO |
| Please provide details of any hazardous materials used with this equipment as indicated above (use continuation sheet if necessary) | | | | |
| Your method of cleaning/decontamination | | | | |
| Has the equipment been cleaned and decontaminated? | | | YES | NOT NECESSARY |
| Michell Instruments will not accept instruments that have been exposed to toxins, radio-activity or bio-hazardous materials. For most applications involving solvents, acidic, basic, flammable or toxic gases a simple purge with dry gas (dew point <-30°C) over 24 hours should be sufficient to decontaminate the unit prior to return. Work will not be carried out on any unit that does not have a completed decontamination declaration. | | | | |
| Decontamination Declaration | | | | |
| I declare that the information above is true and complete to the best of my knowledge, and it is safe for Michell personnel to service or repair the returned instrument. | | | | |
| Name (Print) | | | Position | |
| Signature | | | Date | |



03922 v1.1, February 2026



processsensing.com | dwyeromega.com

