

OXY-FLEX Series Oxygen Transmitter User Manual PST-UM-1400-EN-03



Issue No.	Description	Date
01	Issue 01 to the new PST style guide.	October 2021
02	Metadata update, no information change. Issue update required.	November 2021
03	Update to the supply current in the electrical table. Addition of the compliance appendix.	March 2022

Table of Contents

1	Definitions.....	5
2	Abbreviations.....	5
3	Introduction.....	6
3.1	Intended use of the OXY-FLEX Series Oxygen Transmitter	6
3.2	Product Overview	6
4	Safety Instructions	7
5	Technical Description.....	8
5.1	External Dimensions	8
5.2	Performance Specifications.....	10
5.3	Mechanical Specifications	11
5.4	Electrical Input / Output Specifications	11
5.5	Operating Conditions	11
6	Installation.....	12
6.1	Mounting Instructions.....	12
6.2	Electrical Connections.....	13
6.3	Connector Housing.....	14
6.4	System Block Diagram.....	14
6.5	PCB Layout.....	15
7	Initial Startup.....	15
7.1	Commissioning Checks.....	15
7.2	Switching ON the Device.....	16
7.3	First Time Calibration	16
8	System Configuration.....	17
8.1	Setting the Output Type	18
8.2	Setting the Calibration Type and Measurement Range.....	19
8.3	Digital Variant – RS232 Output	20
8.4	Menu Security Password.....	21
8.5	Automatic Calibration Value.....	21
8.6	Variable Output Filtering (T _d Averaging).....	21
8.7	Analog Output Minimum and Maximum Ranges	22
8.8	Analog Variants.....	24
9	Operation	24
9.1	Operating Tips.....	24
9.2	RS232 Operation.....	24
9.3	Continuous Data Streaming.....	24
9.4	Menu Screens	25
10	Maintenance.....	26

10.1	Calibrating	26
10.2	Automatic Calibration	27
10.3	Manual Calibration	27
10.4	Error Conditions	28
10.5	Cleaning	28
10.6	Disposal	28
11	Appendix A – Menu Structure	29
12	Appendix B – Quality, Recycling & Warranty Information	33

1 Definitions

The following definitions apply to WARNINGS, CAUTIONS, and NOTES used throughout this guide.

WARNING:

The warning symbol is used to indicate instructions that, if they are not followed, can result in minor, serious or even fatal injuries to personnel.

CAUTION:

The caution symbol is used to indicate instructions that, if they are not followed, can result in damage to the equipment (hardware and/or software), or a system failure occurring.

NOTE: Highlights an essential operating procedure, condition, or statement.

2 Abbreviations

The following abbreviations are used in the guide:

AC	Alternating Current
DC	Direct Current
°C	Degrees Celsius
°F	Degrees Fahrenheit
mA	Milliampere
PLC	Programmable Logic Controller
GND	Ground
LED	Light-emitting Diode
PC	Personal Computer
PCB	Printed Circuit Board

3 Introduction

This manual is applicable to the following OXY-FLEX series oxygen transmitters.

XZR200 with aluminum housing (Probe mounted on housing).

XZR201 with aluminum housing (Probe connected via cable).

XZR210 with stainless-steel housing (Probe mounted on housing).

XZR211 with stainless-steel housing (Probe connected via cable).

3.1 Intended use of the OXY-FLEX Series Oxygen Transmitter

The OXY-FLEX Series of oxygen transmitters are designed to determine the oxygen concentration in air or inert gas mixtures in areas that are not easily accessible or in closed systems, such as ventilation pipes, flues, and containers.

The OXY-FLEX Series high-temperature oxygen transmitter is designed for use in air or inert gas mixtures with temperatures of $-100\text{ }^{\circ}\text{C} / -148\text{ }^{\circ}\text{F}$ to $+400\text{ }^{\circ}\text{C} / 750\text{ }^{\circ}\text{F}$ maximum.

The actual oxygen sensor is mounted in the tip of the stainless-steel probe and is protected by a stainless-steel sintered cap which acts as a large particulate filter.

The die-cast aluminum or stainless steel housing accommodates the electronics.

3.2 Product Overview

The OXY-FLEX Series of transmitters are housed in a sealed, die-cast aluminum or stainless-steel enclosure with an attached oxygen sensor probe and M12, 8 Pin, A Coded connector.

Main Components

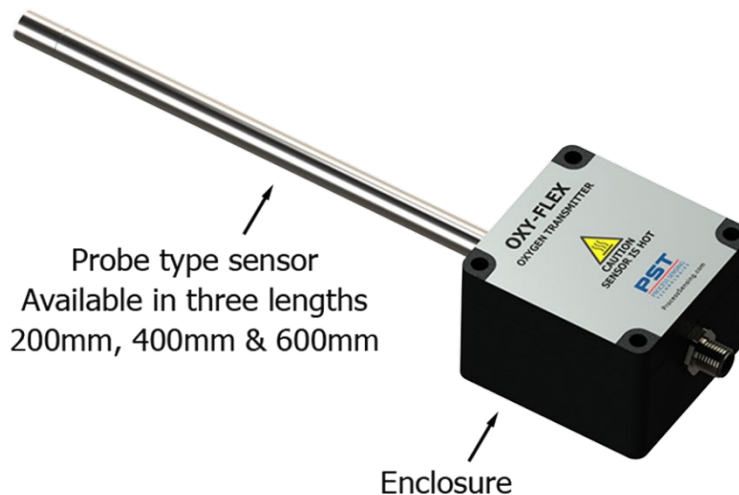

4 Safety Instructions

- This equipment may only be installed by a suitably qualified technician in accordance with the instructions in this manual and any applicable standards associated with the country or industry.
- Failure to correctly adhere to these instructions may result in severe injury or death, and in this regard, the manufacturer will not be held liable.
- This equipment may only be operated and maintained by trained technical personnel. The technical personnel must strictly adhere to the instructions given in this manual, and any prevailing standards/certificates (depending on application).
- The operator may only perform modifications and repairs to the equipment/system with the written approval of the manufacturer.
- Do NOT operate damaged equipment.
- If faults cannot be rectified, the equipment must be taken out of service and secured against unintentional commissioning.

5 Technical Description

5.1 External Dimensions

Dimensions are in mm unless otherwise stated.

XZR200 with aluminum housing

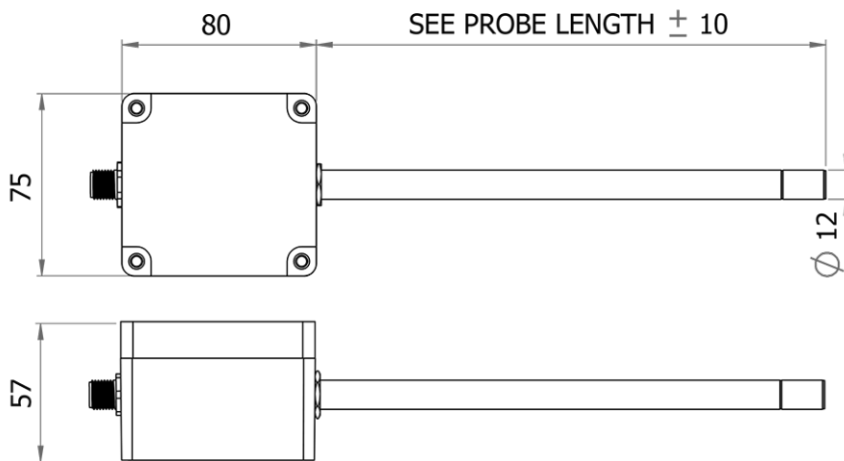

XZR201 with aluminum housing with probe connected via shielded cable

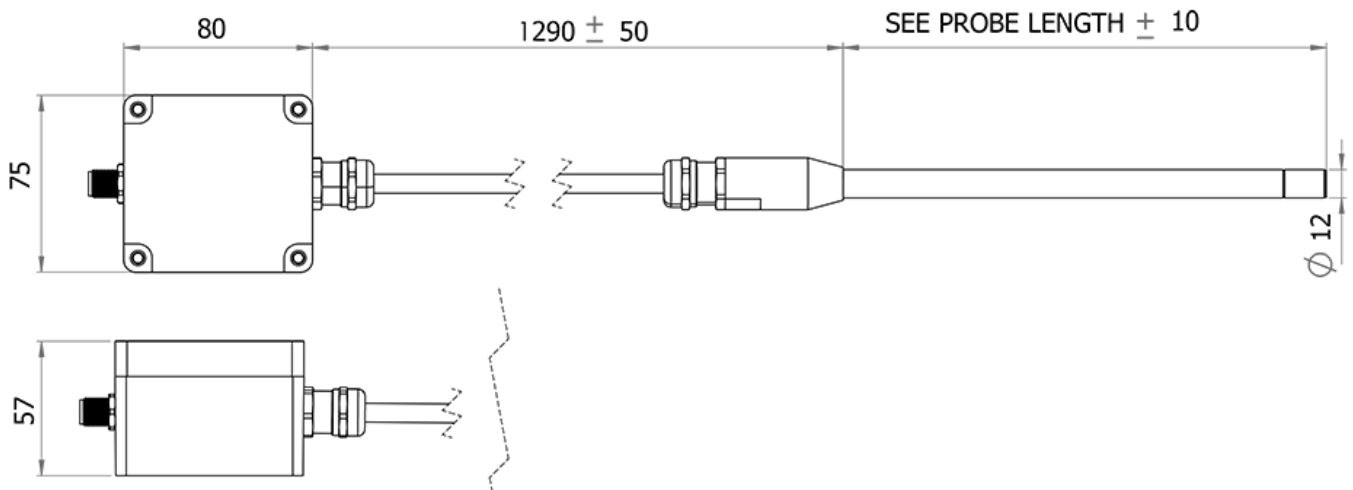

XZR210 with stainless-steel housing

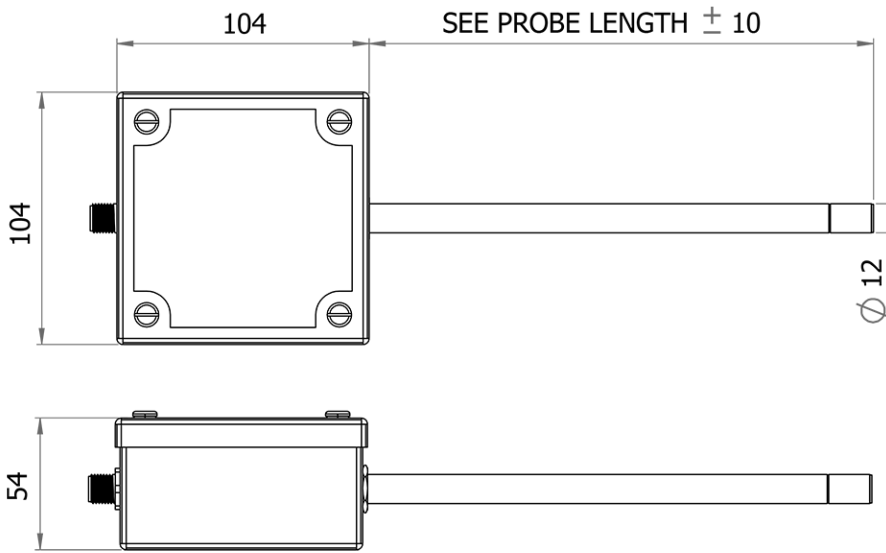

XZR211 with stainless-steel housing with probe connected via shielded cable

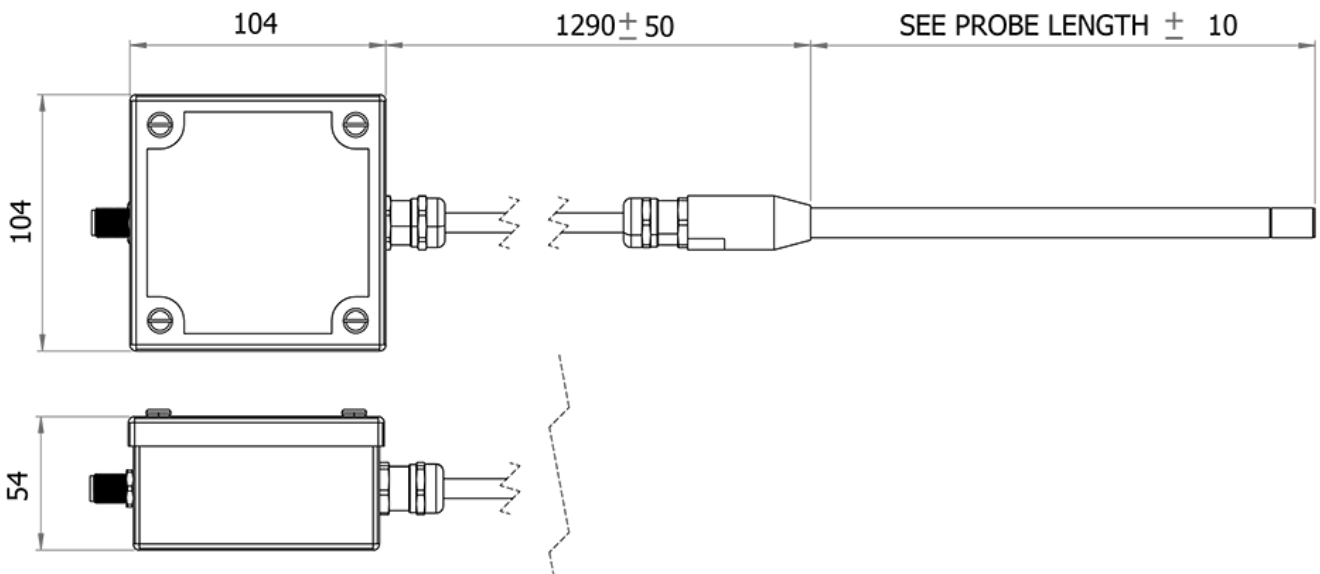

5.2 Performance Specifications

Performance	
Measurement Technology	Zirconia
Gas	Oxygen
Measurement Range	0.1...25 % or 0.1...100 %
Output Resolution	0.01 V, 0.01 mA or 0.01 % O ₂
Accuracy (0-25%)	< 0.5 % O ₂
Accuracy (0-100%)	< 1 % O ₂
Response Time (T10-90)	< 15 seconds
Repeatability	< 0.5 %
Sample Flow Rate	0...10 m/sec
Sample Flow Effect (calibrated @ 0.5 l/min)	±0.1 % O ₂ (0 to 1 l/min)
Sample Pressure	Atmospheric*
Sample Temperature	Up to + 400 °C
Background Gas	Air, N ₂ , CO ₂ , Ar or combustion gas

*The OXY-FLEX Series of transmitters are designed to be operated at atmospheric pressures.

However, it is possible to measure in the range 0.1 to 25% O₂ at pressures up to 3 barg (43.5 psig) without damage to the unit.

The unit will require calibration at the operating pressure, and a separate pressure transducer feeding into the control system may be required.

5.3 Mechanical Specifications

Mechanical Specifications	
Warm Up Time	Approx. 10 minutes
Probe Dimensions	220, 400 or 600 mm (length) ø12 mm
Weight	< 0.5 kg
Wetted Materials	Stainless-steel
Process Connection	12 mm Swagelok® compression fitting or equivalent required
Ingress Protection	IP66
Housing Material	Waterproof die-cast aluminum or stainless-steel housing

5.4 Electrical Input / Output Specifications

Electrical Input / Output	
Supply Voltage	24 V DC, ±10 %
Supply Current	< 1 A Operating @ 24 V DC < 2 A Start-up @ 24 V DC
Analog Outputs	0...10 V DC, 4...20 mA
Comms Output	RS232

5.5 Operating Conditions

Operating Conditions	
Ambient Temperature (Enclosure)	-10 to +85 °C (14 to +185 °F)

! *CAUTION: Risk of damage!*
Prolonged operation below 0.1 % O₂ can damage the sensing element.

6 Installation

Your equipment must be installed correctly by trained technical personnel to ensure the best performance.

! *CAUTION: Risk of damage!*
Protect the device from accidental shock or vibration as this may damage the board.

6.1 Mounting Instructions

Dimensions are in mm unless otherwise stated.

Transmitters with probe attached directly to the housing (XZR200, XZR210): are typically mounted to the process gas / flue as shown in the diagram below.

The recommended 15° down angle on the probe is intended to eliminate the possibility of moisture collecting in the probe tip during combustion applications. In dry applications, this 15° angle is not necessary.

Transmitters with probe connected via shielded cable (XZR201, XZR211): the probe is typically mounted to the process as shown in the diagram below.

Probe mounting & orientation

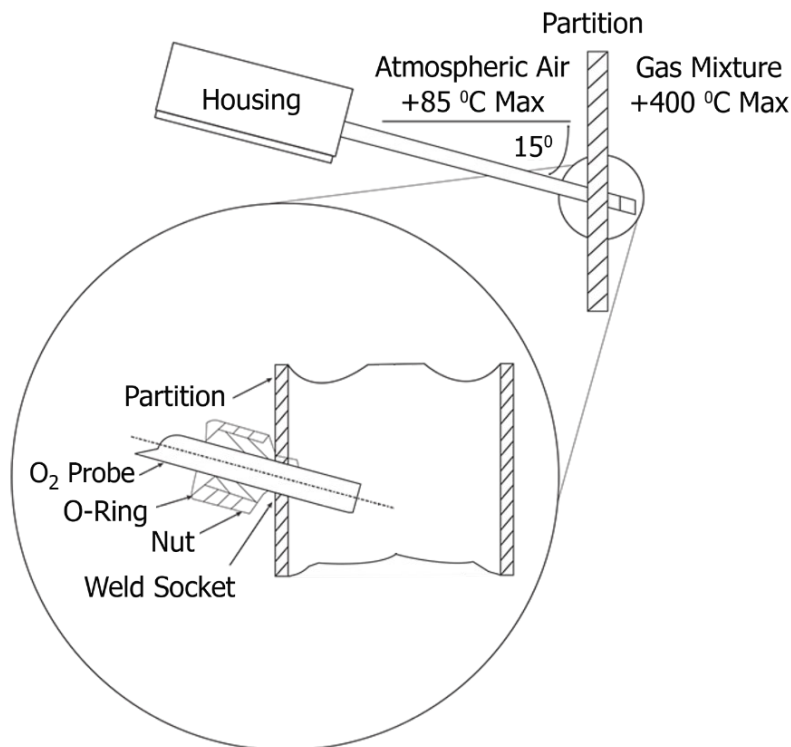

The XZR200, XZR201 housing can be mounted to a flat surface using the mounting holes.

The XZR210, XZR211 housing cannot be mounted directly to a flat surface. The customer must use a suitable bracket of their own design.

Aluminum enclosure mounting holes (XZR200, XZR210)

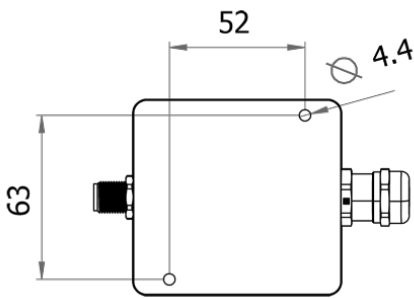

Mounting holes are accessible after removal of the housing lid.

6.2 Electrical Connections



WARNING: Danger of Death

All wiring MUST be in accordance with the National Electrical Code and any local codes, ordinances, and regulations.

Disconnect and lockout power before connecting the equipment to the power supply.

The device wiring should be in a separate conduit.

Do NOT install wiring in any conduit or junction boxes with high voltage wiring.



CAUTION: Risk of damage!

*Do not install the device suspended from the cable.
Avoid exerting excessive tensile force on the cable.*

6.3 Connector Housing

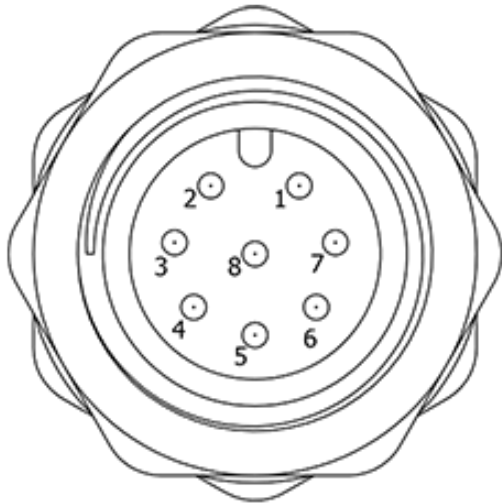

Sensor Connections	
Pin Number	Connection
1	24 V DC \pm 10 %
2	Not Connected
3	0...10 V DC / RS232 Rx
4	4...20 mA / RS232 Tx
5	Cycle
6	Calibrate
7	GND (0 V DC)
8	Not Connected

As seen from outside of housing.
Connector: M12, 8 Pin, A Coded

6.4 System Block Diagram

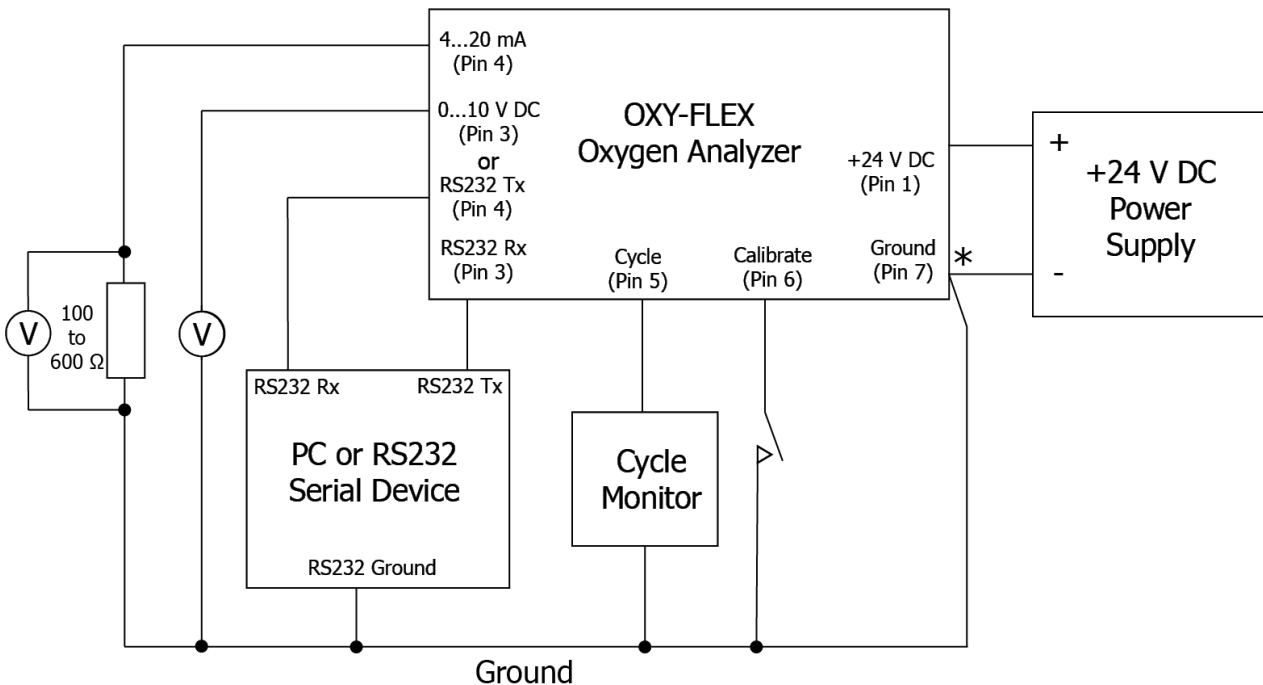

* Output pins 3 and 4 are both referenced to the power supply 0 V DC (pin 7).

Due to high current flow in the supply GND, when monitoring the 0...10 V DC output (pin 6), it is recommended that a separate GND wire for the measurement system is taken from pin 7.

This removes errors due to voltage drops in the power supply connections. Assignment of output pins 3 and 4 selectable by altering the position of the jumper links on the PCB; refer to [PCB Layout](#) in this document.

6.5 PCB Layout

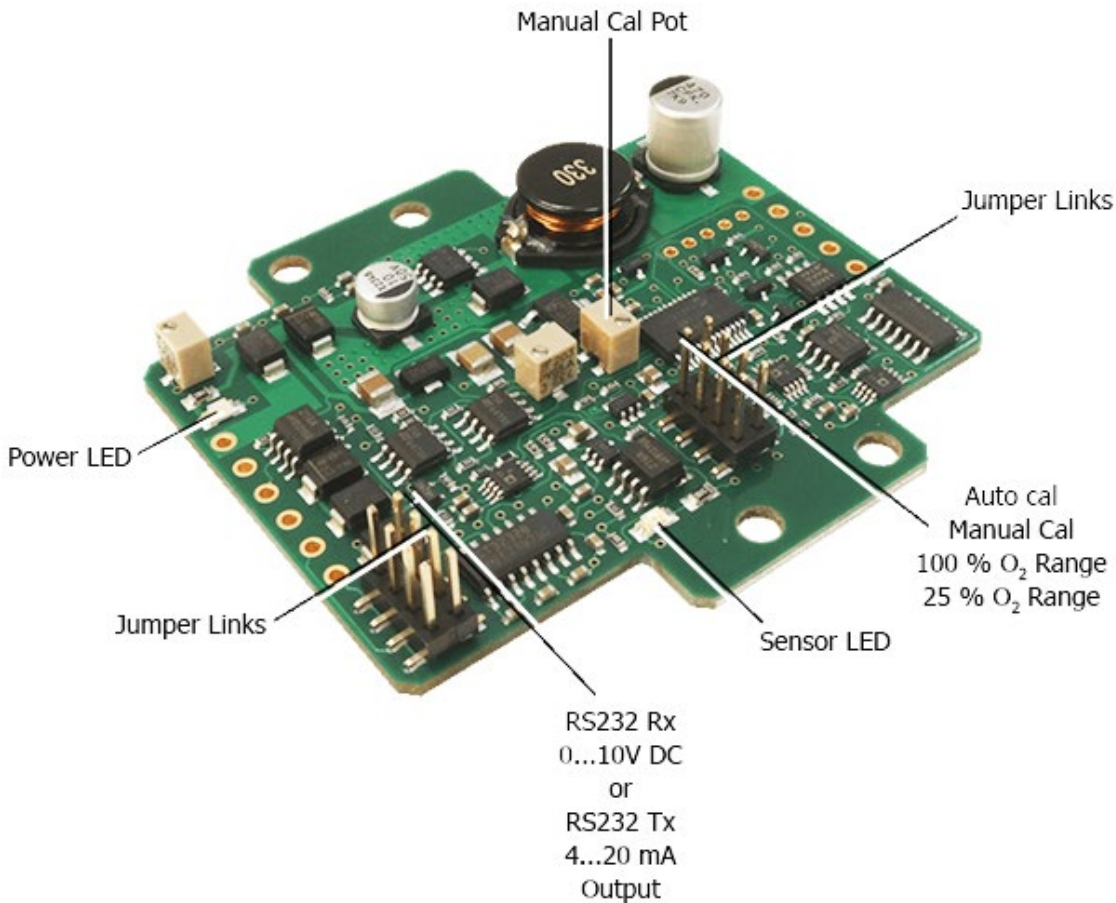

7 Initial Startup

7.1 Commissioning Checks

Before commissioning the equipment, read the [Safety Instructions](#) contained in this document.

Complete the following essential tasks **BEFORE** switching the system **ON** for the first time:

1. Ensure compliance with the permissible installation position.
2. Verify the device is mounted securely and correctly.
3. Verify the device and wiring are all undamaged.
4. Ensure the cables are strain-free.
5. Ensure the device is connected correctly, with all inputs and outputs complete and that all connectors are seated correctly, and all screw terminals are tightened.

! CAUTION: Risk of damage!

*Test the power supply to ensure it is "24 V DC ± 10 %" before wiring to the board.
Failure to test the suitability of the power supply BEFORE first power on can result in irreversible product damage that is NOT covered by warranty.*

7.2 Switching ON the Device

When the device is initially powered ON:

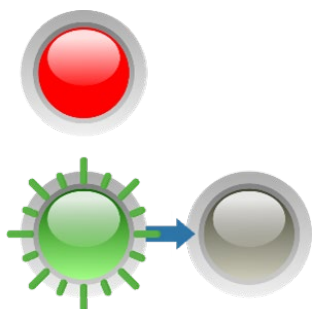

The Red LED illuminates solid to indicate power is being supplied to the interface.

The Green LED blinks rapidly then goes OFF to indicate that the microprocessor is operational.

NOTE: LEDs are only visible when the lid is removed from the transmitter housing.

NOTE: If a fault is detected, an error is displayed (RS232 variant), or the analog output will remain at 4 mA or 0 V.

Refer to [Error Conditions](#) contained in this document.

If the error condition persists, switch the device OFF and contact uk.sst.sales@processsensing.com

7.3 First Time Calibration

Calibration, or re-referencing, is required when the product is powered ON in the process application for the first time.

Refer to [Calibrating](#) contained in this document.

8 System Configuration

The OXY-FLEX Series of transmitters can be configured to output measuring ranges of 0.1...25 % O₂ and 0.1...100 % O₂; the entire measurement range is linear in both cases.

NOTE: Factory default is 0...25 % O₂ with linear 4...20 mA and 0...10 V DC outputs.

When configured for 0...100 % O₂, the analog output ranges can be customized to suit the application. Refer to [Setting the Calibration Type and Measurement Range](#) contained in this document.

The outputs can be configured to either 4...20 mA and 0...10 V DC or RS232. Refer to [Setting the Output Type](#) contained in this document.

NOTE: All outputs are referenced to the system GND.

A digital 3.3 V DC logic output cycles at the same frequency as the electrochemical pumping action of the oxygen sensing cell during normal operation, thus providing a real-time sensor health check. If the output ceases to cycle, the sensor has entered a startup or error state. This provides fault-proof operation.

NOTE: The digital output is also used during the calibration process to indicate the interface status.

A Green onboard LED mirrors the CYCLE output and can be used to visually determine the sensor status or during the calibration process.

A Red LED indicates the unit has power applied.

8.1 Setting the Output Type

The interface board is fitted with two jumper links which set the calibration type (Manual or Automatic) and oxygen measurement range (100 % or 25 %).

These settings may be configured at any time by adjusting the position of the header pin jumper links on the board.



WARNING: Danger of Death

*The equipment **MUST** be powered OFF.*

The jumper links must always be repositioned correctly and in the correct orientation.

1. Using a suitable screwdriver, remove the four screws and lid from the transmitter housing.
2. Using thin-nosed pliers, remove and replace the jumper links to the desired positions:
 - **RS232**; RS232 Rx and RS232 Tx
 - **Analogue output**; 0...10 V DC and 4...20 mA

NOTE: When selecting the output, you must choose either 0...10 V DC and 4...20 mA or RS232 Tx and RS232 Rx.

NOTE: Ensure jumper links are correctly seated and in the correct orientation, as shown in the output jumper link configuration.

3. When the configuration is complete, replace the four screws and the lid: secure to the transmitter housing using a suitable screwdriver.

Output Jumper Link Configuration

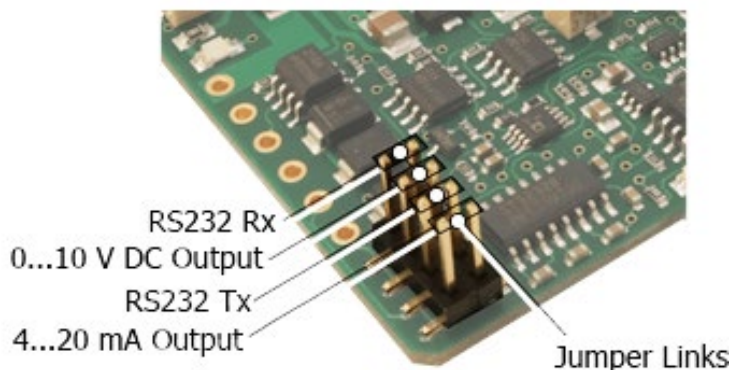

8.2 Setting the Calibration Type and Measurement Range

The interface board is fitted with two jumper links which set the calibration type (Manual or Automatic) and oxygen measurement range (100 % or 25 %).

These settings may be configured at any time by adjusting the position of the header pin jumper links on the board.



WARNING: Danger of Death

The equipment MUST be powered OFF.

The jumper links MUST always be repositioned correctly and in the correct orientation.

1. Using a suitable screwdriver, remove the four screws and lid from the transmitter housing.
2. Using thin-nosed pliers, remove and replace the jumper links to the desired positions:
 - Calibration type; Manual (MANUAL CAL) or Automatic (AUTO CAL)
 - Measuring range; 0.1...25 % O₂ or 0.1...100% O₂

NOTE: Ensure jumper links are correctly seated and in the correct orientation as shown in [Setting the Output Type](#) contained in this document.

3. When the configuration is complete, replace the four screws and the lid: secure to the transmitter housing using a suitable screwdriver.

Calibration and Measurement Range

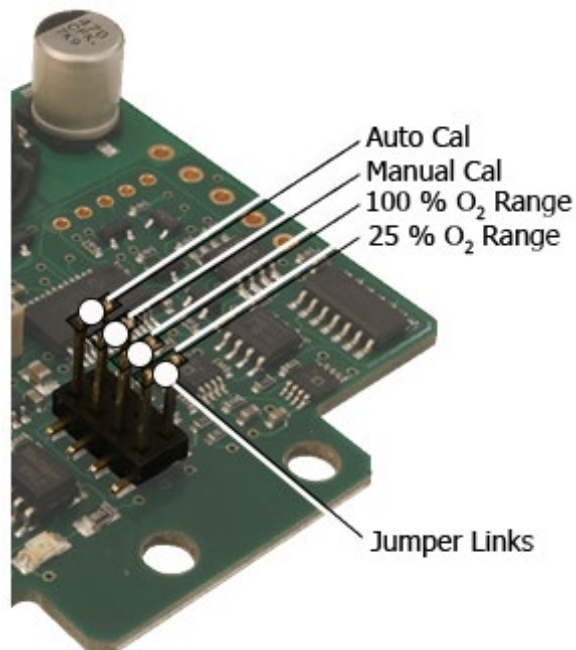

8.3 Digital Variant – RS232 Output

NOTE: When connecting the OXY-FLEX Series of transmitters using the RS232 connections, ensure *Tx* goes to *Rx* of the PC and *Rx* goes to *Tx* of the PC.

The OXY-FLEX Series of transmitters communicates via standard COM port settings that are default settings on most PCs and many other RS232 compatible devices.

If, however, communication problems are occurring, use the settings below to configure the PC or device COM Port:

- Baudrate: 9600
- Data bits: 8
- Parity: None
- Stop bits: 1
- Flow control: None

With the OXY-FLEX Series of transmitters RS232 outputs connected to a PC (or another RS232 compatible device), you can access two modes of operation: continuous data streaming and the menu screens.

The menu structure was created using VT100 terminal codes; refer to [Appendix A-Menu Structure](#) contained in this document for a full menu structure and example screens.

Recommended programs for communicating via PC serial RS232 are Tera Term, HyperTerminal (Windows default), or PuTTY.

The following sub-sections are based on Tera Term usage and instructions may vary if using another program.

When the OXY-FLEX Series of transmitters receives an <ENTER> keystroke from the connected PC or device, it automatically displays the `Menu Password` screen and stops streaming O₂ % and *Td* values.

When the correct password is entered, followed by the <ENTER> keystroke, the menu screens are accessed.

The menu screens are primarily for diagnostics and information, although there are user-configurable options that may be changed.

These are the automatic O₂ calibration %, the amount of output filtering (averaging), and the analog output ranges.

The menu security password may also be changed if required.

8.4 Menu Security Password

The password is factory set to “default.” This, however, may be changed to a user-specific password.

1. Connect the OXY-FLEX Series of transmitters via the RS232 interface to the PC.
2. Press <ENTER>; the *Menu Password* screen displays.
3. Input your current security password.
4. Press <ENTER> to access the *Menu* screens.
5. Type “2” to access the *Configuration* menu.
6. Type “3” to access the *Password Menu* screen.
7. Input your new security password.

NOTE: Password is case sensitive and has a maximum of 15 characters.

8. Press <ENTER> to save.

NOTE: The new password is now stored in memory and is retained on power loss.

NOTE: Pressing <ESC> returns the screen to the previous menu.

8.5 Automatic Calibration Value

The system is factory set to automatically calibrate to 20.7 % O₂ to allow simple calibration in the fresh air.

The auto-calibration value is factory set to 20.7 % to take into account average humidity in the atmosphere.

If a calibration with a gas of a different known O₂ concentration is required, the factory set value may be changed via the RS232 interface.

1. Connect the OXY-FLEX Series of transmitters via the RS232 interface to the PC.
2. Press <ENTER>; the *Menu Password* screen displays.
3. Input your security password.
4. Press <ENTER> to access the *Menu* screens.
5. Type “2” to access the *Configuration* menu.
6. Type “1” to access the *Enter Auto Calib* screen.
7. Input the oxygen concentration (%) of the calibration gas as a number to two decimal places.
8. Press <ENTER> to save.

NOTE: The new automatic calibration value is now stored in memory and is retained on power loss.

NOTE: If calibration is required with a different gas of known O₂ concentration and access to the RS232 menus via a PC is not available, a manual calibration must be performed.

Refer to [Manual Calibration](#) contained in this document.

8.6 Variable Output Filtering (T_d Averaging)

The OXY-FLEX Series of transmitters are factory default to use adaptive output filtering to give an optimum balance between output stability and response to oxygen changes.

This balance may be altered to suit the needs of your application.

1. Connect the OXY-FLEX Series of transmitters via the RS232 interface to the PC.
2. Press <ENTER>; the *Menu Password* screen displays.

3. Input your security password.
4. Press <ENTER> to access the *Menu screens*.
5. Type "2" to access the *Configuration* menu.
6. Type "2" to access the *Enter td Averaging* screen.
7. Input the required number, between 0 and 200; 0 for adaptive filtering (recommended), 1 for very fast and dynamic output response but relatively unstable to 200 for an extremely stable output but very slow response to oxygen changes.
8. Press <ENTER> to save.

NOTE: The new averaging value is now stored in memory and is retained on power loss.

8.7 Analog Output Minimum and Maximum Ranges

The OXY-FLEX Series of transmitters are factory default to output a range of 0.1...25 % O₂ via its two analog outputs.

This range can be expanded to 0.1...100 % O₂ by repositioning the jumper link as described in [Setting the Output Type](#) contained in this document.

When the unit is reconfigured to output 0.1...100 % O₂, the user also has the option to customize the output ranges via RS232 fully. This is extremely useful in applications where the O₂ variation is within a narrow band as it allows the analog outputs to be tailored to this limited range.

NOTE: The minimum and maximum range adjustment does NOT apply to the RS232 output and is overruled if the unit is reconfigured for 0.1...25 % O₂ operation.

Ensure the OXY-FLEX Series of transmitters are configured for 0.1...100 % O₂ operation; see [System Configuration](#) contained in this document.

1. Connect the OXY-FLEX via the RS232 interface to the PC.
2. Press < ENTER >; the *Menu Password* screen displays.
3. Input your security password.
4. Press <ENTER> to access the *Menu* screen.
5. Type "2" to access the *Configuration* menu.
6. Type "3" to access the *Enter O₂ Max Range* screen.
7. Input the required number between 1.00 and 100.00 to represent the maximum output range.

NOTE: The number must also be greater than the saved minimum range.

8. Press <ENTER> to save.
9. Press <ESC > to return to the *Configuration* menu.
10. Type "4" to access the *Enter O₂ Min Range* screen.
11. Input the required number between 0.00 and 99.00 to represent the minimum output range.

NOTE: The number must also be less than the saved maximum range.

12. Press <ENTER> to save.

NOTE: The new ranges are now stored in memory and are retained on power loss.

An example of changing the minimum and maximum output ranges would be in a fresh air atmosphere where the O₂ range is between 20...21 %.

The user could set the minimum output range to 19 % and the maximum output range to 22 %, and the outputs would vary linearly between.

The minimum and maximum ranges lock out the outputs at the set limits, so 19 % O₂ or lower would set the analog outputs to 0 V DC / 4 mA, and 22 % O₂ or higher would set the analog outputs to 10 V DC / 20 mA.

8.8 Analog Variants

Table 0...10 V DC and 4...20 mA Output Values

O ₂ %	Output Values			
	0...10 V DC output		4...20 mA output	
	0.1 ...25 % O ₂	0.1...100 % O ₂	0.1...25 % O ₂	0.1...100 % O ₂
20.7 %	8.28 V DC	2.07 V DC	17.25 mA	7.34 mA
100 %	-	10 V DC	-	20 mA
90 %	-	9.0 V DC	-	18.4 mA
25 %	10 V DC	2.5 V DC	20 mA	8 mA
5 %	2.0 V DC	0.5 V DC	7.2 mA	4.8 mA
0.01% (see Note)	0.04 V DC	0.01 V DC	4.06 mA	4.02 mA

NOTE: The analog output ranges represent 0.1...25% or 0.1...100% O₂ however, as PST's oxygen sensors cannot measure below 0.1 % O₂, this value is displayed as the range minimum.

9 Operation

9.1 Operating Tips

It is important that the attached oxygen sensor is installed and maintained correctly to ensure the best performance from your equipment.

9.2 RS232 Operation

With the OXY-FLEX Series of transmitters RS232 outputs connected to a PC (or any other RS232 compatible device), you can access two modes of operation: continuous data streaming and the menu screens.

Refer to [Digital Variant - RS232 Output](#) contained in this document.
Refer also to [Appendix A- Menu Structure](#) contained in this document.

9.3 Continuous Data Streaming

On power-up, after the initial 60s heater delay, the OXY-FLEX Series of transmitters will automatically begin outputting the measured O₂ concentration and sensor t_d as both are an averaged and raw value.

The averaged values give a stable output with the amount of averaging user variable, whilst the raw un-averaged values allow the user to detect sudden oxygen changes.

The averaged value is the measurement output on both the 4...20 mA and 0 ...10 V DC outputs. The sensor t_d value is the measure of the partial pressure of oxygen in the measurement gas. The O₂ concentration (%) is the t_d value scaled by the stored calibration value.

To stop or restart the data streaming:

1. Connect the OXY-FLEX Series of transmitters via the RS232 interface to the PC.
2. Type "S" (not case sensitive).

NOTE: Data streaming automatically ceases during calibration.

9.4 Menu Screens

The menu screens are primarily for diagnostics and information, although there are user-configurable options that may be changed.

Refer to [Digital Variant - RS232 Output](#) contained in this document.

To access the menu structure:

1. Connect the OXY-FLEX Series of transmitters via the RS232 interface to the PC.
2. Press < ENTER >; the *Menu Password* screen display

NOTE: The OXY-FLEX stops outputting O₂% and *t_d* values.

Input your security password.

Press <ENTER> to access the *Menu* screens.

10 Maintenance



WARNING: Danger of Explosion

Read the [Safety Instructions](#) before performing any type of maintenance on the equipment.

The attached oxygen sensor is heated to over 700 °C/1300 °F and is a source of ignition.

Ensure the sensor is cool before attempting to touch the equipment.

10.1 Calibrating

Our range of oxygen sensors do not directly measure the oxygen concentration but instead measures the partial pressure of oxygen within the measurement gas.

In order to output an oxygen concentration (%), the sensor must be calibrated, or more specifically, re-referenced in a known gas concentration, typically fresh air.

Regular calibration removes the effects of application and atmospheric pressure changes and also eliminates any sensor drift that may occur during the first few hundred hours of operation.

Calibration, or re-referencing, is achieved by connecting the calibration input to GND and monitoring the status of the digital cycle output or by visually monitoring the onboard green LED.

During the calibration process, the output will either automatically calibrate to a fixed reference or can be manually calibrated to any output by way of a PCB-mounted potentiometer.

NOTE: The fixed reference is factory set to 20.7 % O₂ for calibration in the fresh air; however, this value may be altered for calibration with a reference gas of any known oxygen concentration. Any new calibration value will be stored on power loss.

The auto or manual calibrate function is user-configurable; refer to [Setting the Calibration Type and Measurement Range](#) contained in this document.

Output Variant	Recommended Calibration Points / Recommended Calibration Gas
0.1...25 % O ₂	20.7 % O ₂ / Fresh air
0.1...100 % O ₂	100 % O ₂ / Pure oxygen

10.2 Automatic Calibration

Ensure the OXY-FLEX Series of transmitters are configured for automatic calibration. Refer to [Setting the Calibration Type and Measurement Range](#) contained in this document.

1. Place the sensor probe in the calibration gas, typically fresh air.
2. Allow the output to stabilize for at least 5 minutes (10 minutes if powering from cold). Referring to [Electrical Connections](#) contained in this document, apply GND to the CALIBRATE input (pin 3) for a minimum of 12 seconds. During the 12 seconds, the CYCLE output (pin 4) and the Green LED will go high/ON, blink rapidly, go high/ON, go low/OFF, then return to cycling normally to indicate normal operation has resumed. At this point, remove GND from pin 3.

NOTE: The output will now track to the correct value for the calibration gas *

3. Calibration is complete.

NOTE: New calibration values are stored in memory and retained on power loss.

10.3 Manual Calibration

1. Ensure the OXY-FLEX Series of transmitters are configured for manual calibration. Refer to [Setting the Calibration Type and Measurement Range](#) contained in this document.
2. Place the sensor probe in the calibration gas, typically fresh air.
3. Allow the output to stabilize for at least five minutes (10 minutes if powering from cold).
4. Referring to [Electrical Connections](#) contained in this document, apply GND to the CALIBRATE input (pin 3) for a minimum of five seconds or until the CYCLE output and Green LED blink at a steady 1 Hz. Remove GND from pin 3. Manual Calibration is now initialized.
5. Referring to [Setting the Calibration Type and Measurement Range](#) contained in this document, adjust the MANUAL CAL POT until the output equals the correct value of the calibration gas concentration.
6. Re-apply GND to pin 3 for a minimum of five seconds. During the five seconds, the CYCLE output/LED will blink rapidly, go high/on, go low/off, then return to cycling normally to indicate normal operation has resumed. At this point, remove GND from pin 3.

NOTE: The output will now track to the correct value for the calibration gas *
Calibration is complete.

NOTE: New calibration values are stored in memory and retained on power loss.

* If calibrating in the fresh air, the output value (RS232/Voltage/Current) given equates to 20.7 % oxygen with an error of ± 0.2 %. After calibration in the fresh air, the voltage output should read 8.28 V. The current output should read 17.25 mA, and the RS232 will stream a five-character ASCII code representing the O₂ %.

10.4 Error Conditions

If the oxygen sensor is incorrectly connected or is damaged, the OXY-FLEX Series of transmitters will highlight this by blinking the CYCLE output (pin 4) and Green LED in *three short blinks – 1 long blink* pattern or continuously OFF.

In addition, an error code displays on the RS232 output, and the analog outputs will default to 4 mA and 0 V.

If an error condition occurs, the equipment must be powered down and all wiring checked before re-applying the power.

If the error condition remains, contact uk.sst.sales@processsensing.com for guidance.

10.5 Cleaning

Clean the outer surfaces of the housing regularly with non-abrasive materials to prevent a buildup of contaminants.

Isopropyl alcohol (IPA) and a lint-free cloth are recommended.



CAUTION: Risk of damage!

Never use chemical cleaning agents or high-pressure water or steam to clean the equipment.

10.6 Disposal

The OXY-FLEX Series of transmitters must be disposed of as electrical waste.

Please observe your local and national regulations.

11 Appendix A – Menu Structure

Password Screen

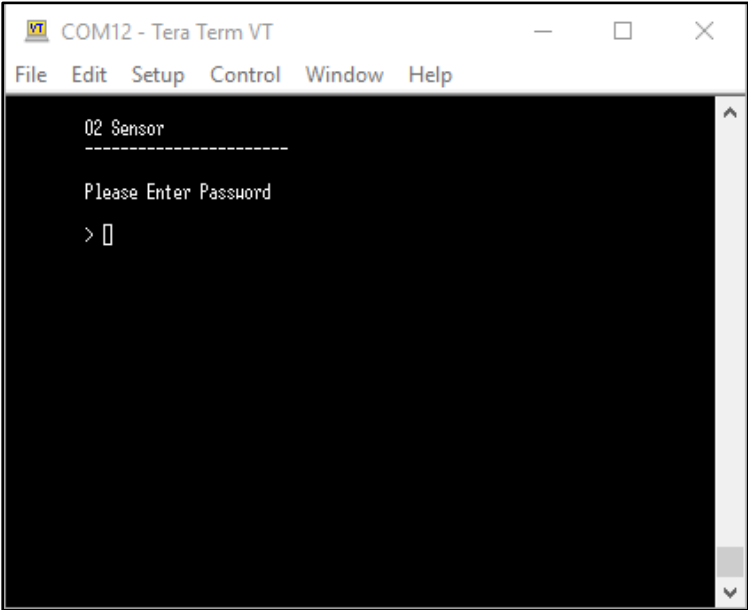

Main Menu

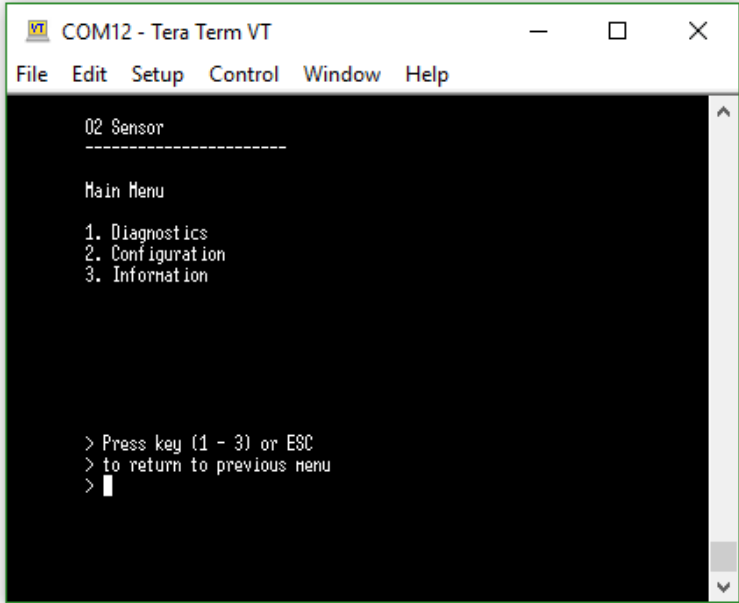

Diagnostics Screens

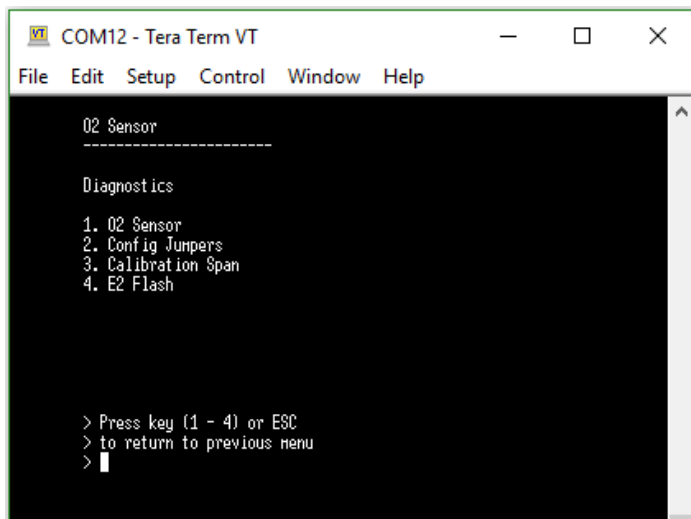

Diagnostics Main Menu

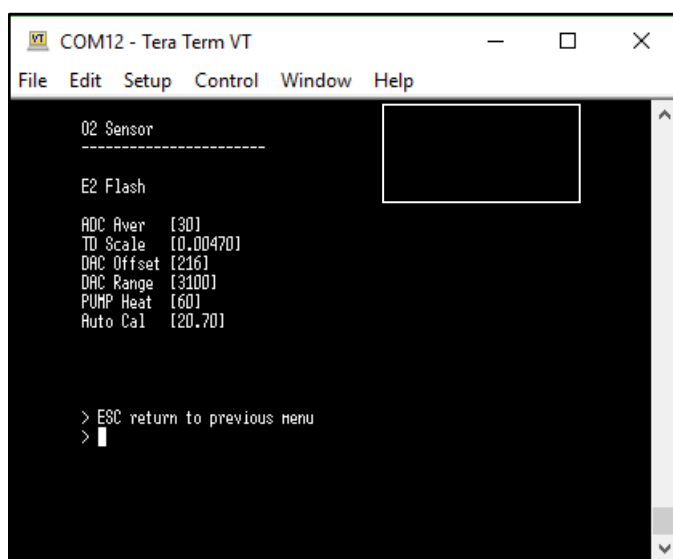
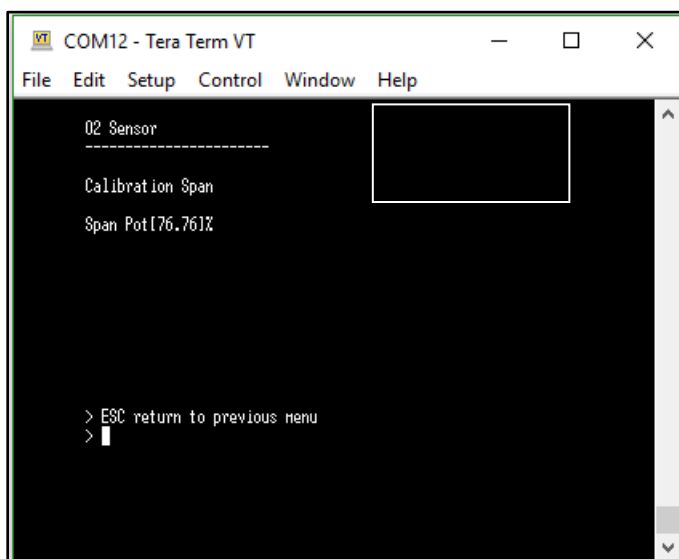
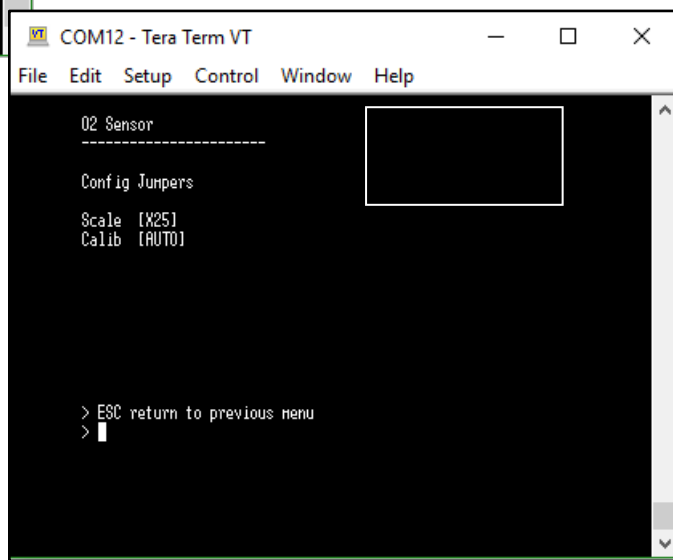
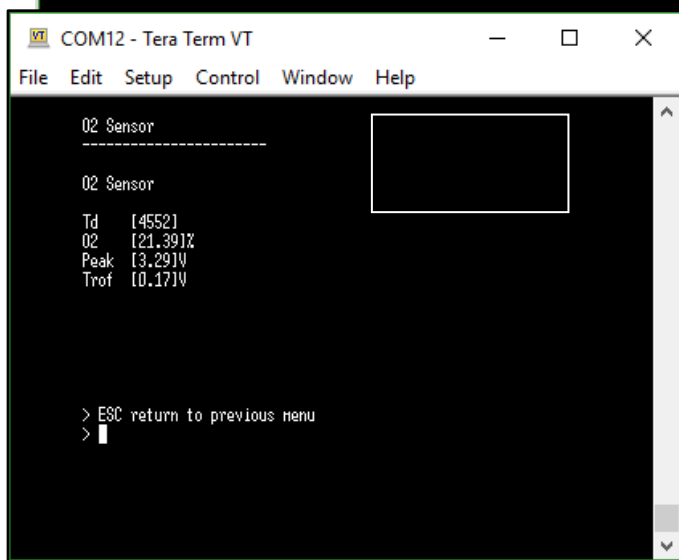

Configuration Screens

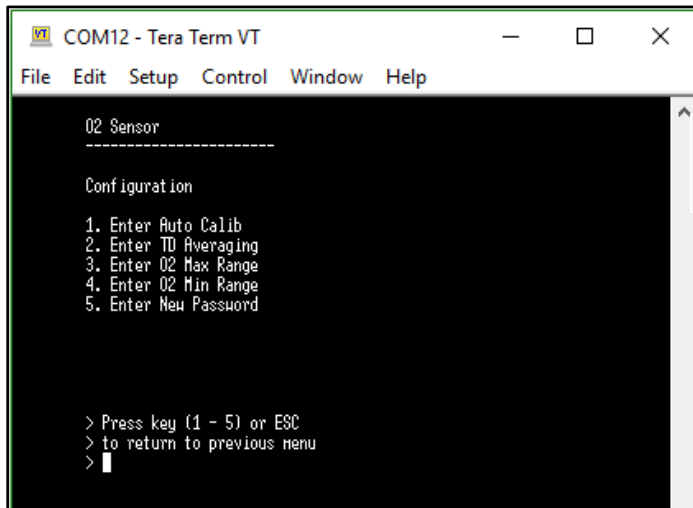

Configuration Main Menu

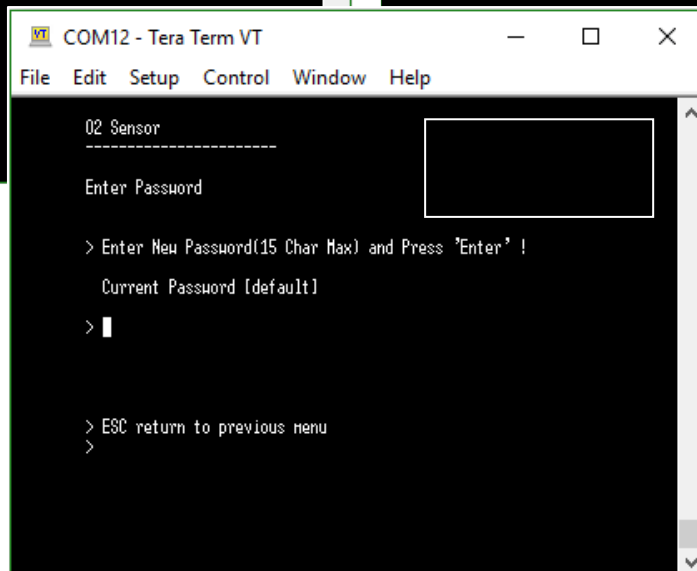
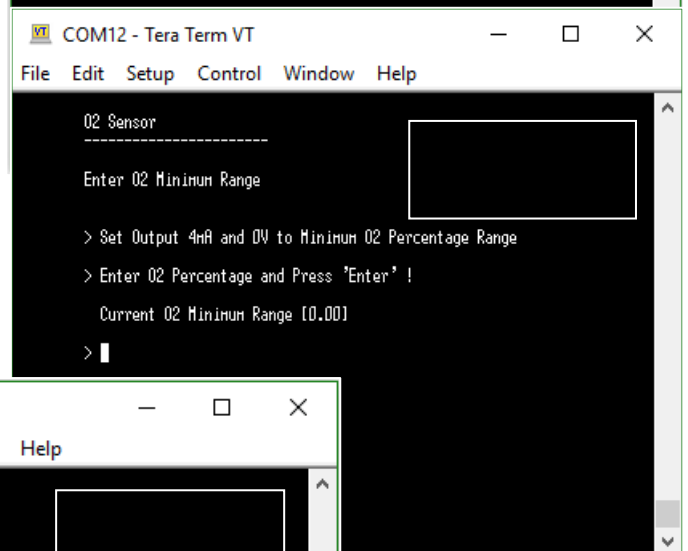
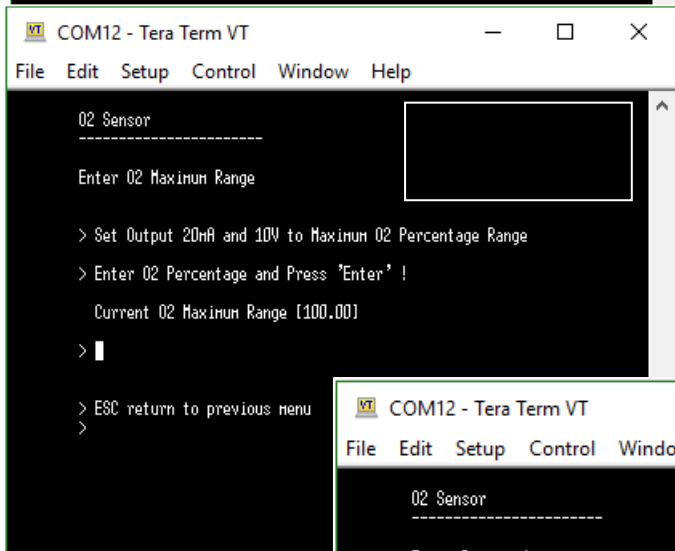
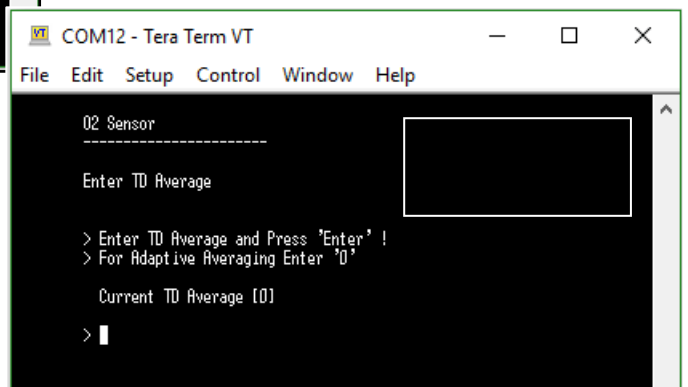
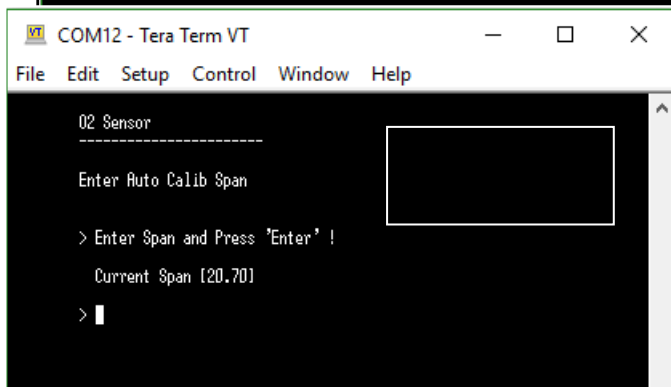

Information Screens

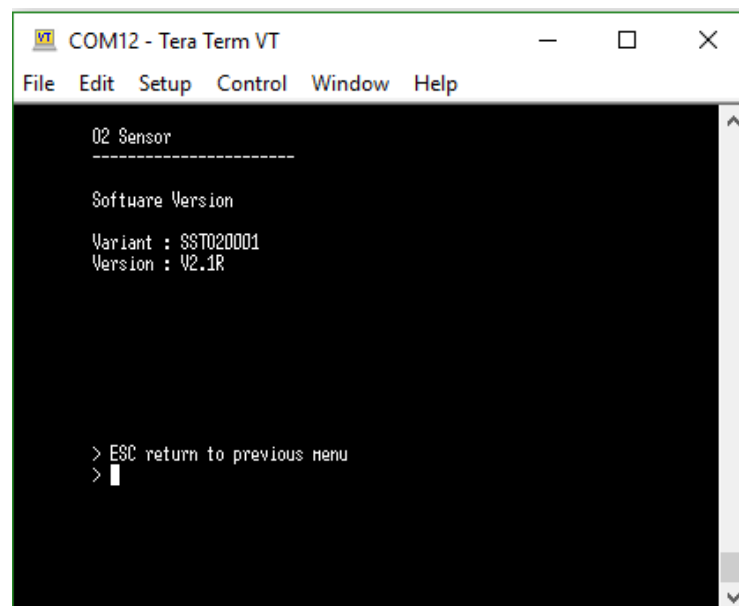
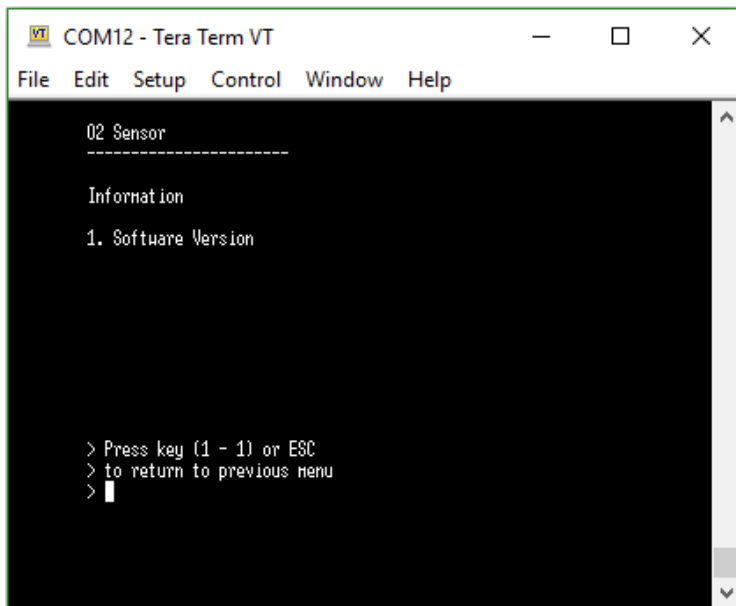

12 Appendix B – Quality, Recycling & Warranty Information

The PST Oxygen group of companies, Aii, Ntron, and SST comply with applicable national and international standards and directives.

Full information can be found on our website at: [O2 Compliance Documents \(processsensing.com\)](https://processsensing.com)

The compliance site contains information on the following directives:

- ATEX (Equipment for explosive atmospheres)
- REACH (Registration, Evaluation, Authorisation, and Restriction of Chemicals)
- RoHS (Restriction of hazardous substances in electrical and electronic equipment)
- ETL (The ETL Mark is proof of product compliance to North American safety standards)
- WEEE (Waste electrical and electronic equipment recycling)
- Recycling Policy
- Warranty & Returns



www.ProcessSensing.com

© 2022 Process Sensing Technologies
